

**HITACHI**

**AIR CONDITIONING FEE**

2016/2017



**HITACHI**

# AIR CONDITIONING CATALOGUE 2017

RESIDENTIAL UNITS

HEATING AND DHW

INDOOR UNITS

COMMERCIAL

VRF SYSTEMS

AIR RENEWAL

Feel the Next >



Feel the Next

# RESIDENTIAL

## AIR CONDITIONING FOR THE HOME

### 1x1 SETS



**WALL-MOUNTED PREMIUM PSC**

Cooling: 1.80~3.50 kW  
Heating: 2.30~4.00 kW

**AKEBONO RXB**

Cooling: 2.50~5.00 kW  
Heating: 3.20~5.80 kW

**PERFORMANCE RPC**

Cooling: 2.00~7.00 kW  
Heating: 2.50~8.00 kW

**ENTRY PEC**

Cooling: 2.00~5.00 kW  
Heating: 2.50~6.00 kW

**ENTRY R32 PED**

Cooling: 2.00~5.00 kW  
Heating: 2.50~6.00 kW

21

23

25

27

29



**FLOOR**

**AKEBONO RXB**

Cooling: 2.50~5.00 kW  
Heating: 3.40~6.00 kW

**PERFORMANCE RPA**

Cooling: 2.50~5.00 kW  
Heating: 3.40~6.00 kW

31

33



**DUCT**

**MONODUCT RAD RPA**

Cooling: 2.50~7.10 kW  
Heating: 3.50~8.00 kW

35



**CASSETTE**

**CASSETTE RAI RPA**

Cooling: 2.50~5.00 kW  
Heating: 3.50~6.20 kW

37

## MULTIZONE

## MULTIZONE AIR CONDITIONING, IDEAL FOR THE HOME AND SMALL BUSINESSES

### OUTDOOR UNITS

### INDOOR UNITS



**RAM-33NP2B~53NP2B**

Up to 2 indoor units

**RAM-53NP3B~68NP3B**

Up to 3 indoor units

**RAM-70NP4B**

Up to 4 indoor units

**RAM-90NP5B**

Up to 5 indoor units

**RAM-110NP6B**

Up to 6 indoor units



**WALL-MOUNTED**

Cooling: 1.50~5.00 kW  
Heating: 1.50~6.00 kW

44



**FLOOR**

Cooling: 2.50~5.00 kW  
Heating: 3.40~6.00 kW

45



**DUCT**

Cooling: 1.80~5.00 kW  
Heating: 2.50~6.00 kW

47



**CASSETTE**

Cooling: 2.50~5.00 kW  
Heating: 3.50~6.20 kW

46

# HEATING

## IDEAL FOR RADIANT FLOOR HEATING AND BOILER REPLACEMENT



**YUTAKI S80**

79

4~6 HP, single-phase and three-phase  
▪ DHW up to 80°C  
▪ With or without tank (compatible with any tank on the market)



**YUTAKI S**

83

2~10 HP, single-phase and three-phase  
▪ New model 2.5 HP  
▪ Compact model



**YUTAKI S COMBI**

87

2~6 HP, single-phase and three-phase  
▪ New model 2.5 HP  
▪ Solar panel possibility  
▪ Plug & Play



**YUTAKI M**

91

3~6 HP, single-phase and three-phase  
▪ DHW up to 60°C  
▪ Reversible



**YUTAMPO**

93

▪ Uses renewable energy. Up to 70% free hot water



# INDOOR UNITS

96

CHOOSE THE INDOOR UNITS AND AIR-CONDITION ALL THE AREAS YOU NEED, WITH THE COMMERCIAL AND VRF SET FREE RANGES



## CASSETTE

99

Cooling: 1.70~14.00 kW  
Heating: 1.90~16.00 kW  
2-way  
4-way 600 x 600  
4-way 800 x 800  
▪ With sensor  
▪ Without sensor



## DUCT

103

Cooling: 1.70~28.00 kW  
Heating: 1.90~31.00 kW  
Mini hotel  
Low-silhouette  
Medium-pressure  
High-pressure



## WALL-MOUNTED

107

Cooling: 1.70~10.00 kW  
Heating: 1.90~12.50 kW  
▪ With valve  
▪ Without valve



## FLOOR

109

Cooling: 2.00~10.00 kW  
Heating: 2.00~12.50 kW  
▪ With Case  
▪ Without Case



## CEILING

111

Cooling: 2.00~10.00 kW  
Heating: 2.00~12.50 kW  
▪ With sensor  
▪ Without sensor

# COMMERCIAL

116

AIR CONDITIONING FOR SMALL AND MEDIUM BUSINESS/OFFICE



## UTOPIA IVX COMFORT

119

Cooling: 7.10~30.00 kW  
Heating: 8.00~33.50 kW  
▪ 4 different zones  
▪ Independent control of the indoor units



## UTOPIA ES

131

Cooling: 7.10~30.00 kW  
Heating: 8.00~33.50 kW  
▪ 4 different zones  
▪ Centralized control

# VRF SYSTEMS

140

AIR CONDITIONING FOR BUSINESSES/OFFICES WITH GREATER DEMANDS



## CENTRIFUGAL VRF

143

Cooling: 10.0~24.00 kW  
Heating: 11.20~25.00 kW  
▪ 6 different zones  
▪ Concealed in facade

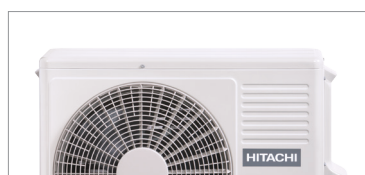

## UTOPIA IVX PREMIUM

153

Cooling: 5.00~30.00 kW  
Heating: 5.60~33.50 kW  
▪ 8 different zones  
▪ Independent control

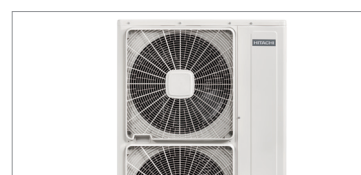

## MINI VRF

163

Cooling: 11.20~33.50 kW  
Heating: 12.50~37.50 kW  
▪ 12 different zones  
▪ Independent control



## VRF MODULAR

169

High and very high efficiency  
Cooling: 22.40~150.00 kW  
Heating: 25.00~165.00 kW  
▪ 64 different zones  
▪ Independent control

# AIR RENEWAL

180

IDEAL FOR IMPROVING THE ENERGY EFFICIENCY OF THE FACILITIES



**KPI 4E**  
Heat recovery  
Complies with regulation 1253/2014  
Three speeds



**183 ACTIVE KPI**  
Energy recovery  
Complies with regulation 1253/2014  
Three speeds



**185 ECONOFRESH 187**  
Air renewal  
Ideal for premises with **large thermal loads**  
Natural cooling

# CONTROLS AND ACCESSORIES

190

TOTAL MANAGEMENT AND CONTROL FOR ALL TYPES OF FACILITIES.  
INDIVIDUAL, CENTRALIZED AND MANAGEMENT SOFTWARE.



**RESIDENTIAL 193**



**HEATING 195**



**COMMERCIAL AND VRF SYSTEMS 199**



**MANAGEMENT AND CENTRALIZED CONTROL SYSTEMS 201**





Edificio Diamante, Andorra  
DHW HEATING



---

# WE ARE WHAT WE DO

---



**HITACHI**  
Air conditioning solutions

There was a change in 2015, Johnson Controls and Hitachi Air Conditioning united to enhance the competitive advantages of their air conditioning services, forming the largest company in the air conditioning sector, Johnson Controls Hitachi Air Conditioning Company (JCH). This union reinforces the trust in their customers to continue offering high quality products and services.

- Johnson Controls incorporates the automation of management and control systems.
- Hitachi offers its full range of air conditioning solutions. Products with the Hitachi I+D+i seal.

---

We look for stories from our customers in which our products play a fundamental role, stories about unforgettable moments during that endless dinner where the climate helps you enjoy the evening even more. Stories about never-ending afternoons of shopping in your favorite stores. Stories where, without knowing it, air conditioning influences customers' daily comfort and even their mood. Or simply stories about resting at your favorite corner where the world disappears.





**IF YOU WANT TO MOVE FAST  
GO BY YOURSELF.  
IF YOU WANT TO GO FAR...  
DO IT IN A GROUP.**

What is very clear is that thanks to the talent and dedication of our team, we have been able to develop air conditioning solutions that are flexible and adaptable to the requirements of all types of facilities, ranging from a big building to a business that's just starting in a small place. Also getting just the right temperature for enjoying life at home.



ONE SITUATION, ONE SOLUTION

## IF TECHNOLOGY IS THE ANSWER... WHAT IS THE QUESTION?



















There are many. There are as many questions as there are needs or situations. How do you air-condition a street level business? Is there a unit that allows you to save on your electric bill? How can you have different temperatures for each space?



# FIND THE SOLUTION

The **Quick Selection Guide** has all of the answers, all the HITACHI air conditioning solutions that fit the requirements of each facility.

We help you choose the HITACHI product according to the connectible indoor units, power, energy efficiency and economic proposal that guarantee the highest comfort.

DATA PER OUTDOOR UNIT*	 MULTIZONE	 UTOPIA ES	 UTOPIA IXV COMFORT	 CENTRIFUGAL VRF	 UTOPIA IXV PREMIUM	 SET FREE MINI	 SET FREE SIDE FLOW	 SET FREE Modular High Seasonal Performance	 SET FREE Modular Very High Seasonal Performance
Maximum number of connectible indoor units	up to 6	up to 4	up to 4	up to 6	up to 8	up to 12	up to 10	up to 64	up to 64
Maximum cooling capacity	up to 17600 W	up to 25000 W	up to 30000 W	up to 24000 W	up to 30000 W	up to 15500 W	up to 33500 W	up to 150000 W	up to 100000 W
Maximum cooling distance (real)	up to 25 m	up to 50 m	up to 100 m	up to 100 m	up to 100 m	up to 75 m	up to 100 m	up to 165 m	up to 165 m
Maximum cooling distance (equivalent length)	up to 25 m	up to 70 m	up to 125 m	up to 125 m	up to 125 m	up to 90 m	up to 125 m	up to 190 m	up to 190 m
Fan type	AXIAL horizontal discharge	AXIAL horizontal discharge	AXIAL horizontal discharge	AXIAL conductive discharge	AXIAL horizontal discharge	AXIAL horizontal discharge	AXIAL horizontal discharge	AXIAL vertical discharge	AXIAL vertical discharge
Available static pressure	NO	NO	NO	100 Pa~120 Pa	NO	NO	NO	up to 50 Pa	up to 50 Pa
Independent control of the indoor units	YES	NO	YES	YES	YES	YES	YES	YES	YES
Centralized control	Optional (with PSC-6RAD interface)	YES (bus H-LINK)	YES (bus H-LINK)	YES (bus H-LINK)	YES (bus H-LINK)	YES (bus H-LINK)	YES (bus H-LINK)	YES (bus H-LINK)	YES (bus H-LINK)
Energy efficiency level									
Price level	★	★★	★★★	★★★★★	★★★★★	★★★★★	★★★★★	★★★★★	★★★★★



**CHOOSE THE INDOOR UNITS THAT BEST FIT THE DECORATION AND NEEDS OF THE FACILITY**

## EUROVENT CERTIFICATION, A STEP IN PRODUCT SELECTION

Eurovent certified air conditioning solutions give you the confidence to install Hitachi equipment in all types of applications. This certification guarantees the performance of the equipment under demanding conditions in compliance with European legislation. In this way, prescribers, installers and end users have all the guarantees of quality.

Being in the directory of products certified by Eurovent means being a manufacturer that offers transparency and efficiency to the entire business chain.

Remember to request the Eurovent certificate for your equipment.

**WHEN THINGS  
ARE CLEAR,  
MAKING  
DECISIONS  
IS EASIER**



## DIGITAL TOOLS FOR GENERATING DIGITAL CLIENTS

### HI -QUOTE APP FOR INSTALLERS



#### **It works for you.**

Automate visits to your clients; this app WORKS FOR YOU, because you can schedule and control all your visits, make the budget for your client's air conditioning project on the spot, including your list of materials and Hitachi equipment and show your client how the equipment will look when it is installed in their house or business in 3D reality.

For more information, visit: [www.hi-quote.com](http://www.hi-quote.com)

### ERROR CODE APP



Free mobile app for technical services

It saves time and correctly identifies errors in a few steps. Enter the model, power and type of product, and a screen will automatically appear with the error codes and their meaning.

### HI-KUMO APP. TURN ON, TURN OFF AND OTHER FUNCTIONS FROM YOUR PHONE



#### **Are you away from home? Don't worry.**

You can adjust the temperature, program the week, activate vacation mode and perform countless other functions from your mobile device.

Turn your unit on and off, wherever you are.







# RE SI DEN TIAL





# 1X1 AIR/AIR

## HEAT PUMPS

<b>HEAT PUMPS</b>	<b>21</b>
<hr/>	
WALL-MOUNTED	
<hr/>	
PREMIUM PSC	21
<hr/>	
AKEBONO RXB	23
<hr/>	
PERFORMANCE RPC	25
<hr/>	
ENTRY PEC	27
<hr/>	
ENTRY PED	29
<hr/>	
FLOOR	
<hr/>	
AKEBONO F RXB	31
<hr/>	
PERFORMANCE RPA	33
<hr/>	
DUCT	
<hr/>	
MONODUCT RAD RPA	35
<hr/>	
CASSETTE	
<hr/>	
CASSETTE RAI RPA	37

RESIDENTIAL / 1x1 SETS

# AN AIR CONDITIONING UNIT FOR YOUR WHOLE LIFE

Because all your clients are different and seek personalized air conditioning solutions.

- Comfort, well-being and savings for your clients.
- Ease and comfort in your installation.

Resting with the suitable temperature facilitates optimum performance throughout the day.

Good air conditioning helps you spend more time at home, enjoying moments with friends and family.

The residential range of products is the ideal solution created for each home.

Additionally, it helps in reducing energy consumption as it is energy class A+++ and displays the kW in its Eco-Control.

## CONTROL OPTIONS



SPX-WKT2 WIRED  
CONTROL



WIRELESS ECO  
CONTROL

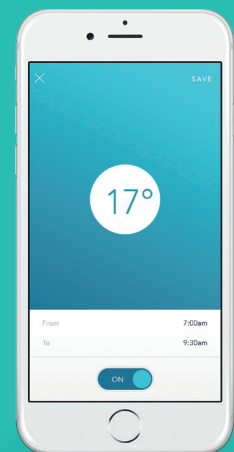

HI-KUMO APPLICATION

THE ACTIVE CARBON-BASE AC FILTERS  
**REDUCE BACTERIA  
AND ODORS**

INDOOR UNITS  
**COMPATIBLE  
WITH MULTIZONE  
OUTDOOR UNITS**  
*\*depending on model*



GREATER COMFORT WITH THE **ECO SENSOR**, WHICH ADJUSTS THE EQUIPMENT OPERATION TO THE ACTIVITY IN THE ROOM  
*\*depending on model*



HIGH POWER DUE TO **HITACHI'S OWN  
COMPRESSORS**



## HI-KUMO APP

The application for programming and controlling air conditioning from any mobile device, Smartphone or Tablet.



With this application you can turn the air conditioning unit on or off before arriving home or even check if it has been left running and turn it off right then.



### WHAT IS NEEDED? 3 KEY STEPS

1. Connect the SPX- WFG01 Wi-Fi adapter to the air conditioning unit.
2. Download Hi-Kumo from Google Play or the AppStore.
3. Configure the mobile device and air conditioning unit connection.

**Ready! The air conditioning is ready to be programmed from the mobile device.**



**COMPATIBLE WITH:**  
**Wall mounted**  
 Premium RAK-18-35PSC  
 Akebono RAK-25-50RXB / RAK-18QXB  
 Performance RAK-18-50RPC / RAK-15QPC

**Floor**  
 Akebono F RXB  
 Cassette RAI-25-50QPB  
 Ducts RAD-18-50QPB

 **Google Play**

 **App Store**

## NEW WIRED CONTROL SPX-WKT2



The remote control that controls up to 13 indoor units with weekly programming.

Easy to install, the maximum distance between the indoor unit and the control is 15 m.

You can choose where to place the temperature sensor: on the indoor unit, on the control, or both.

### MAIN FUNCTIONS

- Fan speed control
- Adjust the direction of the slats, horizontal or vertical
- Vacation Mode (Leave Home)
- Sleep, can be programmed for 1, 2, 3 or 7 hours
- Mode: automatic, program, Eco
- Silent

#### COMPATIBLE WITH:

##### Wall mounted

Premium RAK-18-35PSC  
Akebono RAK-25-50RXB / RAK-18QXB  
Performance RAK-18-50RPC / RAK-15QPC

##### Floor

Akebono F RXB  
Cassette RAI-25-50QPB  
Ducts RAD-18-50QPB

## ECO CONTROL

**THE CONTROL THAT SHOWS THE AIR CONDITIONING CONSUMPTION IN THE CURRENT AND PREVIOUS MONTH.**

With this function you will know how many kW the unit consumes, and you can identify them in the electric bill.

### CUSTOMIZED LIFESTYLE PROFILES.

- Allows the unit to start or stop its operation according to the needs of the consumer, with various programming options.

- The Leave Home mode lets you come home to your desired temperature after a month of rest.

- The Sleep mode causes the unit to set the optimum temperature and then automatically turn off to avoid non-necessary consumption.



### MAIN FUNCTIONS

- Control fan speed
- Automatic mode or program
- Eco Mode
- Silent Mode
- Sleep
- Leave Home
- Powerful that allows the air conditioning unit to warm / cool faster
- History shows the errors unit may have and saves a history of them
- Defrost

**WALL MOUNTED**  
DC INVERTER HEAT PUMPS

**PREMIUM PSC**  
RAK-18~35PSC

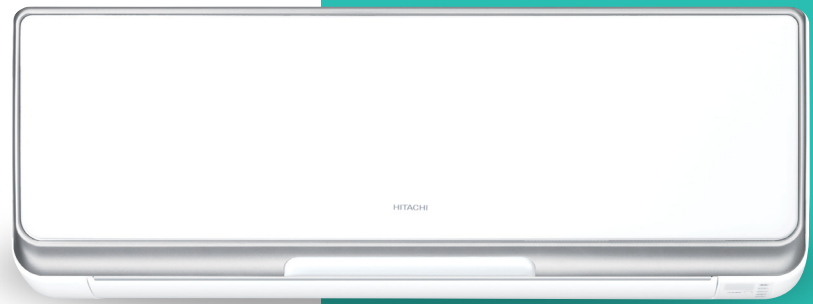

**CHARACTERISTICS**

**Eco-Control**

Savings on your energy bill, showing the unit's real consumption on its screen, both for the current and previous month.

**Eco Sensor**

Sensor that automatically adjusts the equipment operation to the activity in the room, allowing for greater energy savings.

**Energy class A+++\***

Other control options:  
**H-Link Adapter.**

**New wired control SPX-WKT2**

Weekly programming of up to 13 indoor units using a single remote control. It also allows you to choose where to place the temperature sensor.

**Stainless Plasma Air Purification with Self-cleaning Robot**

Clean air and no bad odors thanks to the negative that prevent the accumulation of bacteria and purifies the air in the room.

*An air conditioning unit for life  
thanks to its stainless steel interior,  
Stainless Plasma Air Purification.*

\*Depending on model.





## PREMIUM PSC

NAME OF THE SET			PREMIUM 18 PSC	PREMIUM 25 PSC	PREMIUM 35 PSC
INDOOR UNITS			RAK-18PSC	RAK-25PSC	RAK-35PSC
Nominal power (min-max) <sup>(1)</sup>	Cooling	kW	1.80 (0.50-2.80)	2.50 (0.50-3.40)	3.50 (0.50-4.10)
	Heating	kW	2.30 (0.60-4.80)	3.20 (0.60-5.80)	4.00 (0.60-6.60)
Sound pressure level (very low - low - medium - high) <sup>(2)</sup>	Cooling	dB(A)	22 - 28 - 34 - 40	22 - 28 - 34 - 42	23 - 28 - 34 - 44
	Heating	dB(A)	22 - 30 - 34 - 41	22 - 30 - 34 - 42	23 - 30 - 34 - 44
Sound power (Eurovent data)		dB(A)	54	56	58
Airflow (very low - low - medium - high)	Cooling	m³/h	260 - 300 - 420 - 470	260 - 320 - 420 - 510	270 - 320 - 420 - 520
	Heating	m³/h	260 - 300 - 420 - 540	260 - 370 - 520 - 600	270 - 410 - 520 - 610
Pipe diameter (Liquid - Gas)		inches	1/4 - 1/2	1/4 - 1/2	1/4 - 1/2
Condensate Evacuation Diameter		mm	16	16	16
Remote control (standard)			Eco Control	Eco Control	Eco Control
OUTDOOR UNITS			RAC-18WSC	RAC-25WSC	RAC-35WSC
Absorbed nominal power (min-max)	Cooling	kW	0.30 (0.07-0.88)	0.47 (0.07-0.96)	0.81 (0.07-1.35)
	Heating	kW	0.37 (0.06-1.62)	0.57 (0.06-2.25)	0.79 (0.06-2.45)
EER - COP			6.00 - 6.13 (A/A)	5.32 - 5.61 (A/A)	4.35 - 5.06 (A/A)
SEER			7.41	8.50	8.50
SCOP (Average Climate Class)			4.60	4.68	4.72
Energy class <sup>(3)</sup>	Cooling		A ++	A +++	A +++
	Heating		A ++	A ++	A ++
Sound pressure level <sup>(4)</sup>	Cooling	dB(A)	46	48	49
	Heating	dB(A)	46	48	49
Airflow	Cooling	m³/h	1860	1860	1920
	Heating	m³/h	1620	1620	1620
Power supply			220-230 V, 1 Ph, 50 Hz	220-230 V, 1 Ph, 50 Hz	220-230 V, 1 Ph, 50 Hz
Pipe diameter (Liquid - Gas)		inches	1/4 - 1/2	1/4 - 1/2	1/4 - 1/2
Maximum length		m	20	20	20
Maximum height		m	10	10	10
Refrigerant charge		kg (m)	1.35 (20)	1.35 (20)	1.35 (20)
Refrigerant fluid			R410A	R410A	R410A
Compressor			DC Scroll	DC Scroll	DC Scroll
PRICE OF THE SET					

(1) The nominal power for cooling and heating is the combined power of the HITACHI standard split system and is based on the following conditions (ISO 5151):  
 - Cooling: indoor temperature 27°C DB, 19°C WB; outdoor temperature 35°C DB.  
 - Heating: indoor temperature 20°C DB; outdoor temperature 7°C DB, 6°C WB.  
 - Pipe length to 5 m; height at 0 m.  
 (2) The sound level measurement is performed in an anechoic camera 1 m from the discharge grille and 0.8 m below the center of the indoor unit.  
 (3) Data calculated in compliance with communication prEN14825 and 2012/c 172/01.  
 (4) The sound level measurement is performed in an anechoic camera at 1 m from the surface and at 1 m from the ground level.

Guaranteed performance

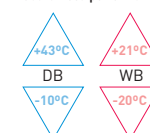

RAK-18~35PSC

12 kg



RAC-18~35WSC

40 kg

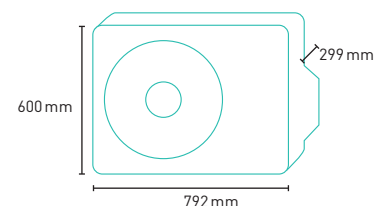

For more information about controls, see page 193.  
 Recommended prices - VAT not included, Waste Electrical and Electronic Equipment Directive (WEEE) fee not included.  
 To create the energy label visit our website [www.hitachiircon.es](http://www.hitachiircon.es) and use our Hitachi ErP Active Tool application.

## WALL MOUNTED DC INVERTER HEAT PUMPS

# AKEBONO RXB

RAK-25~50RXB

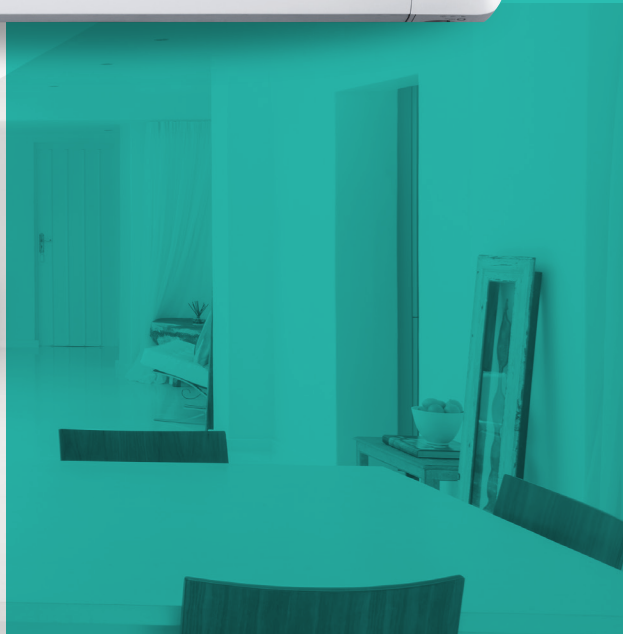
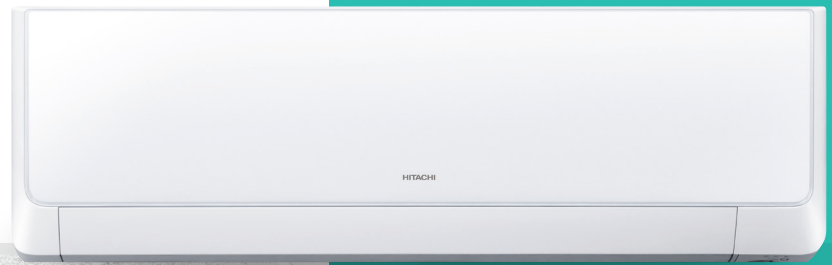

## CHARACTERISTICS

### Eco Control

Shows real consumption, creates custom programs that optimize the equipment operation.  
Standard wireless remote control.

### The active carbon-base special AC filter

works with a mix of silver-base antibacterial substances. It is sustainable because it respects the biocidal regulation, it is antiviral, antimicrobial and it has effect on a wide range of odiferous elements.

### Energy class A+++\*

### Nano Stainless Prefilter

Reduces dust build-up since it is stainless steel and easy to clean.

Other control options:  
**H-Link Adapter.**

### New wired control SPX-WKT2

With weekly programming, it allows you to choose where to place the temperature sensor and to centralize management of up to 13 indoor units. The maximum distance between the indoor unit and the control is 15 m.

### Presence Sensor

Energy conservation by automatic activation of the Eco Mode, when no human movement is detected, thus providing air conditioning without non-necessary consumption.

### Flexibility

Akebono RXB is compatible with all Multizone outdoor units, allowing the installation to be expanded according to your needs.

*Its functions make it ideal for rooms where people pass through intermittently. The presence sensor starts the operation when it detects human movement, and gradually decreases it when there is no one around, thus achieving a significant savings in electricity consumption.*

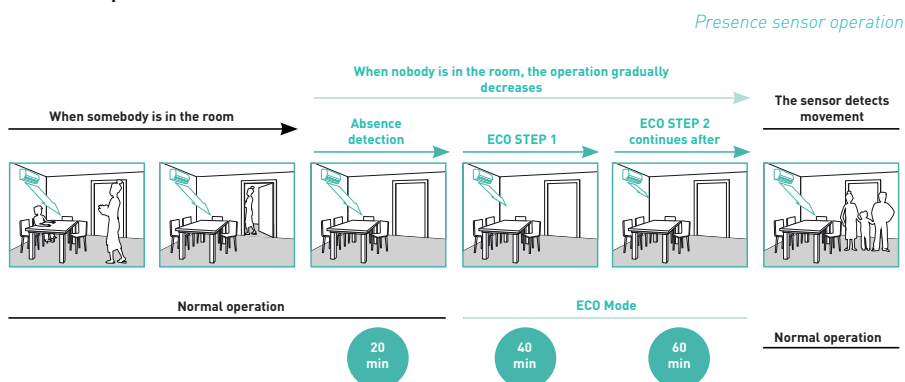

\*Depending on model.





## AKEBONO RXB

NAME OF THE SET			AKEBONO 25 RXB	AKEBONO 35 RXB	AKEBONO 50 RXB
INDOOR UNITS			RAK-25RXB	RAK-35RXB	RAK-50RXB
Nominal power (min-max) <sup>(1)</sup>	Cooling	kW	2.50 (0.90-3.10)	3.50 (0.90-4.00)	5.00 (1.90-5.20)
	Heating		3.20 (0.90-4.20)	4.00 (0.90-4.80)	5.80 (2.20-7.00)
Sound pressure level (very low - low - medium - high) <sup>(2)</sup>	Cooling	dB(A)	20 - 26 - 32 - 40	22 - 29 - 35 - 42	25 - 31 - 39 - 47
	Heating		20 - 27 - 33 - 40	22 - 30 - 35 - 42	25 - 31 - 39 - 48
Sound power (Eurovent data)			55	60	60
Airflow (very low - low - medium - high)	Cooling	m³/h	300 - 330 - 510 - 560	320 - 340 - 430 - 580	350 - 400 - 580 - 720
	Heating		290 - 370 - 560 - 610	310 - 360 - 480 - 630	350 - 420 - 620 - 800
Pipe diameter (Liquid - Gas)			1/4 - 3/8	1/4 - 3/8	1/4 - 1/2
Condensate Evacuation Diameter			16	16	16
Remote control (standard)			Eco Control	Eco Control	Eco Control
OUTDOOR UNITS			RAC-25WXB	RAC-35WXB	RAC-50WXB
Absorbed nominal power (min-max)	Cooling	kW	0.54 (0.25-1.22)	0.91 (0.25-1.40)	1.56 (0.50-2.10)
	Heating		0.70 (0.25-1.20)	0.95 (0.25-1.60)	1.56 (0.50-2.70)
EER - COP			4.59 - 4.57 (A/A)	3.85 - 4.19 (A/A)	3.21 - 3.72 (A/A)
SEER			8.50	8.50	7.20
SCOP (Average Climate Class)			4.70	4.72	4.50
Energy class <sup>(3)</sup>	Cooling		<b>A+++</b>	<b>A+++</b>	<b>A++</b>
	Heating		<b>A++</b>	<b>A++</b>	<b>A+</b>
Sound pressure level <sup>(4)</sup>	Cooling	dB(A)	46	47	51
	Heating		47	49	51
Airflow	Cooling	m³/h	1860	1920	2160
	Heating		1620	1620	2160
Power supply			230 V, 1 Ph, 50 Hz	230 V, 1 Ph, 50 Hz	230 V, 1 Ph, 50 Hz
Pipe diameter (Liquid - Gas)			1/4 - 3/8	1/4 - 3/8	1/4 - 1/2
Maximum length			20	20	30
Maximum height			10	10	10
Refrigerant charge			1.08 (20)	1.17 (20)	1.35 (30)
Refrigerant fluid			R410A	R410A	R410A
Compressor			Rotating	Rotating	Rotating
PRICE OF THE SET					

(1) The nominal power for cooling and heating is the combined power of the HITACHI standard split system and is based on the following conditions (ISO 5151):  
 - Cooling: indoor temperature 27°C DB, 19°C WB; outdoor temperature 35°C DB.  
 - Heating: indoor temperature 20°C DB; outdoor temperature 7°C DB, 6°C WB.  
 - Pipe length to 5 m; height at 0 m.

(2) The sound level measurement is performed in an anechoic camera 1 m from the discharge grille and 0.8 m below the center of the indoor unit.

(3) Data calculated in compliance with communication prEN14825 and 2012/c 172/01.

(4) The sound level measurement is performed in an anechoic camera at 1 m from the surface and at 1 m from the ground level.

Guaranteed performance

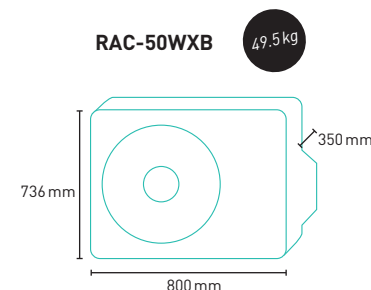
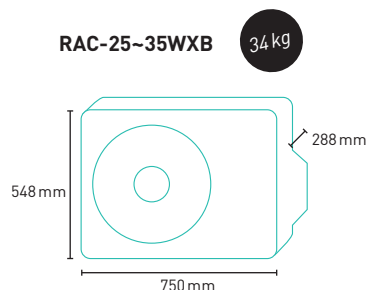
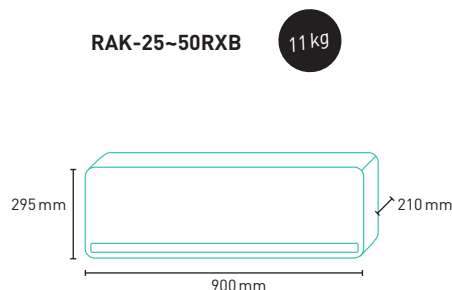
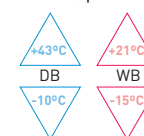

For more information about controls, see page 193.  
 Recommended prices - VAT not included, Waste Electrical and Electronic Equipment Directive (WEEE) fee not included.  
 To create the energy label visit our website [www.hitachiircon.es](http://www.hitachiircon.es) and use our Hitachi ErP Active Tool application.

**WALL MOUNTED**  
DC INVERTER HEAT PUMPS

**PERFORMANCE RPC**  
RAK-18~50RPC // RAK-60~70PPA

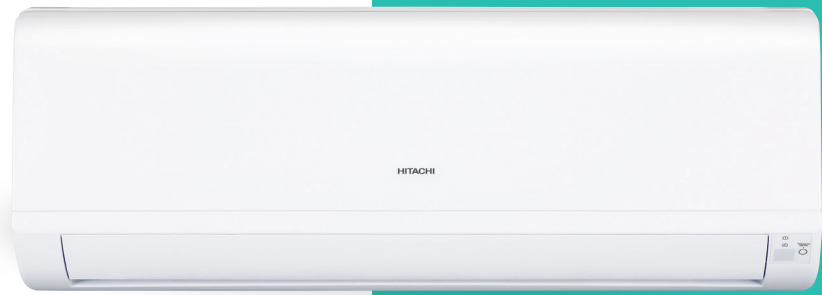

**PERFORMANCE**

**Active carbon-base special AC filter**

It works with a mix of silver-base antibacterial substances. It is sustainable because respects the biocidal regulation, is antiviral, antimicrobial and it has effect on a wide range of odiferous elements.

**Antibacterial washable carbon prefilter**

**Energy class A+++\***

**Sound level from 20 dBA**

Other control options:  
**H-Link Adapter.**

**New wired control SPX-WKT2**

With weekly program. It allows you to choose where to place the temperature sensor and to centralize management of up to 13 indoor units. The maximum distance between the indoor unit and the control is 15 m.

**Eco Control**

It shows real consumption and has custom programs and many more functions that optimize the equipment operation

**Flexibility**

RPC performance is compatible with all Multizone outdoor units.

*Ideal for air-conditioning any room. With 6 different power options, it cools small and large rooms.*

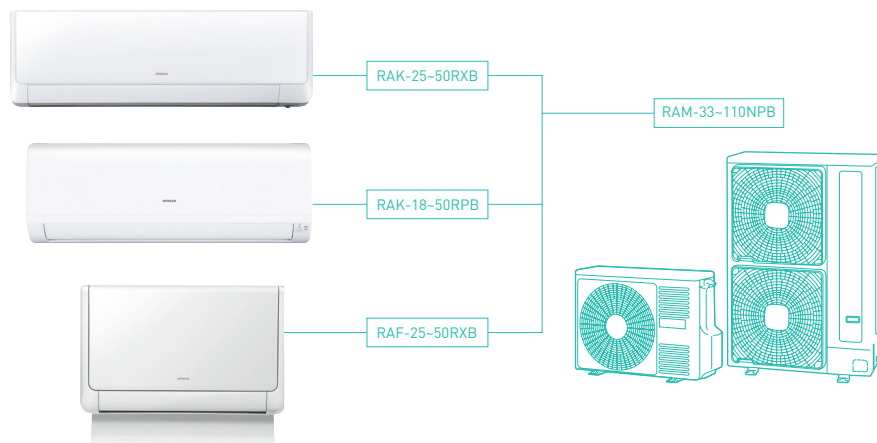

\*Depending on model.



PERFORMANCE RPC

NAME OF THE SET		PERFORMANCE 18 RPC	PERFORMANCE 25 RPC	PERFORMANCE 35 RPC	PERFORMANCE 50 RPC	PERFORMANCE 60 PPA	PERFORMANCE 70 PPA
INDOOR UNITS		RAK-18RPC	RAK-25RPC	RAK-35RPC	RAK-50RPC	RAK-60PPA	RAK-70PPA
Nominal power (min-max) <sup>(1)</sup>	Cooling	2.00 (0.90-2.50)	2.50 (0.90-3.10)	3.50 (0.90-4.00)	5.00 (1.90-5.20)	6.10 (0.90-6.50)	7.00 (1.50-8.00)
	Heating	2.50 (0.90-3.20)	3.40 (0.90-4.40)	4.20 (0.90-5.00)	6.00 (2.20-7.30)	6.80 (0.90-8.50)	8.00 (1.50-9.20)
Sound pressure level (very low - low - medium - high) <sup>(2)</sup>	Cooling	21 - 24 - 33 - 37	22 - 24 - 33 - 40	25 - 26 - 36 - 43	25 - 28 - 39 - 46	30 - 33 - 42 - 48	30 - 33 - 42 - 47
	Heating	19 - 22 - 33 - 38	20 - 23 - 34 - 41	26 - 27 - 36 - 44	27 - 31 - 39 - 46	33 - 34 - 42 - 49	30 - 33 - 42 - 47
Sound power (Eurovent data)		51	54	57	60	63	61
Airflow (very low - low - medium - high)	Cooling	312 - 350 - 400 - 440	333 - 370 - 430 - 510	353 - 420 - 485 - 680	353 - 410 - 540 - 750	480 - 540 - 690 - 930	510 - 630 - 870 - 1020
	Heating	312 - 350 - 420 - 480	333 - 400 - 500 - 570	363 - 480 - 570 - 780	380 - 500 - 610 - 820	480 - 510 - 720 - 1050	510 - 630 - 870 - 1080
Pipe diameter (Liquid - Gas)		1/4 - 3/8	1/4 - 3/8	1/4 - 3/8	1/4 - 1/2	1/4 - 1/2	1/4 - 5/8
Condensate Evacuation Diameter		16	16	16	16	16	16
Remote control (standard)		Eco Control	Eco Control	Eco Control	Eco Control	Eco Control	Eco Control
OUTDOOR UNITS		RAC-18WPC	RAC-25WPC	RAC-35WPC	RAC-50WPC	RAC-60WPA	RAC-70WPA
Absorbed nominal power (min-max)	Cooling	0.55 (0.25-1.01)	0.70 (0.25-1.29)	1.09 (0.25-1.46)	1.56 (0.50-2.10)	1.85 (0.15-2.30)	2.17 (0.20-2.82)
	Heating	0.58 (0.25-0.97)	0.88 (0.25-1.25)	1.10 (0.25-1.70)	1.66 (0.50-2.75)	1.88 (0.12-2.55)	2.20 (0.20-2.97)
EER - COP		3.64 - 4.31 (A/A)	3.57 - 3.86 (A/A)	3.21 - 3.82 (A/A)	3.21 - 3.61 (A/A)	3.30 - 3.62 (A/A)	3.23 - 3.64 (A/A)
SEER		7.00	7.60	7.20	7.20	6.00	6.80
SCOP (Average Climate Class)		4.30	4.40	4.60	4.41	4.00	4.40
Energy class <sup>(3)</sup>	Cooling	A++	A++	A++	A++	A+	A++
	Heating	A+	A+	A++	A+	A+	A+
Sound pressure level <sup>(4)</sup>	Cooling	46	48	49	51	50	52
	Heating	47	49	50	51	53	54
Airflow	Cooling	1860	1860	1920	2160	2160	2820
	Heating	1620	1620	1620	2160	2160	2820
Power supply		230 V, 1 Ph, 50 Hz	230 V, 1 Ph, 50 Hz	230 V, 1 Ph, 50 Hz	230 V, 1 Ph, 50 Hz	220-240 V, 1 Ph, 50 Hz	220-240 V, 1 Ph, 50 Hz
Pipe diameter (Liquid - Gas)		1/4 - 3/8	1/4 - 3/8	1/4 - 3/8	1/4 - 1/2	1/4 - 1/2	1/4 - 5/8
Maximum length		20	20	20	20	30	30
Maximum height		10	10	10	10	20	20
Refrigerant charge		0.95 (20)	0.95 (20)	1.05 (20)	1.25 (20)	1.65 (30)	1.85 (30)
Refrigerant fluid		R410A	R410A	R410A	R410A	R410A	R410A
Compressor		Rotating	Rotating	Rotating	Rotating	DC Twin Rotary	DC Twin Rotary
PRICE OF THE SET							

(1) The nominal power for cooling and heating is the combined power of the HITACHI standard split system and is based on the following conditions (ISO 5151):  
 - Cooling: indoor temperature 27°C DB, 19°C WB; outdoor temperature 35°C DB.  
 - Heating: indoor temperature 20°C DB; outdoor temperature 7°C DB, 6°C WB.  
 - Pipe length to 5 m; height at 0 m.  
 (2) The sound level measurement is performed in an anechoic camera 1 m from the discharge grille and 0.8 m below the center of the indoor unit.  
 (3) Data calculated in compliance with communication prEN14825 and 2012/c 172/01.  
 (4) The sound level measurement is performed in an anechoic camera at 1 m from the surface and at 1 m from the ground level.

Guaranteed performance

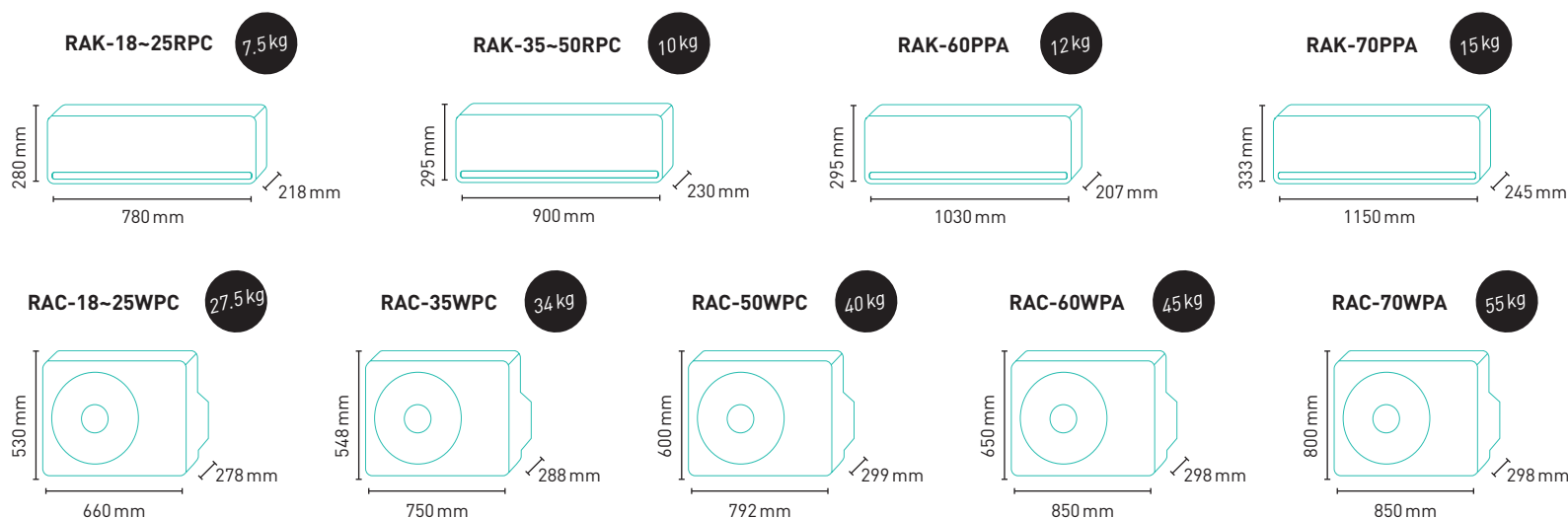
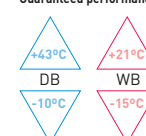

For more information about controls, see page 193.  
 Recommended prices - VAT not included, Waste Electrical and Electronic Equipment Directive (WEEE) fee not included.  
 To create the energy label visit our website [www.hitachiircon.es](http://www.hitachiircon.es) and use our Hitachi ErP AcTive Tool application.

**WALL MOUNTED**  
DC INVERTER HEAT PUMPS

**ENTRY PEC**  
RAK 18-50PEC

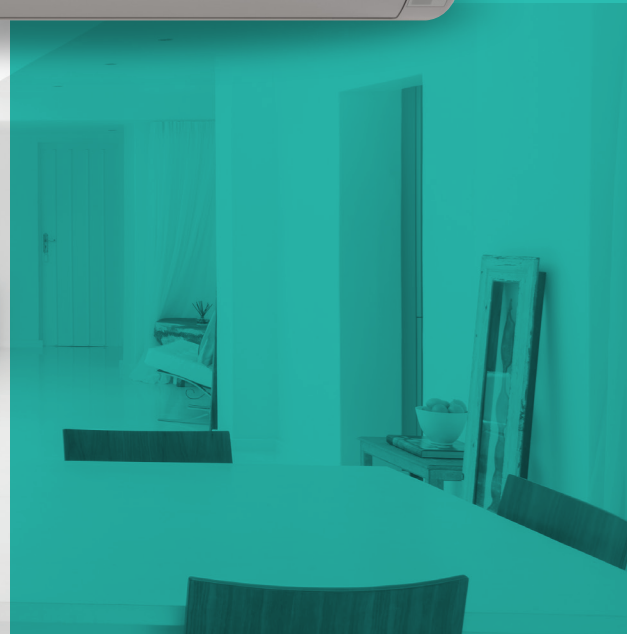
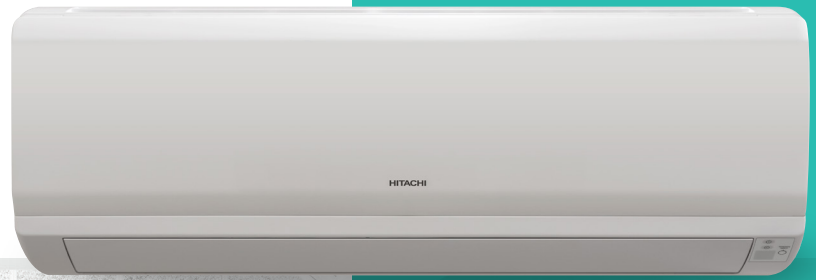

**CHARACTERISTICS**

**Optional filter**

The Active carbon-base AC filter can be installed as an option .

**Wi-Fi**

This model is Wi-Fi compatible and it can support an Home automation system.

**Energy class A+/A**

Other control options:  
**H-Link Adapter.**

**New wired control SPX-WKT2**

With weekly programming, it allows you to choose where to place the temperature sensor and to centralize management of up to 13 indoor units. The maximum distance between the indoor unit and the control is 15 m.



## ENTRY PEC

NAME OF THE SET		ENTRY 18 PEC	ENTRY 25 PEC	ENTRY 35 PEC	ENTRY 50 PEC
INDOOR UNITS		RAK-18PEC	RAK-25PEC	RAK-35PEC	RAK-50PEC
Nominal power (min-max) <sup>(1)</sup>	Cooling	2.00 (0.90-2.50)	2.50 (0.90-3.10)	3.50 (0.90-4.00)	5.00 (1.90-5.20)
	Heating	2.50 (0.90-3.20)	3.40 (0.90-4.40)	4.20 (0.90-5.00)	6.00 (2.2-7.30)
Sound pressure level (very low - low - medium - high) <sup>(2)</sup>	Cooling	21-24-33-37	22-24-33-40	25-26-36-43	28-30-40-46
	Heating	19-22-33-38	20-23-34-41	26-27-36-44	25-30-39-47
Sound power (Eurovent data)		51	54	57	60
Airflow (very low - low - medium - high)	Cooling	312 - 350 - 400 - 440	333 - 370 - 430 - 510	333 - 400 - 485 - 600	333 - 450 - 600 - 700
	Heating	312 - 350 - 420 - 480	333 - 400 - 500 - 570	333 - 520 - 550 - 660	433 - 510 - 650 - 770
Pipe diameter (Liquid - Gas)	inches	1/4 - 3/8	1/4 - 3/8	1/4 - 3/8	1/4 - 1/2
Condensate Evacuation Diameter	mm	16	16	16	16
Remote control (standard)		RAR-5F1	RAR-5F1	RAR-5F1	RAR-5F1
OUTDOOR UNITS		RAC-18WEC	RAC-25WEC	RAC-35WEC	RAC-50WEC
Absorbed nominal power (min-max)	Cooling	0.58 (0.25-1.01)	0.70 (0.25-1.29)	1.090 (0.25-1.46)	1.560 (0.50-2.10)
	Heating	0.62 (0.25-0.97)	0.88 (0.25-1.25)	1.100 (0.25-1.70)	1.660 (0.50-2.75)
EER - COP		3.45 - 4.03	3.57 - 3.86	3.21 - 3.82	3.21 - 3.61
SEER		5,8	5,8	5,85	5,88
SCOP (Average Climate Class)		3,8	3,8	3,8	3,8
Energy class <sup>(3)</sup>	Cooling	<b>A+</b>	<b>A+</b>	<b>A+</b>	<b>A+</b>
	Heating	<b>A</b>	<b>A</b>	<b>A</b>	<b>A</b>
Sound pressure level <sup>(4)</sup>	Cooling	45	47	48	50
	Heating	46	48	49	50
Airflow	Cooling	1860	1860	1860	2160
	Heating	1620	1620	1620	2160
Power supply		230 V, 1 Ph, 50 Hz	230 V, 1 Ph, 50 Hz	230 V, 1 Ph, 50 Hz	230 V, 1 Ph, 50 Hz
Pipe diameter (Liquid - Gas)	inches	1/4 - 3/8	1/4 - 3/8	1/4 - 3/8	1/4 - 1/2
Maximum length		20	20	20	20
Maximum height		10	10	10	10
Refrigerant charge	kg (m)	0.72 (20)	0.72 (20)	0.95 (20)	1.25 (20)
Refrigerant fluid		R410A	R410A	R410A	R410A
Compressor		ROTARY	ROTARY	ROTARY	ROTARY
PRICE OF THE SET					

(1) The nominal power for cooling and heating is the combined power of the HITACHI standard split system and is based on the following conditions (ISO 5151):  
 - Cooling: indoor temperature 27°C DB, 19°C WB; outdoor temperature 35°C DB.  
 - Heating: indoor temperature 20°C DB; outdoor temperature 7°C DB, 6°C WB.  
 - Pipe length to 5 m; height at 0 m.

(2) The sound level measurement is performed in an anechoic camera 1 m from the discharge grille and 0.8 m below the center of the indoor unit.  
 (3) Data calculated in compliance with communication prEN14825 and 2012/c 172/01.  
 (4) The sound level measurement is performed in an anechoic camera at 1 m from the surface and at 1 m from the ground level.

Guaranteed performance

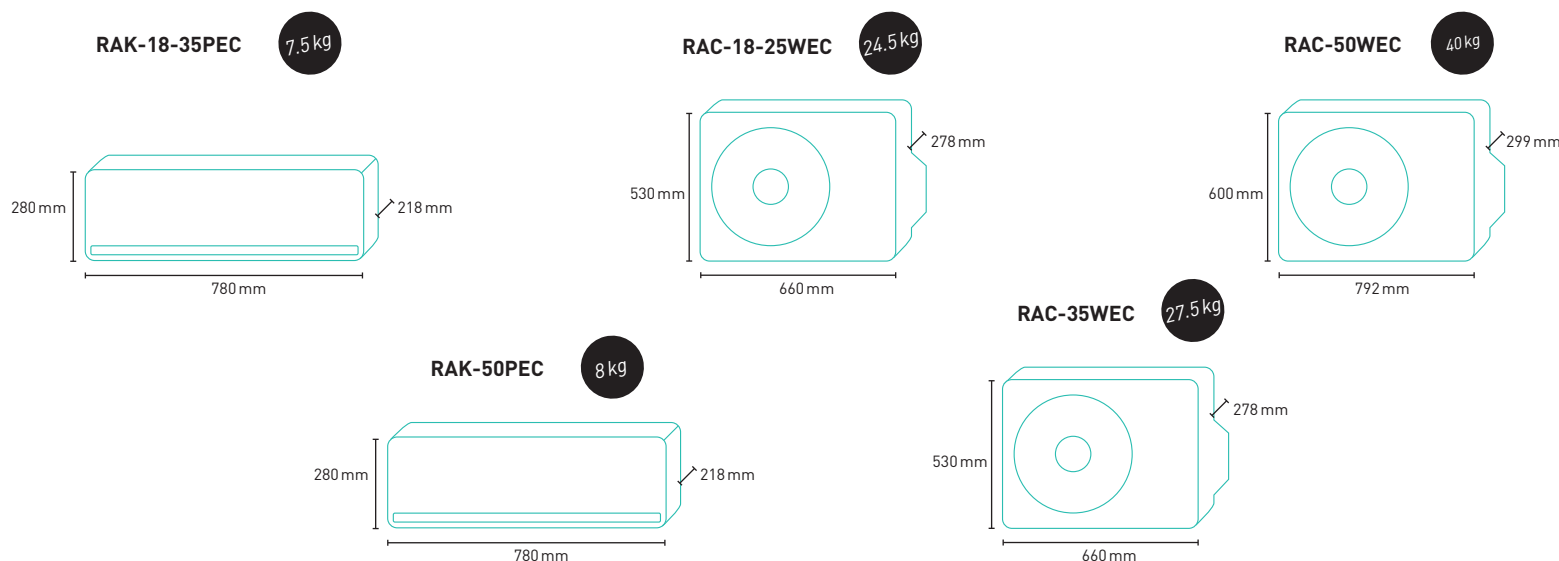
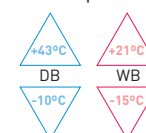

For more information about controls, see page 193.  
 Recommended prices - VAT not included, Waste Electrical and Electronic Equipment Directive (WEEE) fee not included.  
 To create the energy label visit our website [www.hitachiircon.es](http://www.hitachiircon.es) and use our Hitachi ErP AcTive Tool application.



## WALL MOUNTED DC INVERTER HEAT PUMPS

### ENTRY PED RAK 18-50PED

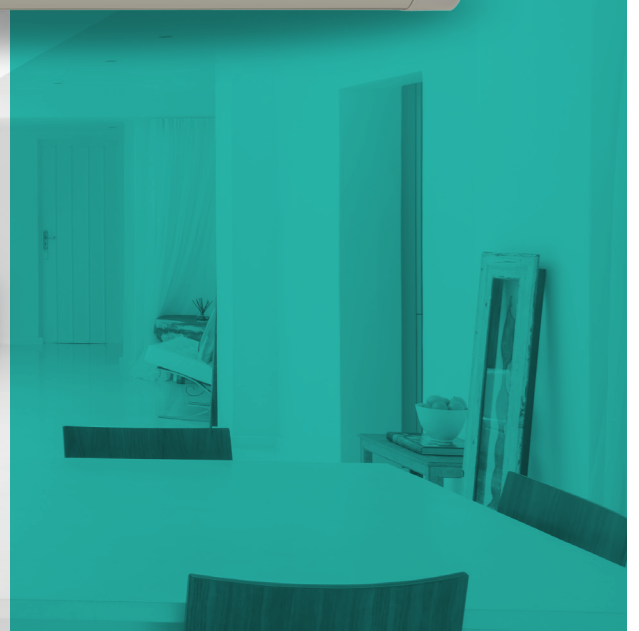
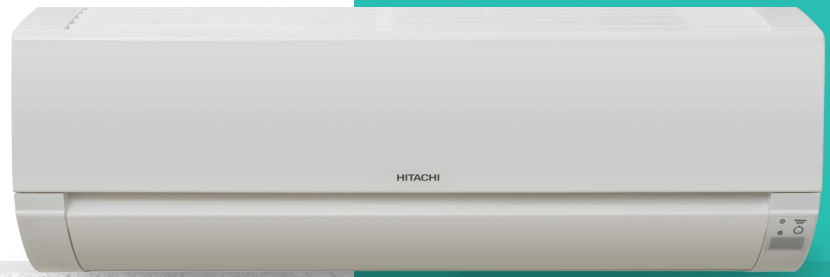

#### CHARACTERISTICS

##### Optional filter

The Active carbon-base AC filter can be installed as an option.

##### Wi-Fi

This model is Wi-Fi compatible and it can support an Home automation system.

##### Refrigerant

This is the Entry model with the R32 refrigerant, with a lower GWP.

##### Energy class A++/A+

Other control options:  
**H-Link Adapter.**

##### New wired control SPX-WKT2

With weekly programming, it allows you to choose where to place the temperature sensor and to centralize management of up to 13 indoor units. The maximum distance between the indoor unit and the control is 15 m.





## ENTRY PED

NAME OF THE SET		ENTRY 18 PED	ENTRY 25 PED	ENTRY 35 PED	ENTRY 50 PED
INDOOR UNITS		RAK-18PED	RAK-25PED	RAK-35PED	RAK-50PED
Nominal power (min-max) <sup>(1)</sup>	Cooling	2.00 (0.90-2.50)	2.50 (0.90-3.10)	3.50 (0.90-4.00)	5.00 (1.90-5.20)
	Heating	2.50 (0.90-3.20)	3.40 (0.90-4.40)	4.20 (0.90-5.00)	6.00 (2.2-7.30)
Sound pressure level (very low - low - medium - high) <sup>(2)</sup>	Cooling	21 - 24 - 33 - 37	22 - 24 - 33 - 40	25 - 26 - 36 - 43	28 - 30 - 40 - 46
	Heating	19 - 22 - 33 - 38	20 - 23 - 34 - 41	26 - 27 - 36 - 44	25 - 30 - 39 - 47
Sound power (Eurovent data)		51	54	57	60
Airflow (very low - low - medium - high)	Cooling	312 - 350 - 400 - 440	333 - 370 - 430 - 510	333 - 400 - 485 - 600	333 - 450 - 600 - 700
	Heating	312 - 350 - 420 - 480	333 - 400 - 500 - 570	333 - 520 - 550 - 660	433 - 510 - 650 - 770
Pipe diameter (Liquid - Gas)	inches	1/4 - 3/8	1/4 - 3/8	1/4 - 3/8	1/4 - 1/2
Condensate Evacuation Diameter	mm	16	16	16	16
Remote control (standard)		RAR-5F1	RAR-5F1	RAR-5F1	RAR-5F1
OUTDOOR UNITS		RAC-18WED	RAC-25WED	RAC-35WED	RAC-50WED
Absorbed nominal power (min-max)	Cooling	0.58 (0.25-1.01)	0.70 (0.25-1.29)	1.090 (0.25-1.46)	1.560 (0.50-2.10)
	Heating	0.62 (0.25-0.97)	0.88 (0.25-1.25)	1.100 (0.25-1.70)	1.660 (0.50-2.75)
EER - COP		3.45 - 4.03	3.57 - 3.86	3.21 - 3.82	3.21 - 3.61
SEER		6,1	6,1	6,1	6,1
SCOP (Average Climate Class)		4,2	4,2	4,2	4,3
Energy class <sup>(3)</sup>	Cooling	<b>A++</b>	<b>A++</b>	<b>A++</b>	<b>A++</b>
	Heating	<b>A+</b>	<b>A+</b>	<b>A+</b>	<b>A+</b>
Sound pressure level <sup>(4)</sup>	Cooling	45	47	48	50
	Heating	46	48	49	50
Airflow	Cooling	1860	1860	1860	2160
	Heating	1620	1620	1620	2160
Power supply		230 V, 1 Ph, 50 Hz	230 V, 1 Ph, 50 Hz	230 V, 1 Ph, 50 Hz	230 V, 1 Ph, 50 Hz
Pipe diameter (Liquid - Gas)	inches	1/4 - 3/8	1/4 - 3/8	1/4 - 3/8	1/4 - 1/2
Maximum length	m	20	20	20	20
Maximum height	m	10	10	10	10
Refrigerant charge	kg (m)	0.53 (20)	0.53 (20)	0.7 (20)	0.93 (20)
Refrigerant fluid		R32	R32	R32	R32
Compressor		ROTARY	ROTARY	ROTARY	ROTARY
PRICE OF THE SET					

(1) The nominal power for cooling and heating is the combined power of the HITACHI standard split system and is based on the following conditions (ISO 5151):  
 - Cooling: indoor temperature 27°C DB, 19°C WB; outdoor temperature 35°C DB.  
 - Heating: indoor temperature 20°C DB; outdoor temperature 7°C DB, 6°C WB.  
 - Pipe length to 5 m; height at 0 m.

(2) The sound level measurement is performed in an anechoic camera 1 m from the discharge grille and 0.8 m below the center of the indoor unit.

(3) Data calculated in compliance with communication prEN14825 and 2012/c 172/01.

(4) The sound level measurement is performed in an anechoic camera at 1 m from the surface and at 1 m from the ground level.

Guaranteed performance

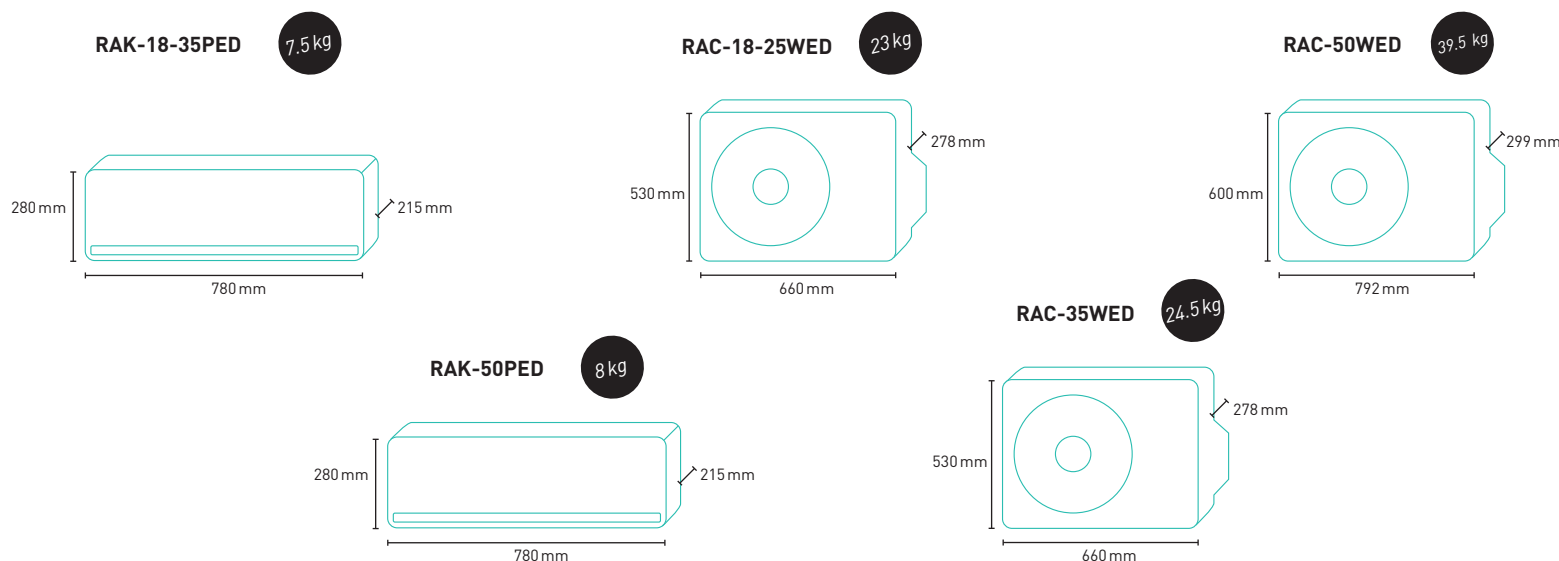
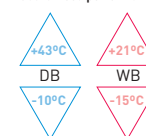

For more information about controls, see page 193.  
 Recommended prices - VAT not included, Waste Electrical and Electronic Equipment Directive (WEEE) fee not included.  
 To create the energy label visit our website [www.hitachiircon.es](http://www.hitachiircon.es) and use our Hitachi ErP Active Tool application.

## FLOOR DC INVERTER HEAT PUMPS

# AKEBONO F RXB

RAF-25~50RXB



## CHARACTERISTICS

### Eco Control

It shows real consumption and has custom programs and many more functions that optimize the equipment operation.

**Eco Mode** prevents non-necessary consumption because it regulates its operation based on the setpoint temperature.

### Nano Titanium Filter

Eliminates bacteria, allergens and bad odors.

Other control options:  
**H-Link Adapter.**

### Energy class A+++\*

### New wired control SPX-WKT2

With weekly program.  
It allows you to choose where to place the temperature sensor and to centralize management of up to 13 indoor units.  
The maximum distance between the indoor unit and the control is 15 m.

### Flexibility

RPC performance is compatible with all Multizone outdoor units.

### Extended airflow

Enjoy the suitable temperature in every corner of the room.

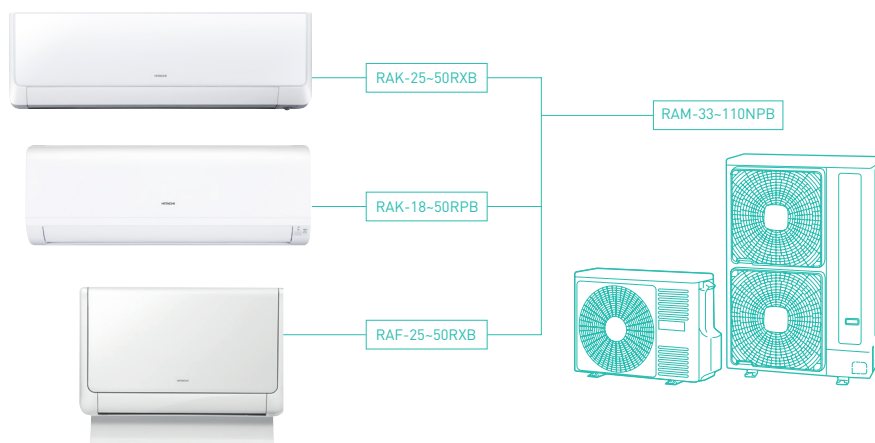

\*Depending on model.

*Its unobtrusive design combines with all decoration styles. Ideal for installing in rooms where the ceiling is not very high. Its air deflector air-conditions the room in very little time.*





## AKEBONO F RXB

NAME OF THE SET			AKEBONO F25 RXB	AKEBONO F 35 RXB	AKEBONO F 50 RXB
INDOOR UNITS			RAF-25RXB	RAF-35RXB	RAF-50RXB
Nominal power (min-max) <sup>(1)</sup>	Cooling	kW	2.50 (0.90-3.10)	3.50 (0.90-4.00)	5.00 (0.90-5.20)
	Heating		3.40 (0.90-4.40)	4.50 (0.90-5.00)	6.00 (0.90-8.10)
Sound pressure level (very low - low - medium - high) <sup>(2)</sup>	Cooling	dB(A)	20 - 26 - 31 - 38	20 - 26 - 31 - 39	22 - 29 - 36 - 43
	Heating		20 - 26 - 31 - 38	20 - 26 - 31 - 39	22 - 29 - 36 - 44
Sound power (Eurovent data)			55	56	59
Airflow (very low - low - medium - high)	Cooling	m³/h	270 - 390 - 510 - 630	270 - 390 - 510 - 660	300 - 450 - 540 - 720
	Heating		300 - 420 - 540 - 660	300 - 420 - 540 - 690	330 - 480 - 570 - 750
Pipe diameter (Liquid - Gas)			1/4 - 3/8	1/4 - 3/8	1/4 - 1/2
Condensate Evacuation Diameter			16	16	16
Remote control (standard)			Eco Control	Eco Control	Eco Control
OUTDOOR UNITS			RAC-25FXB	RAC-35FXB	RAC-50FXB
Absorbed nominal power (min-max)	Cooling	kW	0.58 (0.15-1.18)	1.02 (0.15-1.38)	1.56 (0.50-2.10)
	Heating		0.79 (0.11-1.12)	1.22 (0.11-1.35)	1.60 (0.50-2.70)
EER - COP			4.31 - 4.30 (A/A)	3.43 - 3.69 (A/A)	3.21 - 3.75 (A/A)
SEER			6.38	6.39	5.97
SCOP (Average Climate Class)			4.24	4.14	4.15
Energy class <sup>(3)</sup>	Cooling		<b>A++</b>	<b>A++</b>	<b>A+</b>
	Heating		<b>A+</b>	<b>A+</b>	<b>A+</b>
Sound pressure level <sup>(4)</sup>	Cooling	dB(A)	45	46	50
	Heating		47	48	52
Airflow	Cooling	m³/h	1860	1920	2160
	Heating		1620	1620	2160
Power supply			230 V, 1 Ph, 50 Hz	230 V, 1 Ph, 50 Hz	230 V, 1 Ph, 50 Hz
Pipe diameter (Liquid - Gas)			1/4 - 3/8	1/4 - 3/8	1/4 - 1/2
Maximum length			20	20	30
Maximum height			10	10	10
Refrigerant charge			0.87 (20)	0.87 (20)	1.40 (30)
Refrigerant fluid			R410A	R410A	R410A
Compressor			DC Scroll	DC Scroll	Rotating
INDOOR UNIT PRICE (INCLUDES CONTROL)					
OUTDOOR UNIT PRICE					
PRICE OF THE SET					

(1) The nominal power for cooling and heating is the combined power of the HITACHI standard split system and is based on the following conditions (ISO 5151):  
 - Cooling: indoor temperature 27°C DB, 19°C WB; outdoor temperature 35°C DB.  
 - Heating: indoor temperature 20°C DB; outdoor temperature 7°C DB, 6°C WB.  
 - Pipe length to 5 m; height at 0 m.

(2) The sound level measurement is performed in an anechoic camera 1 m from the discharge grille and 0.8 m below the center of the indoor unit.

(3) Data calculated in compliance with communication prEN14825 and 2012/c 172/01.

(4) The sound level measurement is performed in an anechoic camera at 1 m from the surface and at 1 m from the ground level.

Guaranteed performance

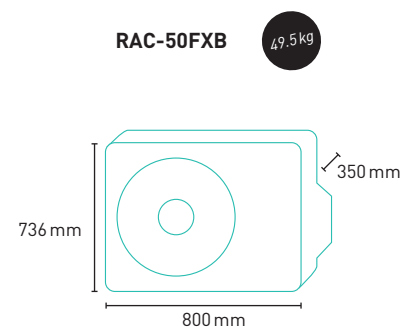
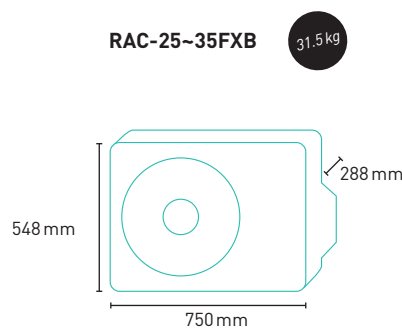
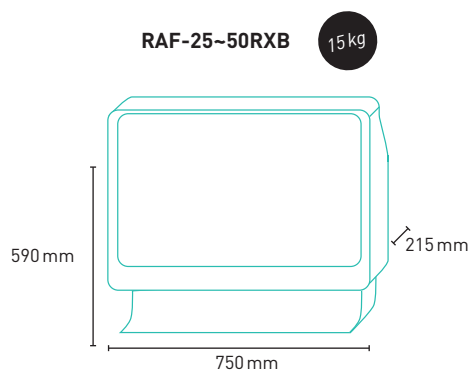
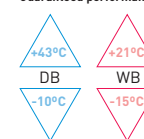

For more information about controls, see page 193.  
 Recommended prices - VAT not included, Waste Electrical and Electronic Equipment Directive (WEEE) fee not included.  
 To create the energy label visit our website [www.hitachiircon.es](http://www.hitachiircon.es) and use our Hitachi ErP Active Tool application.

**FLOOR**  
DC INVERTER HEAT PUMPS

**PERFORMANCE RPA**  
RAF-25~50RPA



**CHARACTERISTICS**

**Eco Control**

It shows real consumption and has custom programs and many more functions that optimize the equipment operation.

**Eco Mode** prevents non-necessary consumption because it regulates its operation based on the setpoint temperature.

**High performance Lambda heat exchanger**

Reaches the setpoint temperature faster.

**Nano Titanium Filter**

Eliminates bacteria, allergens and bad odors.

Other control options:  
**New wired control.**

**Energy class A++\***

**Easy to clean prefilter**

Its wave-like shape captures three times as much dust and is easily removed for cleaning.

**Airflow control with interior deflector**

The deflector keeps air jets from blowing directly on people. Air is distributed towards the floor when heating and distributed upwards when cooling.

*The setpoint temperature is reached quickly, thanks to its LAMBDA heat exchanger. Airflow control is perfected with the interior deflector, thus in heating mode the air is directed towards the floor and it is blown upwards throughout the room when cooling, not blowing directly on people.*

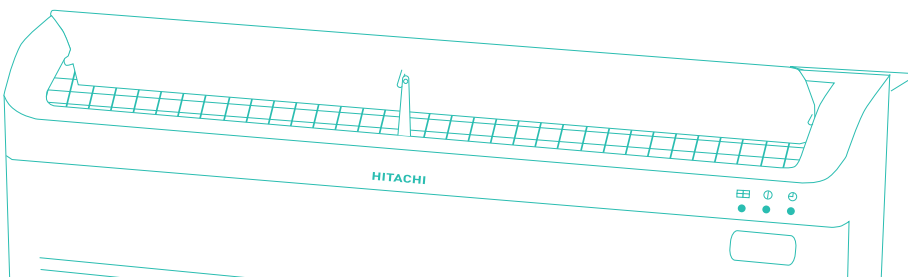

\*Depending on model.

Airflow Control



## PERFORMANCE RPA

NAME OF THE SET		PERFORMANCE 25 RPA	PERFORMANCE 35 RPA	PERFORMANCE 50 RPA
INDOOR UNITS		RAF-25RPA	RAF-35RPA	RAF-50RPA
Nominal power (min-max) <sup>(1)</sup>	Cooling	2.50 (0.90-3.10)	3.50 (1.10-4.00)	5.00 (1.90-5.20)
	Heating	3.40 (0.90-4.40)	4.20 (1.10-5.20)	6.00 (2.20-7.30)
Sound pressure level (very low - low - medium - high) <sup>(2)</sup>	Cooling	23 - 26 - 32 - 40	25 - 29 - 35 - 42	25 - 30 - 37 - 46
	Heating	23 - 27 - 33 - 40	26 - 30 - 35 - 42	25 - 30 - 37 - 47
Sound power (Eurovent data)		54	56	60
Airflow (very low - low - medium - high)	Cooling	378 - 462 - 540	400 - 485 - 600	430 - 530 - 650
	Heating	408 - 498 - 600	440 - 525 - 600	470 - 570 - 720
Pipe diameter (Liquid - Gas)	inches	1/4 - 3/8	1/4 - 3/8	1/4 - 1/2
Condensate Evacuation Diameter	mm	16	16	16
Remote control (standard)		Eco Control	Eco Control	Eco Control
OUTDOOR UNITS		RAC-25FPA	RAC-35FPA	RAC-50FPA
Absorbed nominal power (min-max)	Cooling	0.67 (0.25-1.29)	0.94 (0.25-1.40)	1.51 (0.50-2.10)
	Heating	0.85 (0.25-1.25)	1.05 (0.25-1.80)	1.66 (0.50-2.70)
EER - COP		3.73 - 4.00 (A/A)	3.72 - 4.00 (A/A)	3.31 - 3.61 (A/A)
SEER		5.80	6.00	5.86
SCOP (Average Climate Class)		4.30	4.30	4.00
Energy class <sup>(3)</sup>	Cooling	A+	A+	A+
	Heating	A+	A+	A+
Sound pressure level <sup>(4)</sup>	Cooling	47	48	51
	Heating	49	49	52
Airflow	Cooling	1860	1920	2160
	Heating	1620	1620	2160
Power supply		230 V, 1 Ph, 50 Hz	230 V, 1 Ph, 50 Hz	230 V, 1 Ph, 50 Hz
Pipe diameter (Liquid - Gas)	inches	1/4 - 3/8	1/4 - 3/8	1/4 - 1/2
Maximum length	m	20	20	20
Maximum height	m	10	10	10
Refrigerant charge	kg (m)	0.87 (20)	1.05 (20)	1.25 (20)
Refrigerant fluid		R410A	R410A	R410A
Compressor		Rotating	Rotating	Rotating
INDOOR UNIT PRICE (INCLUDES CONTROL)				
OUTDOOR UNIT PRICE				
PRICE OF THE SET				

(1) The nominal power for cooling and heating is the combined power of the HITACHI standard split system and is based on the following conditions (ISO 5151):  
 - Cooling: indoor temperature 27°C DB, 19°C WB; outdoor temperature 35°C DB.  
 - Heating: indoor temperature 20°C DB; outdoor temperature 7°C DB, 6°C WB.  
 - Pipe length to 5 m; height at 0 m.  
 (2) The sound level measurement is performed in an anechoic camera 1 m from the discharge grille and 0.8 m below the center of the indoor unit.  
 (3) Data calculated in compliance with communication prEN14825 and 2012/c 172/01.  
 (4) The sound level measurement is performed in an anechoic camera at 1 m from the surface and at 1 m from the ground level.

Guaranteed performance

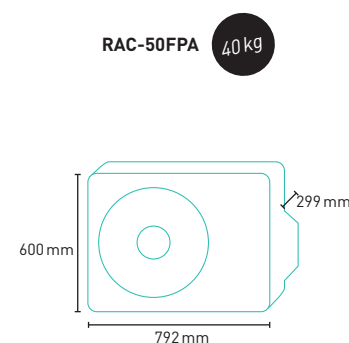
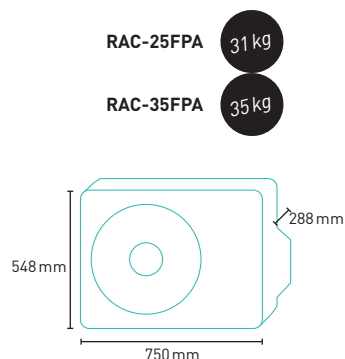
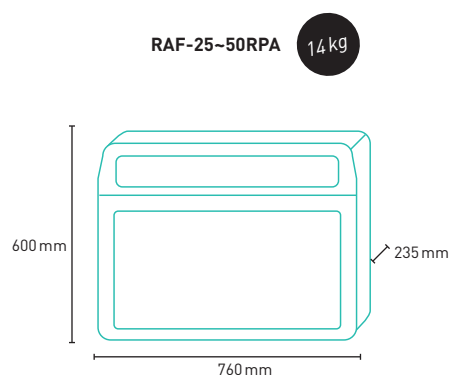

For more information about controls, see page 193.  
 Recommended prices - VAT not included, Waste Electrical and Electronic Equipment Directive (WEEE) fee not included.  
 To create the energy label visit our website [www.hitachiaircon.es](http://www.hitachiaircon.es) and use our Hitachi ErP Active Tool application.



**DUCTS**

DC INVERTER HEAT PUMP

**RAD RPA MONODUCT**

RAD - 25~50RPA // RAD - 50~70PPA

**CHARACTERISTICS****Energy class A\*****Removable prefilter****Eco Mode**

Prevents non-necessary consumption because its operation is regulated based on the setpoint temperature.

Other control options:

**Wired remote control with weekly programmer.**

**Eco Control, (SPX-RCKA).**

**H-Link Adapter.**

**DC Twin Rotary Compressor****Ducts extendible up to 4m**

Installation is possible with fully deployed ducts, half deployed ducts, or ductless units.

**Air inlet of your choice**

The air entrance and exit distribution system can be chosen according to the structure of the building and the width of the room.

**Integrated drainage pump**

It is automatically activated to eliminate the condensation water accumulated in the tray, even during operation.

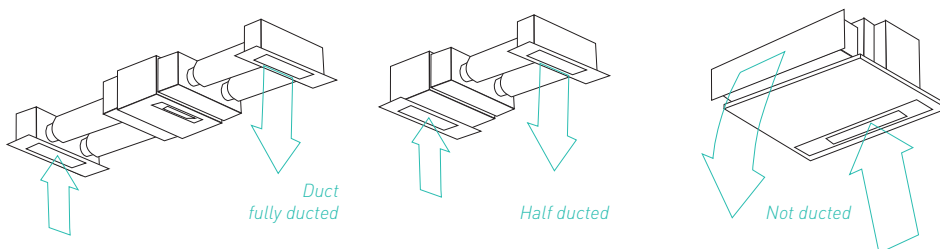

\*Depending on model.

*Ideal for pre-installations of ducts.  
The unit can distribute the air in any possible installation with a maximum length of 4 m, thanks to the high pressure switch.*



## RAD RPA MONODUCT

NAME OF THE SET		MONODUCT RAD 25 RPA	MONODUCT RAD 35 RPA	MONODUCT RAD 50 RPA	MONODUCT RAD 50 PPA	MONODUCT RAD 60 PPA	MONODUCT RAD 70 PPA
INDOOR UNITS		RAD-25RPA	RAD-35RPA	RAD-50RPA	RAD-50PPA	RAD-60PPA	RAD-70PPA
Nominal power (min-max) <sup>[1]</sup>	Cooling	2.50 (0.90-3.00)	3.50 (0.90-4.00)	5.00 (0.90-5.60)	5.00 (0.90-6.00)	6.00 (0.90-7.00)	7.10 (0.90-8.00)
	Heating	3.50 (0.90-5.55)	4.80 (0.90-6.60)	6.00 (0.90-7.50)	6.00 (0.90-7.00)	7.30 (0.90-8.00)	8.00 (0.90-9.00)
Sound pressure level (very low - low - medium - high) <sup>[2]</sup>	Cooling	29 - 31 - 34 - 36	29 - 31 - 34 - 36	29 - 32 - 35 - 38	28 - 30 - 32 - 34	28 - 30 - 32 - 34	28 - 30 - 32 - 35
	Heating	27 - 30 - 33 - 37	27 - 30 - 33 - 37	29 - 32 - 35 - 38	29 - 31 - 33 - 35	29 - 31 - 33 - 35	29 - 31 - 33 - 36
Sound power (Eurovent data)		57	57	58	60	60	61
Airflow (very low - low - medium - high)	Cooling	330 - 390 - 450 - 510	330 - 390 - 450 - 510	330 - 360 - 450 - 510	618 - 660 - 780 - 900	618 - 660 - 780 - 900	618 - 660 - 780 - 960
	Heating	360 - 420 - 480 - 600	360 - 420 - 480 - 600	360 - 420 - 480 - 630	618 - 660 - 780 - 900	618 - 660 - 780 - 900	618 - 660 - 780 - 960
Pipe diameter (Liquid - Gas)		1/4 - 3/8	1/4 - 3/8	1/4 - 1/2	1/4 - 1/2	1/4 - 1/2	1/4 - 5/8
Condensate Evacuation Diameter		16	16	16	16	16	16
Remote control (not standard)		Wired remote control, with 12 h program compatible with Eco Control					
OUTDOOR UNITS		RAC-25NPA	RAC-35NPA	RAC 50NPA	RAC-50DPA	RAC-60DPA	RAC-70DPA
Absorbed nominal power (min-max)	Cooling	0.69 (0.15-1.05)	1.24 (0.15-1.28)	2.00 (0.15-2.06)	1.40 (0.20-2.10)	1.87 (0.20-2.50)	2.53 (0.20-2.92)
	Heating	0.97 (0.11-1.40)	1.70 (0.11-1.92)	2.30 (0.11-2.53)	1.59 (0.20-2.20)	2.13 (0.20-2.60)	2.34 (0.20-3.10)
EER - COP		3.60 - 3.61 (A/A)	2.82 - 2.82 (C/D)	2.50 - 2.61 (E/E)	3.57 - 3.77 (A/A)	3.21 - 3.43 (A/B)	2.81 - 3.42 (C/B)
SEER		5.10	5.10	4.70	5.10	4.80	4.80
SCOP (Average Climate Class)		3.80	3.80	3.80	3.80	3.80	3.80
Energy class <sup>[3]</sup>	Cooling	A	A	B	A	B	B
	Heating	A	A	A	A	A	A
Sound pressure level <sup>[4]</sup>	Cooling	46	47	50	47	48	53
	Heating	46	49	52	50	51	55
Airflow	Cooling	1620	1620	2160	2700	2700	2820
	Heating	1620	1620	2160	2700	2700	2820
Power Supply		220-240 V, 1 Ph, 50 Hz	220-240 V, 1 Ph, 50 Hz	220-240 V, 1 Ph, 50 Hz	220-230 V, 1 Ph, 50 Hz	220-230 V, 1 Ph, 50 Hz	220-230 V, 1 Ph, 50 Hz
Pipe diameter (Liquid - Gas)		1/4 - 3/8	1/4 - 3/8	1/4 - 1/2	1/4 - 1/2	1/4 - 1/2	1/4 - 5/8
Maximum length		20	20	20	30	30	30
Maximum height		10	10	10	20	20	20
Refrigerant charge		1.15 (20)	1.15 (20)	1.40 (20)	1.80 (30)	1.80 (30)	1.80 (30)
Refrigerant fluid		R410A	R410A	R410A	R410A	R410A	R410A
Compressor		DC Twin Rotary	DC Twin Rotary	DC Twin Rotary	DC Twin Rotary	DC Twin Rotary	DC Twin Rotary
INDOOR UNIT PRICE							
OUTDOOR UNIT PRICE							
SPX-RCDA CONTROL PRICE							
ECO CONTROL PRICE (WITH RECEPTOR)							

[1] The nominal power for cooling and heating is the combined power of the HITACHI standard split system and is based on the following conditions (ISO 5151):  
 - Cooling: indoor temperature 27°C DB, 19°C WB; outdoor temperature 35°C DB.  
 - Heating: indoor temperature 20°C DB; outdoor temperature 7°C DB, 6°C WB.  
 - Pipe length to 5 m; height at 0 m.  
 [2] The sound level measurement is performed in an anechoic camera 1 m from the discharge grille and 0.8 m below the center of the indoor unit.  
 [3] Data calculated in compliance with communication prEN14825 and 2012/c 172/01.  
 [4] The sound level measurement is performed in an anechoic camera at 1 m from the surface and at 1 m from the ground level.

Guaranteed performance

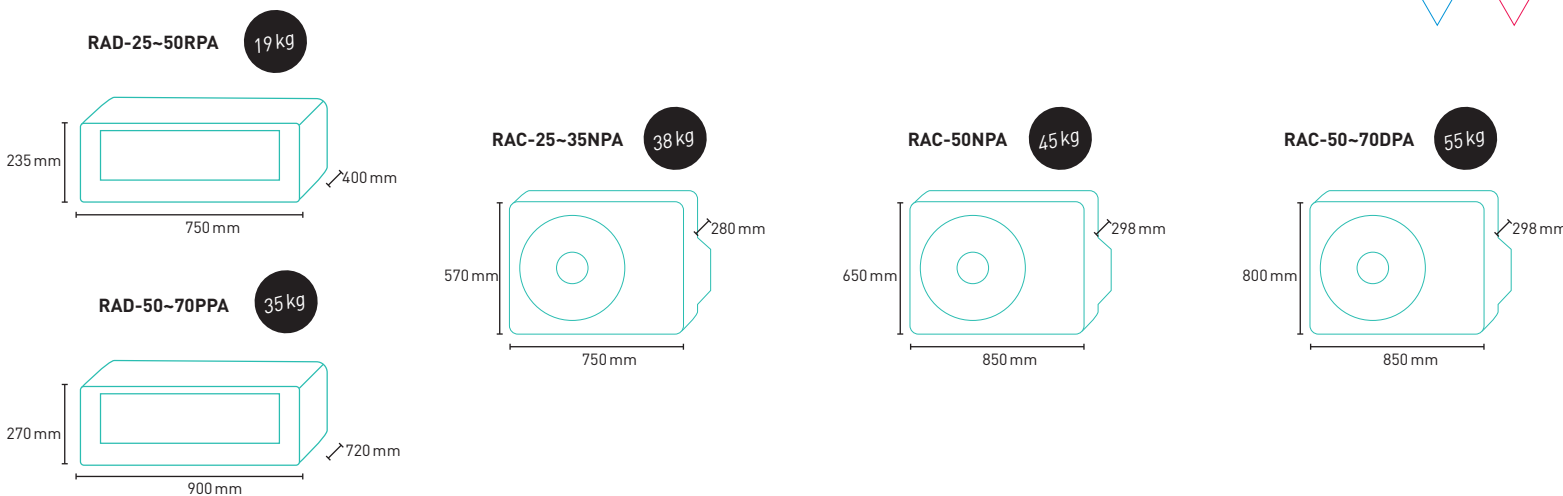
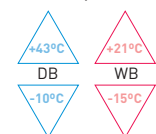

For more information about controls, see page 193.  
 Recommended prices - VAT not included, Waste Electrical and Electronic Equipment Directive (WEEE) fee not included.  
 To create the energy label visit our website [www.hitachiircon.es](http://www.hitachiircon.es) and use our Hitachi ErP AcTive Tool application.



## CASSETTE

### DC INVERTER HEAT PUMPS

# RAI RPA CASSETTE

## RAD-25~50RPA

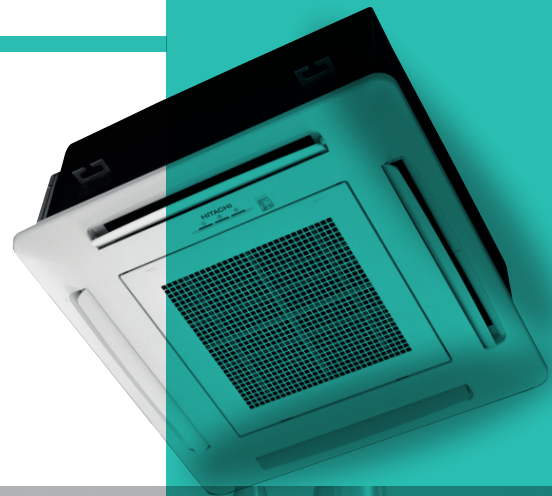

### CHARACTERISTICS

#### Up to 4-way air flow, of your choice

Swing ventilation grille  
automatic quiet operation: only 25dBA.

Other control options:

**Wired remote control with 12 hour programmer. H-Link Adapter.**

#### Energy class A+\*

#### One touch panel

With one click the panel opens up to 90°C.  
It has an easily removable filter for cleaning and/or maintenance.

#### Eco Control

It shows real consumption and has custom programs and many functions that optimize the equipment operation. Eco Mode prevents non-necessary consumption because it regulates its operation based on the setpoint temperature.

#### Integrated drainage pump

It removes water from the condensation accumulated in the tray, even while it is in operation. Water level control and automatically activates the pump when needed.

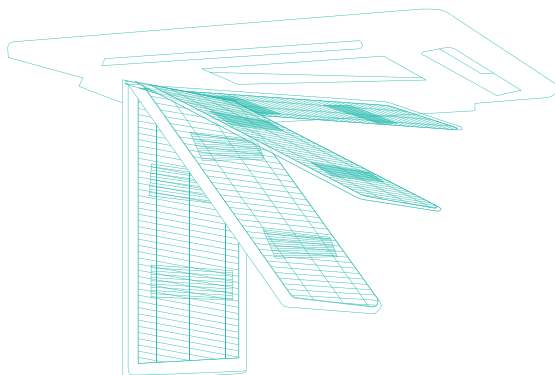

\*Depending on model.

*Ideal for facilities with a false ceiling, since its reduced dimension allows for easy installation, needing a height of only 285 mm to embed it.*



## RAI RPA CASSETTE

NAME OF THE SET		RAI 25 RPA CASSETTE	RAI 35 RPA CASSETTE	RAI 50 RPA CASSETTE
<b>INDOOR UNITS</b>		<b>RAI-25RPA</b>	<b>RAI-35RPA</b>	<b>RAI-50RPA</b>
Nominal power (min-max) <sup>(1)</sup>	Cooling	2.50 (0.90-3.00)	3.50 (0.90-4.00)	5.00 (0.90-5.20)
	Heating	3.50 (0.90-5.00)	4.80 (0.90-6.60)	6.20 (0.90-7.60)
Sound pressure level (very low - low - medium - high) <sup>(2)</sup>	Cooling	25 - 29 - 32 - 35	26 - 29 - 34 - 39	29 - 32 - 35 - 43
	Heating	27 - 30 - 33 - 36	29 - 32 - 36 - 40	30 - 32 - 36 - 43
Sound power (Eurovent data)		50	58	58
Airflow (very low - low - medium - high)	Cooling	330 - 360 - 420 - 480	390 - 420 - 510 - 570	390 - 450 - 510 - 630
	Heating	390 - 420 - 480 - 540	450 - 480 - 510 - 660	450 - 510 - 540 - 690
Pipe diameter (Liquid - Gas)	inches	1/4 - 3/8	1/4 - 3/8	1/4 - 1/2
Condensate Evacuation Diameter	mm	16	16	16
Remote control (standard)		Eco Control	Eco Control	Eco Control
<b>OUTDOOR UNITS</b>		<b>RAC-25NPA</b>	<b>RAC-35NPA</b>	<b>RAC-50NPA</b>
Absorbed nominal power (min-max)	Cooling	0.69 (0.15-1.05)	1.10 (0.15-1.28)	1.99 (0.15-2.20)
	Heating	0.94 (0.15-1.40)	1.36 (0.11-1.92)	2.16 (0.15-2.70)
EER - COP		3.60 - 3.72 (A/A)	3.18 - 3.53 (B/B)	2.51 - 2.87 (E/D)
SEER		5.70	5.80	5.20
SCOP (Average Climate Class)		3.80	3.80	3.80
Energy class <sup>(3)</sup>	Cooling	<b>A+</b>	<b>A+</b>	A
	Heating	A	A	A
Sound pressure level <sup>(4)</sup>	Cooling	46	47	50
	Heating	46	49	52
Airflow	Cooling	1620	1620	2160
	Heating	1620	1620	2160
Power supply		220-240 V, 1 Ph, 50 Hz	220-240 V, 1 Ph, 50 Hz	220-240 V, 1 Ph, 50 Hz
Pipe diameter (Liquid - Gas)	inches	1/4 - 3/8	1/4 - 3/8	1/4 - 1/2
Maximum length	m	20	20	20
Maximum height		10	10	10
Refrigerant charge	kg (m)	1.15 (20)	1.15 (20)	1.4 (20)
Refrigerant fluid		R410A	R410A	R410A
Compressor		DC Twin Rotary	DC Twin Rotary	DC Twin Rotary
<b>INDOOR UNIT PRICE (INCLUDES CONTROL)</b>				
<b>OUTDOOR UNIT PRICE</b>				
<b>PANEL PRICE</b>				
<b>PRICE OF THE SET</b>				

(1) The nominal power for cooling and heating is the combined power of the HITACHI standard split system and is based on the following conditions (ISO 5151):  
 - Cooling: indoor temperature 27°C DB, 19°C WB; outdoor temperature 35°C DB.  
 - Heating: indoor temperature 20°C DB; outdoor temperature 7°C DB, 6°C WB.  
 - Pipe length to 5 m; height at 0 m.  
 (2) The sound level measurement is performed in an anechoic camera 1 m from the discharge grille and 0.8 m below the center of the indoor unit.  
 (3) Data calculated in compliance with communication prEN14825 and 2012/c 172/01.  
 (4) The sound level measurement is performed in an anechoic camera at 1 m from the surface and at 1 m from the ground level.

Guaranteed performance

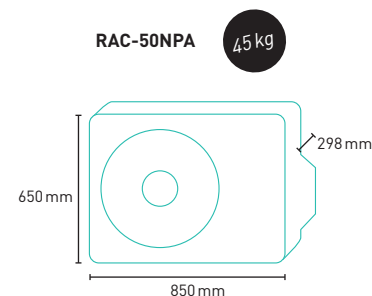
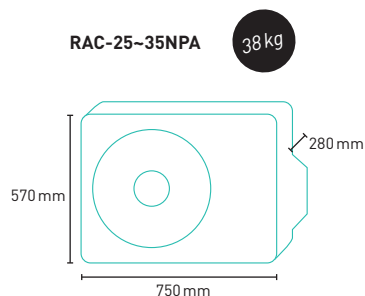
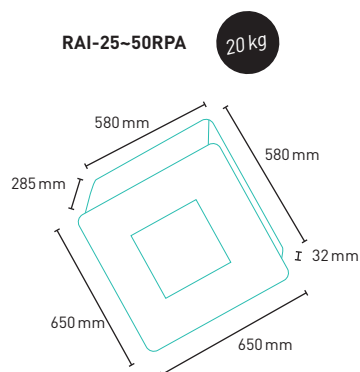
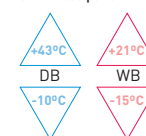

For more information about controls, see page 193.  
 Recommended prices - VAT not included, Waste Electrical and Electronic Equipment Directive (WEEE) fee not included.  
 To create the energy label visit our website [www.hitachiircon.es](http://www.hitachiircon.es) and use our Hitachi ErP Active Tool application.







# MULTIZONE

<b>MULTIZONE</b>	<b>40</b>
<hr/>	
OUTDOOR UNITS	
<b>RAM UNITS</b>	<b>43</b>
<hr/>	
INDOOR UNITS	
<b>AKEBONO WALL MOUNTED</b>	<b>44</b>
<b>PERFORMANCE WALL MOUNTED</b>	<b>44</b>
<b>AKEBONO FLOOR MOUNTED</b>	<b>45</b>
<b>DUCTS</b>	<b>45</b>
<b>CASSETTE</b>	<b>46</b>





## MULTIZONE

## MULTIZONE HITACHI RANGE

ADEQUATE CAPACITY UNITS  
THAT ARE NOT OVERSIZED FOR THE FACILITIES

Indoor units that reduce power up to 1.5\* kW.  
Ideal for small houses, reduce consumption and are not oversized for the facilities.

**More than 300 possible combinations with the range of Multizone indoor units**

RAK 15QPC



2 ROOMS



RAM-33NP2B

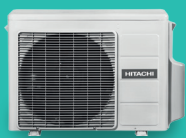

RAM-40NP2B



RAM-53NP2B

3 ROOMS



RAM-53NP3B

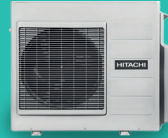

RAM-68NP3B

4 ROOMS

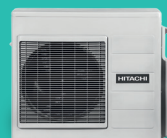

RAM-70NP4B

5 ROOMS



RAM-90NP5B

6 ROOMS



RAM-110NP6B

*Wide range.  
8 outdoor units with 3 reduced  
capacity models in high demand.  
Capacity that adapts to the needs  
of the market.*

**LOW CONSUMPTION AND HIGH PERFORMANCE UNITS**

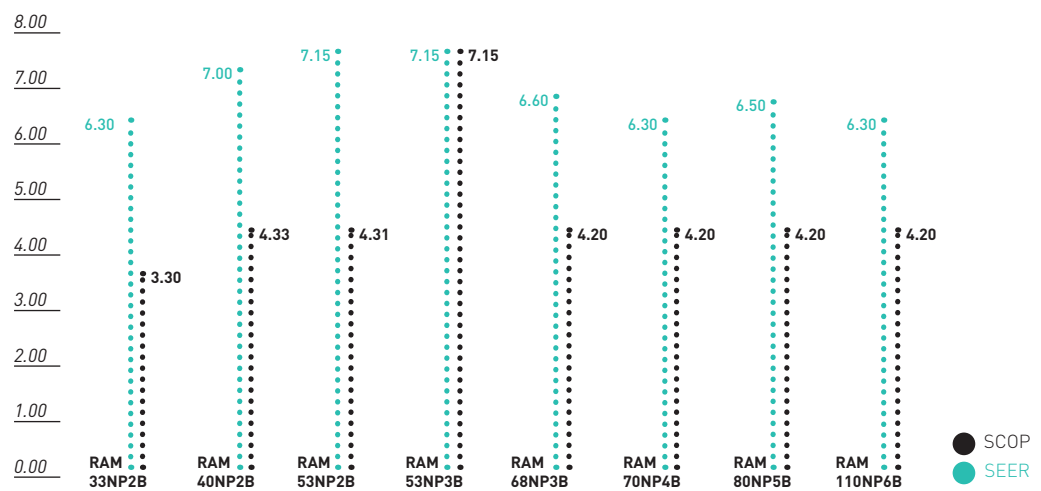

**AIR CONDITIONING SOLUTIONS THAT FIT THE CHARACTERISTICS OF EACH FACILITY**

**Long pipe distances between the outdoor unit and the indoor units.** The highest in the market.

**Set offset value from the Eco Control.**

**Operation in cold mode up to -10°C.**

**Centralized control of up to 13 indoor units with the SPX- WKT2 wired control** without the need for a distributor.

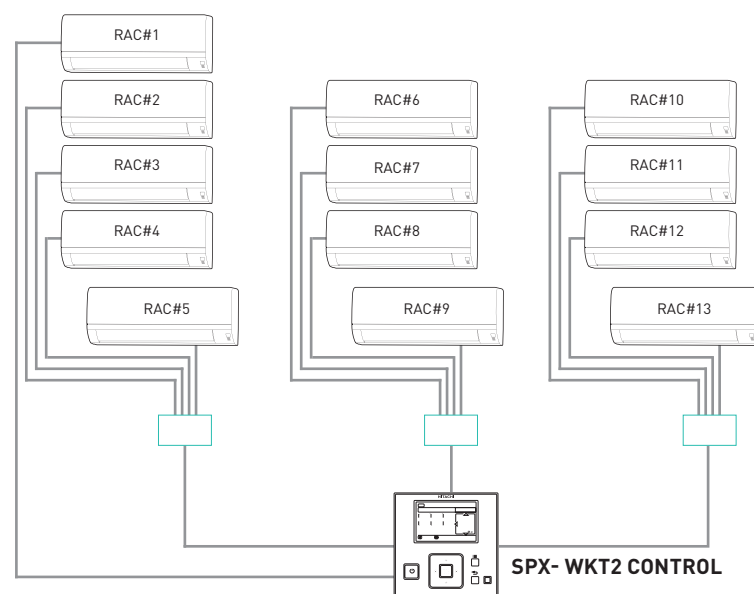

**AIR CONDITIONING SYSTEM THAT SIMPLIFIES INSTALLATION AND MAINTENANCE**

The combination with duct-type units allows the static pressure to be changed, according to the need of each installation. Lower pipe diameter, allowing for installation cost savings because smaller pipes are required. Preloaded factory refrigerant, for the most popular 2x1 models. In this way the installers do not need to add additional refrigerant which saves on time and the cost of installation. Alarm code indication, saves diagnostic time.

# MULTIZONE OUTDOOR UNITS



OUTDOOR UNITS		RAM-33NP2B	RAM-40NP2B	RAM-53NP2B	RAM-53NP3B	RAM-68NP3B	RAM-70NP4B	RAM-90NP5B	RAM-110NP6B
Minimum/maximum number of connected units		2	2	2	2/3	2/3	2/4	2/5	2/6
Nominal power (min-max)	Cooling	3.30 (1.50~3.80)	4.00 (1.50~4.20)	5.30 (1.50~6.60)	5.30 (1.50~6.60)	6.80 (2.40~8.00)	7.00 (2.40~8.80)	8.50 (1.52~9.50)	10.60 (1.50~13.20)
	Heating	4.00 (1.50~4.60)	5.20 (1.50~5.50)	6.80 (1.50~7.20)	6.80 (1.50~7.20)	8.50 (2.40~9.50)	8.50 (2.80~9.50)	11.00 (1.50~11.50)	13.60 (1.50~14.40)
Absorbed nominal power (min-max)	Cooling	0.80 (0.20~1.05)	1.05 (0.20~1.15)	1.55 (0.20~1.66)	1.55 (0.20~1.68)	2.08 (0.46~2.96)	2.11 (0.46~3.20)	2.23 (0.20~3.85)	3.20 (0.20~3.50)
	Heating	0.92 (0.20~1.50)	1.21 (0.20~1.50)	1.79 (0.20~2.01)	1.62 (0.20~1.86)	2.28 (0.43~2.60)	2.11 (0.48~3.12)	2.46 (0.20~3.85)	3.60 (0.40~3.72)
EER - COP		4.13 - 4.35	3.81 - 4.30	3.42 - 3.80	3.42 - 4.20	3.27 - 3.73	3.32 - 4.03	3.81 - 4.47	3.31 - 3.78
Energy class	Cooling	A++	A++	A++	A++	A++	A++	A++	A++
	Heating	A+	A+	A+	A+	A+	A+	A+	A+
Sound pressure level	Cooling	48	49	50	50	50	50	53	55
	Heating	50	51	51	51	53	53	56	56
Airflow	Cooling	1620	1620	2160	2160	2700	2700	3900	4320
	Heating	1620	1620	2160	2160	2700	2700	3900	4320
Power supply		220~240 V, 1 Ph, 50~60 Hz	220~240 V, 1 Ph, 50~60 Hz	220~240 V, 1 Ph, 50~60 Hz	220~240 V, 1 Ph, 50~60 Hz	220~240 V, 1 Ph, 50~60 Hz	220~240 V, 1 Ph, 50~60 Hz	220~240 V, 1 Ph, 50~60 Hz	220~240 V, 1 Ph, 50~60 Hz
Pipe diameter	Liquid	1/4 x 2	1/4 x 2	1/4 x 2	1/4 x 3	1/4 x 3	1/4 x 4	1/4 x 5	(1/4 x 3) x 2
	Gas	3/8 x 2	3/8 x 2	3/8 x 2	3/8 x 3	3/8 x 3	(3/8 x 3) + (1/2 x 1)	(3/8 x 3) + (1/2 x 2)	(3/8 x 3) x 2
Maximum length		20	35	35	45	60	60	75	45 per circuit
Maximum height		10	20	20	20	20	20	20	20 per circuit
Refrigerant charge		1.03	1.45	1.90	1.90	2.30	2.30	2.70	1.65
Additional refrigerant charge		20	35	35	35/20	30/20	30/20	30/15	35/20
Refrigerant fluid		R410A	R410A	R410A	R410A	R410A	R410A	R410A	R410A
Compressor		Rotating	DC Twin Rotary	DC Twin Rotary	DC Twin Rotary	DC Twin Rotary	DC Twin Rotary	DC Twin Rotary	DC Twin Rotary
<b>PRICE</b>									

[1] The nominal power for cooling and heating is the combined power of the HITACHI standard split system and is based on the following conditions (ISO 5151):  
 - Cooling: indoor temperature 27°C DB, 19°C WB; outdoor temperature 35°C DB.  
 - Heating: indoor temperature 20°C DB; outdoor temperature 7°C DB, 6°C WB.  
 - Pipe length to 5 m; height at 0 m.

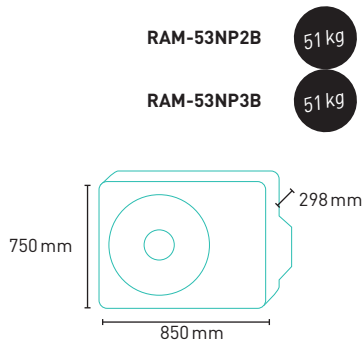
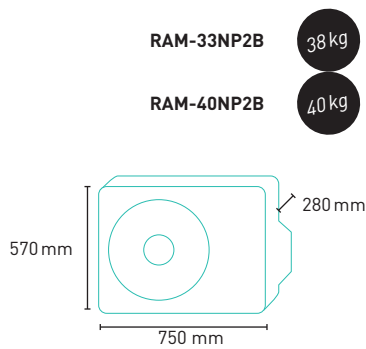

Guaranteed performance

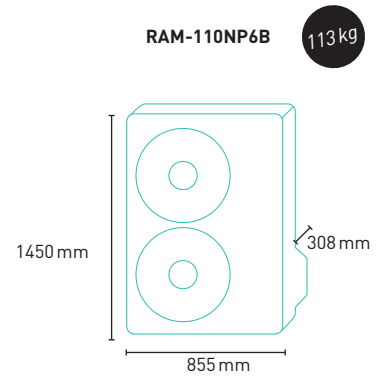
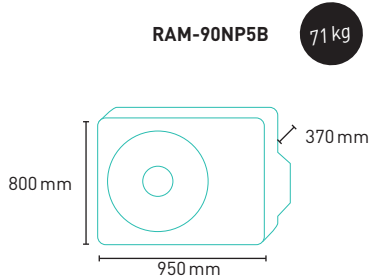
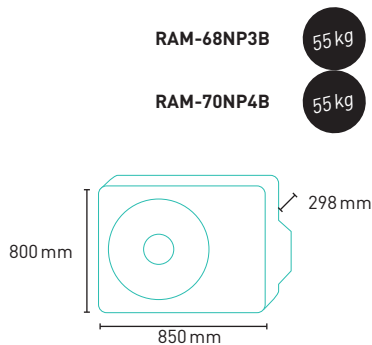
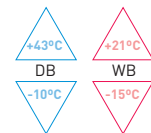

**MULTIZONE**  
INDOOR UNITS



**AKEBONO WALL MOUNTED**



INDOOR UNITS		RAK-18QXB	RAK-25RXB	RAK-35RXB	RAK-50RXB
Nominal power (min-max) <sup>(1)</sup>	Cooling	1.80 (1.00-2.50)	2.50 (0.90-3.10)	3.50 (0.90-4.00)	5.00 (1.90-5.20)
	Heating	2.50 (1.10-3.20)	3.20 (0.90-4.20)	4.00 (0.90-4.80)	5.80 (2.20-7.00)
Sound pressure level (very low - low - medium - high) <sup>(2)</sup>	Cooling	20 - 25 - 30 - 36	20 - 26 - 32 - 40	22 - 29 - 35 - 42	25 - 31 - 39 - 47
	Heating	20 - 26 - 32 - 38	20 - 27 - 33 - 40	22 - 30 - 35 - 42	25 - 31 - 39 - 48
Sound power (Eurovent data)		49	55	60	60
Airflow (very low - low - medium - high)	Cooling	300 - 330 - 430 - 500	300 - 330 - 510 - 560	320 - 340 - 430 - 580	350 - 400 - 580 - 720
	Heating	310 - 360 - 480 - 600	290 - 370 - 560 - 610	310 - 360 - 480 - 630	350 - 420 - 620 - 800
Pipe diameter (Liquid - Gas)	inches	1/4 - 3/8	1/4 - 3/8	1/4 - 3/8	1/4 - 1/2
Condensate Evacuation Diameter	mm	16	16	16	16
Remote control (standard)		Eco Control	Eco Control	Eco Control	Eco Control
<b>PRICE</b>					

(1) The nominal power for cooling and heating is the combined power of the HITACHI standard split system and is based on the following conditions (ISO 5151):  
 - Cooling: indoor temperature 27°C DB, 19°C WB; outdoor temperature 35°C DB.  
 - Heating: indoor temperature 20°C DB; outdoor temperature 7°C DB, 6°C WB.  
 - Pipe length to 5 m; height at 0 m.

(2) The sound level measurement is performed in an anechoic camera 1 m from the discharge grille and 0.8 m below the center of the indoor unit.

**HITACHI exclusivity:** Size 18 reduces power from 1.80 kW to 1.20 kW. The ideal solution for small surfaces.  
**Very quiet units:** 20 dB(A) depending on model.  
**Removable front.**

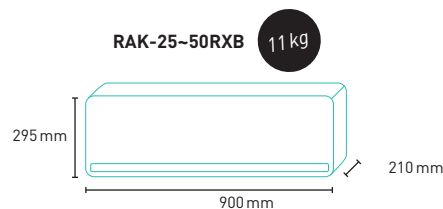

**PERFORMANCE WALL MOUNTED**



INDOOR UNITS		RAK-15QPB	RAK-18RPC	RAK-25RPC	RAK-35RPC	RAK-50RPC
Nominal power (min-max) <sup>(1)</sup>	Cooling	1.50 (0.90-2.00)	2.00 (0.90-2.50)	2.50 (0.90-3.10)	3.50 (0.90-4.00)	5.00 (1.90-5.20)
	Heating	1.50 (1.00-2.50)	2.50 (0.90-3.20)	3.40 (0.90-4.40)	4.20 (0.90-5.00)	6.00 (2.20-7.30)
Sound pressure level (very low - low - medium - high) <sup>(2)</sup>	Cooling	20 - 24 - 30 - 34	21 - 24 - 33 - 37	22 - 24 - 33 - 40	25 - 26 - 36 - 43	25 - 28 - 39 - 46
	Heating	20 - 24 - 32 - 35	19 - 22 - 33 - 38	20 - 23 - 34 - 41	26 - 27 - 36 - 44	27 - 31 - 39 - 46
Sound power (Eurovent data)		47	51	54	57	60
Airflow (very low - low - medium - high)	Cooling	312 - 350 - 400 - 420	312 - 350 - 400 - 440	333 - 370 - 430 - 510	353 - 420 - 485 - 680	353 - 410 - 540 - 750
	Heating	312 - 350 - 420 - 480	312 - 350 - 420 - 480	333 - 400 - 500 - 570	363 - 480 - 570 - 780	380 - 500 - 610 - 820
Pipe diameter (Liquid - Gas)	inches	1/4 - 3/8	1/4 - 3/8	1/4 - 3/8	1/4 - 3/8	1/4 - 1/2
Condensate Evacuation Diameter	mm	16	16	16	16	16
Remote control (standard)		Eco Control	Eco Control	Eco Control	Eco Control	Eco Control
<b>PRICE</b>						

(1) The nominal power for cooling and heating is the combined power of the HITACHI standard split system and is based on the following conditions (ISO 5151):  
 - Cooling: indoor temperature 27°C DB, 19°C WB; outdoor temperature 35°C DB.  
 - Heating: indoor temperature 20°C DB; outdoor temperature 7°C DB, 6°C WB.  
 - Pipe length to 5 m; height at 0 m.

(2) The sound level measurement is performed in an anechoic camera 1 m from the discharge grille and 0.8 m below the center of the indoor unit.

**Hitachi exclusivity:** Size 15 reduces power from 1.50 kW to 1.00 kW. The ideal solution for small surfaces.

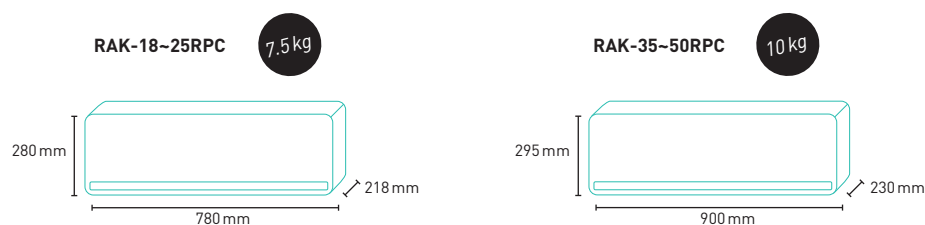

For more information about controls, see page 193.  
 Recommended prices - VAT not included, Waste Electrical and Electronic Equipment Directive (WEEE) fee not included.  
 To create the energy label visit our website [www.hitachiircon.es](http://www.hitachiircon.es) and use our Hitachi ErP Active Tool application.



## MULTIZONE INDOOR UNITS



### AKEBONO FLOOR MOUNTED

INDOOR UNITS			RAF-25RXB	RAF-35RXB	RAF-50RXB
Nominal power (min-max) <sup>(1)</sup>	Cooling	kW	2.50 (0.90-3.10)	3.50 (0.90-4.00)	5.00 (0.90-5.20)
	Heating		3.40 (0.90-4.40)	4.50 (0.90-5.00)	6.00 (0.90-8.10)
Sound pressure level (very low - low - medium - high) <sup>(2)</sup>	Cooling	dB(A)	20 - 26 - 31 - 38	20 - 26 - 31 - 39	22 - 29 - 36 - 43
	Heating		20 - 26 - 31 - 38	20 - 26 - 31 - 39	22 - 29 - 36 - 44
Sound power (Eurovent data)			55	56	59
Airflow (very low - low - medium - high)	Cooling	m <sup>3</sup> /h	270 - 390 - 510 - 630	270 - 390 - 510 - 660	300 - 450 - 540 - 720
	Heating		300 - 420 - 540 - 660	300 - 420 - 540 - 690	330 - 480 - 570 - 750
Pipe diameter (Liquid - Gas)			1/4 - 3/8	1/4 - 3/8	1/4 - 1/2
Condensate Evacuation Diameter			16	16	16
Remote control (standard)			Eco Control	Eco Control	Eco Control
<b>PRICE</b>					

(1) The nominal power for cooling and heating is the combined power of the HITACHI standard split system and is based on the following conditions (ISO 5151):  
 - Cooling: indoor temperature 27°C DB, 19°C WB; outdoor temperature 35°C DB.  
 - Heating: indoor temperature 20°C DB; outdoor temperature 7°C DB, 6°C WB.  
 - Pipe length to 5 m; height at 0 m.

(2) The sound level measurement is performed in an anechoic camera 1 m from the discharge grille and 0.8 m below the center of the indoor unit.

#### High performance filtration

##### Nano pre-filters

**Lower air exit** for greater heating comfort.

**Adjustable base** to fit all decorations.



RAF-25-50RXB 15 kg

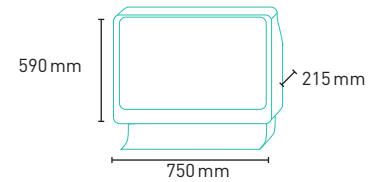

## DUCTS

INDOOR UNITS			RAD-18QPB	RAD-25QPB	RAD-35QPB	RAD-50QPB
Nominal power (min-max) <sup>(1)</sup>	Cooling	kW	1.80 (0.90-2.50)	2.50 (0.90-3.00)	3.50 (0.90-4.00)	5.00 (0.90-5.60)
	Heating		2.50 (0.90-3.20)	3.50 (0.90-5.50)	4.80 (0.90-6.60)	6.00 (0.90-7.50)
Sound pressure level (very low - low - medium - high) <sup>(2)</sup>	Cooling	dB(A)	30 - 33 - 37 - 41	30 - 33 - 37 - 41	30 - 33 - 37 - 41	31 - 35 - 39 - 43
	Heating		31 - 34 - 38 - 42	30 - 34 - 38 - 42	30 - 34 - 38 - 42	31 - 35 - 39 - 43
Sound power (Eurovent data)			57	57	57	58
Airflow (very low - low - medium - high)	Cooling	m <sup>3</sup> /h	400 - 480 - 560 - 600	400 - 480 - 560 - 600	400 - 480 - 570 - 660	400 - 480 - 570 - 660
	Heating		450 - 520 - 590 - 650	450 - 520 - 590 - 650	440 - 510 - 600 - 720	440 - 510 - 600 - 720
Pipe diameter (Liquid / Gas)			1/4 - 3/8	1/4 - 3/8	1/4 - 3/8	1/4 - 1/2
Condensate Evacuation Diameter			16	16	16	16
Static pressure switch on High (low, medium, high)	Pa	(m3/h)	C [42 (242)/49(274)/51(291)]	C [42 (242)/49(274)/51(291)]	C [44 (243)/50(279)/58(323)]	C [44 (243)/50(279)/58(323)]
			H [46 (266)/52(293)/57(314)]	H [46 (266)/52(293)/57(314)]	H [51 (259)/58(289)/69(340)]	H [51 (259)/58(289)/69(340)]
Remote control (not standard)			Wired	Wired	Wired	Wired
<b>PRICE</b>						
<b>SPX-WKT2 WIRED CONTROL PRICE</b>						
<b>ECO CONTROL REMOTE CONTROL PRICE</b>						

(1) The nominal power for cooling and heating is the combined power of the HITACHI standard split system and is based on the following conditions (ISO 5151):  
 - Cooling: indoor temperature 27°C DB, 19°C WB; outdoor temperature 35°C DB.  
 - Heating: indoor temperature 20°C DB; outdoor temperature 7°C DB, 6°C WB.  
 - Pipe length to 5 m; height at 0 m.

(2) The sound level measurement is performed in an anechoic camera 1 m from the discharge grille and 0.8 m below the center of the indoor unit.

#### Compatible with Eco Control (SPX-

**RCKA). Not included as standard.**

**Discreet installation and quiet operation.**

**Extendible ducts up to 4 m.**

**Air entrance of your choice** from behind or below.

**Integrated drainage pump, mobile electrical box, integrated filter.**

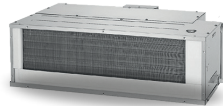

RAD-25-50RPA 19 kg

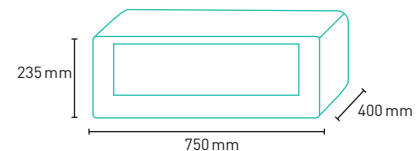



## CASSETTE

INDOOR UNITS			RAI-25QPB	RAI-35QPB	RAI-50QPB
Nominal power (min-max) <sup>(1)</sup>	Cooling	kW	2.50 (0.90-3.00)	3.50 (0.90-4.00)	5.00 (0.90-5.20)
	Heating		3.50 (0.90-5.00)	4.80 (0.90-6.60)	6.20 (0.90-7.60)
Sound pressure level (very low - low - medium - high) <sup>(2)</sup>	Cooling	dB(A)	28 - 31 - 34 - 37	30 - 34 - 38 - 42	32 - 36 - 40 - 44
	Heating		29 - 32 - 35 - 38	30 - 35 - 39 - 43	32 - 36 - 40 - 44
Sound power (Eurovent data)			50	58	58
Airflow (very low - low - medium - high)	Cooling	m³/h	330 - 360 - 420 - 510	390 - 420 - 510 - 650	390 - 450 - 510 - 720
	Heating		390 - 420 - 480 - 550	450 - 480 - 510 - 660	450 - 510 - 540 - 720
Pipe diameter (Liquid - Gas)			1/4 - 3/8	1/4 - 3/8	1/4 - 1/2
Condensate Evacuation Diameter			16	16	16
Remote control (standard)			Eco Control	Eco Control	Eco Control
<b>PRICE</b>					
<b>PANEL COST</b>					

(1) The nominal power for cooling and heating is the combined power of the HITACHI standard split system and is based on the following conditions (ISO 5151):  
 - Cooling: indoor temperature 27°C DB, 19°C WB; outdoor temperature 35°C DB.  
 - Heating: indoor temperature 20°C DB; outdoor temperature 7°C DB, 6°C WB.  
 - Pipe length to 5 m; height at 0 m.  
 (2) The sound level measurement is performed in an anechoic camera 1 m from the discharge grille and 0.8 m below the center of the indoor unit.

- Up to 4-way air flow, of your choice.
- Automatic swing grille.
- Integrated drainage pump.
- One touch panel for easy cleaning.

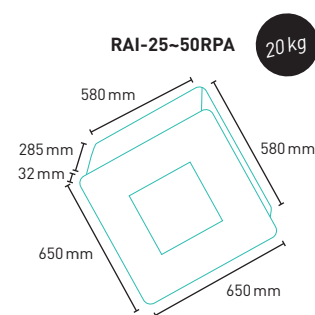



## MULTIZONE COMBINATIONS

# RAM-33NP2B

POSSIBLE COMBINATIONS OF INDOOR UNITS	COOLING MODE					HEATING MODE					
	Unit power (kW)	Total power (kW)	Total Abs. power (W)	EER	Energy class	Unit power (kW)	Total power (kW)	Total Abs. power (W)	COP	Energy class	
2 UNITS	15 + 15	1.50 + 1.50	3.00 (1.50-3.50)	810 (200-930)	3.70	A	2.00 + 2.00	4.00 (1.50-4.60)	950 (200-1250)	4.21	A
	15 + 18	1.50 + 1.80	3.30 (1.50-3.80)	800 (200-930)	4.13	A	1.78 + 2.22	4.00 (1.50-4.60)	950 (200-1250)	4.21	A
	15 + 25	1.24 + 2.06	3.30 (1.50-3.80)	800 (200-930)	4.13	A	1.36 + 2.64	4.00 (1.50-4.60)	950 (200-1250)	4.21	A
	18 + 18	1.65 + 1.65	3.30 (1.50-3.80)	800 (200-1050)	4.13	A	2.00 + 2.00	4.00 (1.50-4.60)	950 (200-1500)	4.21	A
	18 + 25	1.38 + 1.92	3.30 (1.50-3.80)	800 (200-1050)	4.13	A	1.56 + 2.44	4.00 (1.50-4.60)	950 (200-1500)	4.21	A
	25 + 25	1.65 + 1.65	3.30 (1.50-3.80)	800 (200-1050)	4.13	A	2.00 + 2.00	4.00 (1.50-4.60)	920 (200-1500)	4.35	A

### ▲ RAM-33NP2B FRIGORIFIC LENGTHS

(L1+L2)= max 20 m  
 The minimum pipe length for each indoor unit is 3 m.  
 The maximum pipe length for the indoor unit is 20 m.  
 The height difference between the indoor units must not exceed 5 m.  
 Maximum height 10 m.  
 No additional load required

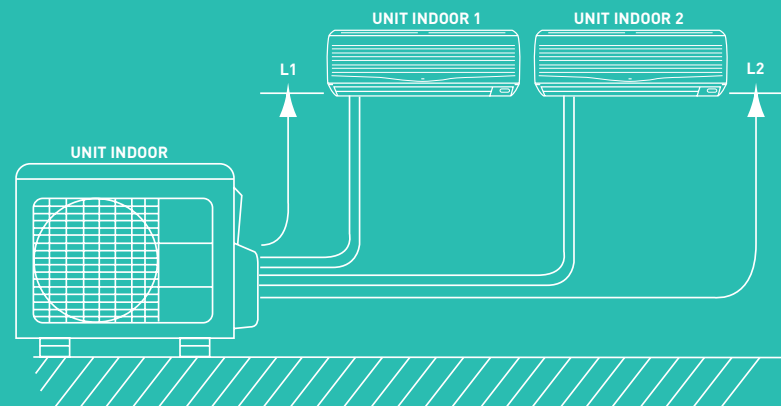

Hotel Tamarit  
 RPC Performance Range





**MULTIZONE  
COMBINATIONS**

**RAM-40NP2B**

POSSIBLE COMBINATIONS OF INDOOR UNITS	COOLING MODE					HEATING MODE				
	Unit power (kW)	Total power (kW)	Total Abs. power (W)	EER	Energy class	Unit power (kW)	Total power (kW)	Total Abs. power (W)	COP	Energy class
15 + 15	1.50 + 1.50	3.00 (1.50~2.80)	820 (200~780)	3.66	A	2.00 + 2.00	4.00 (1.50~4.60)	1020 (200~950)	3.92	A
15 + 18	1.50 + 1.80	3.30 (1.50~3.50)	870 (200~930)	3.79	A	2.00 + 2.50	4.50 (1.50~5.00)	1120 (200~1020)	4.02	A
15 + 25	1.50 + 2.50	4.00 (1.50~4.00)	1050 (200~1150)	3.81	A	1.89 + 3.31	5.20 (1.50~5.50)	1280 (200~1500)	4.06	A
15 + 35	1.20 + 2.80	4.00 (1.50~4.20)	1050 (200~1150)	3.81	A	1.53 + 3.67	5.20 (1.50~5.50)	1250 (200~1500)	4.16	A
18 + 18	1.80 + 1.80	3.60 (1.50~4.00)	968 (200~1050)	3.72	A	2.50 + 2.50	5.00 (1.50~5.00)	1230 (200~1500)	4.07	A
18 + 25	1.67 + 2.33	4.00 (1.50~4.20)	1050 (200~1150)	3.81	A	2.17 + 3.03	5.20 (1.50~5.50)	1250 (200~1500)	4.16	A
18 + 35	1.36 + 2.64	4.00 (1.50~4.20)	1050 (200~1150)	3.81	A	1.78 + 3.42	5.20 (1.50~5.50)	1250 (200~1500)	4.16	A
25 + 25	2.00 + 2.00	4.00 (1.50~4.20)	1050 (200~1150)	3.81	A	2.60 + 2.60	5.20 (1.50~5.50)	1250 (200~1500)	4.16	A
25 + 35	1.67 + 2.33	4.00 (1.50~4.20)	1050 (200~1150)	3.81	A	2.19 + 3.01	5.20 (1.50~5.50)	1210 (200~1500)	4.30	A

**RAM-40NP2B FRIGORIFIC LENGTHS**

(L1+L2)= max 35 m.  
 The minimum pipe length for each indoor unit is 3 m.  
 The maximum pipe length for the indoor unit is 25m.  
 The height difference between the indoor units must not exceed 5 m.  
 Maximum height 20 m.  
 No additional load required.

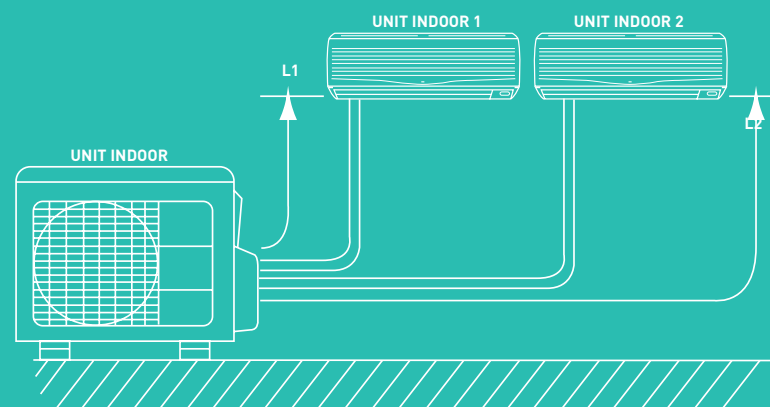

## MULTIZONE COMBINATIONS

# RAM-53NP2B

POSSIBLE COMBINATIONS OF INDOOR UNITS	COOLING MODE					HEATING MODE				
	Unit power (kW)	Total power (kW)	Total Abs. power (W)	EER	Energy class	Unit power (kW)	Total power (kW)	Total Abs. power (W)	COP	Energy class
15 + 15	1.50 + 1.50	3.00 (1.50~3.90)	920 (200~1000)	3.26	A	2.00 + 2.00	4.00 (1.50~4.70)	1060 (200~1380)	3.77	A
15 + 18	1.50 + 1.80	3.30 (1.50~3.90)	1020 (200~1300)	3.24	A	2.00 + 2.50	4.50 (1.50~5.20)	1250 (200~1870)	3.60	A
15 + 25	1.50 + 2.50	4.00 (1.50~4.50)	1180 (200~1250)	3.39	A	2.00 + 3.90	5.90 (1.50~6.50)	1620 (200~2010)	3.64	A
15 + 35	1.50 + 3.50	5.00 (1.50~5.90)	1480 (200~1660)	3.38	A	2.00 + 4.80	6.80 (1.50~7.20)	1820 (200~2010)	3.74	A
15 + 50	1.22 + 4.08	5.30 (1.50~5.90)	1550 (200~1660)	3.42	A	1.60 + 5.20	6.80 (1.50~7.20)	1820 (200~2010)	3.74	A
18 + 18	1.80 + 1.80	3.60 (1.50~4.00)	1080 (200~1300)	3.33	A	2.50 + 2.50	5.00 (1.50~5.20)	1290 (200~1550)	3.88	A
18 + 25	1.80 + 2.50	4.30 (1.50~4.60)	1280 (200~1450)	3.36	A	2.50 + 3.90	6.40 (1.50~6.30)	1700 (200~1920)	3.76	A
18 + 35	1.80 + 3.50	5.30 (1.50~5.60)	1550 (200~1660)	3.42	A	2.31 + 4.49	6.80 (1.50~7.20)	1850 (200~2010)	3.68	A
18 + 50	1.40 + 3.90	5.30 (1.50~5.90)	1550 (200~1660)	3.42	A	1.80 + 5.00	6.80 (1.50~7.20)	1820 (200~2010)	3.74	A
25 + 25	2.50 + 2.50	5.00 (1.50~5.60)	1470 (200~1660)	3.40	A	3.40 + 3.40	6.80 (1.50~7.20)	1820 (200~2010)	3.74	A
25 + 35	2.21 + 3.09	5.30 (1.50~5.70)	1550 (200~1660)	3.42	A	2.83 + 3.97	6.80 (1.50~7.20)	1820 (200~2010)	3.74	A
35 + 35	2.65 + 2.65	5.30 (1.50~5.90)	1550 (200~1660)	3.42	A	3.40 + 3.40	6.80 (1.50~7.20)	1790 (200~2010)	3.80	A
25 + 50	1.77 + 3.53	5.30 (1.50~5.90)	1550 (200~1660)	3.42	A	2.27 + 4.53	6.80 (1.50~7.20)	1790 (200~2010)	3.80	A
35 + 50	2.18 + 3.12	5.30 (1.50~6.60)	1550 (200~1660)	3.42	A	2.80 + 4.00	6.80 (1.50~7.20)	1790 (200~2010)	3.80	A

(1) This combination needs to add a cooling adapter to go from 0.95 to 1.27 when installing the size 50 indoor unit.

### ▲ RAM-53NP2B FRIGORIFIC LENGTHS

(L1+L2)= max 35 m.  
The minimum pipe length for each indoor unit is 3 m.  
The maximum pipe length for the indoor unit is 25m.  
The height difference between the indoor units  
must not exceed 5 m.  
Maximum height 20m.  
No additional load required.

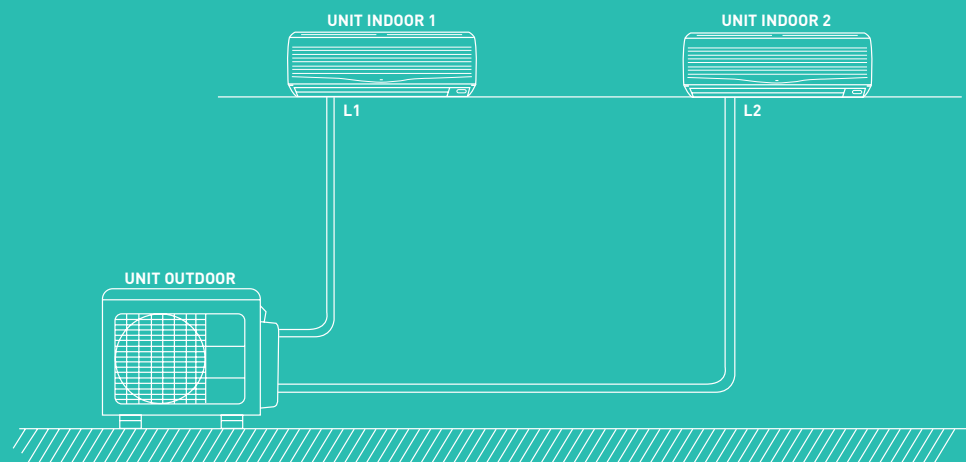



MULTIZONE  
COMBINATIONS

# RAM-53NP3B

POSSIBLE COMBINATIONS OF INDOOR UNITS	COOLING MODE					HEATING MODE					
	Unit power (kW)	Total power (kW)	Total Abs. power (W)	EER	Energy class	Unit power (kW)	Total power (kW)	Total Abs. power (W)	COP	Energy class	
2 UNITS	15 + 15	1.50 + 1.50	3.00 (1.50-3.90)	920 (200-1000)	3.26	A	2.00 + 2.00	4.00 (1.50-4.70)	1060 (200-1380)	3.77	A
	15 + 18	1.50 + 1.80	3.30 (1.50-3.90)	1020 (200-1300)	3.24	A	2.00 + 2.50	4.50 (1.50-5.20)	1250 (200-1870)	3.60	A
	15 + 25	1.50 + 2.50	4.00 (1.50-4.50)	1180 (200-1250)	3.39	A	2.00 + 3.90	5.90 (1.50-6.50)	1620 (200-2010)	3.64	A
	15 + 35	1.50 + 3.50	5.00 (1.50-5.90)	1480 (200-1660)	3.38	A	2.00 + 4.80	6.80 (1.50-7.20)	1820 (200-2010)	3.74	A
	15 + 50	1.22 + 4.08	5.30 (1.50-5.90)	1550 (200-1660)	3.42	A	1.60 + 5.20	6.80 (1.50-7.20)	1820 (200-2010)	3.74	A
	18 + 18	1.80 + 1.80	3.60 (1.50-4.00)	1080 (200-1300)	3.33	A	2.50 + 2.50	5.00 (1.50-5.20)	1290 (200-1550)	3.88	A
	18 + 25	1.80 + 2.50	4.30 (1.50-4.60)	1280 (200-1450)	3.36	A	2.50 + 3.90	6.40 (1.50-6.30)	1700 (200-1920)	3.76	A
	18 + 35	1.80 + 3.50	5.30 (1.50-5.60)	1550 (200-1660)	3.42	A	2.31 + 4.49	6.80 (1.50-7.20)	1850 (200-2010)	3.68	A
	18 + 50	1.40 + 3.90	5.30 (1.50-5.90)	1550 (200-1660)	3.42	A	1.80 + 5.00	6.80 (1.50-7.20)	1820 (200-2010)	3.74	A
	25 + 25	2.50 + 2.50	5.00 (1.50-5.60)	1470 (200-1660)	3.40	A	3.40 + 3.40	6.80 (1.50-7.20)	1820 (200-2010)	3.74	A
	25 + 35	2.21 + 3.09	5.30 (1.50-5.70)	1550 (200-1660)	3.42	A	2.83 + 3.97	6.80 (1.50-7.20)	1820 (200-2010)	3.74	A
	35 + 35	2.65 + 2.65	5.30 (1.50-5.90)	1550 (200-1660)	3.42	A	3.40 + 3.40	6.80 (1.50-7.20)	1790 (200-2010)	3.80	A
	25 + 50	1.77 + 3.53	5.30 (1.50-5.90)	1550 (200-1660)	3.42	A	2.27 + 4.53	6.80 (1.50-7.20)	1790 (200-2010)	3.80	A
	35 + 50	2.18 + 3.12	5.30 (1.50-6.60)	1550 (200-1660)	3.42	A	2.80 + 4.00	6.80 (1.50-7.20)	1790 (200-2010)	3.80	A
3 UNITS	15 + 15 + 15	1.50 + 1.50 + 1.50	4.50 (1.50-5.00)	1320 (200-1680)	3.41	A	2.00 + 2.00 + 2.00	6.00 (1.50-6.20)	1580 (200-1550)	3.80	A
	15 + 15 + 18	1.50 + 1.50 + 1.80	4.80 (1.50-6.00)	1420 (200-1680)	3.38	A	2.00 + 2.00 + 2.50	6.50 (1.50-6.60)	1620 (200-1760)	4.01	A
	15 + 15 + 25	1.45 + 1.45 + 2.41	5.30 (1.50-6.00)	1550 (200-1660)	3.42	A	1.72 + 1.72 + 3.36	6.80 (1.50-7.20)	1680 (200-1860)	4.05	A
	15 + 15 + 35	1.22 + 1.22 + 2.85	5.30 (1.50-6.00)	1550 (200-1680)	3.42	A	1.55 + 1.55 + 3.71	6.80 (1.50-7.20)	1680 (200-1860)	4.05	A
	15 + 15 + 50	0.99 + 0.99 + 3.31	5.30 (1.50-6.00)	1550 (200-1680)	3.42	A	1.30 + 1.30 + 4.21	6.80 (1.50-7.20)	1680 (200-1860)	4.05	A
	15 + 18 + 18	1.50 + 1.80 + 1.80	5.10 (1.50-6.00)	1500 (200-1660)	3.40	A	1.94 + 2.43 + 2.43	6.80 (1.50-7.20)	1680 (200-1860)	4.05	A
	15 + 18 + 25	1.37 + 1.64 + 2.28	5.30 (1.50-6.00)	1550 (200-1680)	3.42	A	1.62 + 2.02 + 3.16	6.80 (1.50-7.20)	1680 (200-1860)	4.05	A
	15 + 18 + 35	1.17 + 1.40 + 2.73	5.30 (1.50-6.00)	1550 (200-1680)	3.42	A	1.46 + 1.83 + 3.51	6.80 (1.50-7.20)	1680 (200-1860)	4.05	A
	15 + 18 + 50	0.96 + 1.15 + 3.19	5.30 (1.50-6.00)	1550 (200-1680)	3.42	A	1.24 + 1.55 + 4.02	6.80 (1.50-7.20)	1680 (200-1860)	4.05	A
	15 + 25 + 25	1.22 + 2.04 + 2.04	5.30 (1.50-6.00)	1550 (200-1680)	3.42	A	1.39 + 2.71 + 2.71	6.80 (1.50-7.20)	1680 (200-1860)	4.05	A
	15 + 25 + 35	1.06 + 1.77 + 2.47	5.30 (1.50-6.00)	1550 (200-1680)	3.42	A	1.27 + 2.48 + 3.05	6.80 (1.50-7.20)	1680 (200-1860)	4.05	A
	15 + 35 + 35	0.94 + 2.18 + 2.18	5.30 (1.50-6.00)	1550 (200-1680)	3.42	A	1.17 + 2.81 + 2.81	6.80 (1.50-7.20)	1680 (200-1860)	4.05	A
	18 + 18 + 18	1.77 + 1.77 + 1.77	5.30 (1.50-6.00)	1550 (200-1680)	3.42	A	2.27 + 2.27 + 2.27	6.80 (1.50-7.20)	1680 (200-1860)	4.05	A
	18 + 18 + 25	1.56 + 1.56 + 2.17	5.30 (1.50-6.40)	1550 (200-1680)	3.42	A	2.01 + 2.01 + 2.79	6.80 (1.50-7.20)	1680 (200-1860)	4.05	A
	18 + 18 + 35	1.34 + 1.34 + 2.61	5.30 (1.50-6.60)	1550 (200-1680)	3.42	A	1.72 + 1.72 + 3.35	6.80 (1.50-7.20)	1680 (200-1860)	4.05	A
	18 + 18 + 50	1.11 + 1.11 + 3.08	5.30 (1.50-6.60)	1550 (200-1680)	3.42	A	1.42 + 1.42 + 3.95	6.80 (1.50-7.20)	1680 (200-1860)	4.05	A
	18 + 25 + 25	1.40 + 1.95 + 1.95	5.30 (1.50-6.60)	1550 (200-1680)	3.42	A	1.80 + 2.50 + 2.50	6.80 (1.50-7.20)	1680 (200-1860)	4.05	A
	18 + 25 + 35	1.22 + 1.70 + 2.38	5.30 (1.50-6.60)	1550 (200-1680)	3.42	A	1.57 + 2.18 + 3.05	6.80 (1.50-7.20)	1680 (200-1860)	4.05	A
	18 + 35 + 35	1.08 + 2.11 + 2.11	5.30 (1.50-6.60)	1550 (200-1680)	3.42	A	1.40 + 2.70 + 2.70	6.80 (1.50-7.20)	1680 (200-1860)	4.05	A
	25 + 25 + 25	1.77 + 1.77 + 1.77	5.30 (1.50-6.60)	1550 (200-1680)	3.42	A	2.27 + 2.27 + 2.27	6.80 (1.50-7.20)	1680 (200-1860)	4.05	A
25 + 25 + 35	1.56 + 1.56 + 2.18	5.30 (1.50-6.60)	1550 (200-1680)	3.42	A	2.00 + 2.00 + 2.80	6.80 (1.50-7.20)	1620 (200-1860)	4.20	A	

[1] This combination needs to add a cooling adapter to go from 0.95 to 1.27 when installing the size 50 indoor unit.

## RAM-53NP3B FRIGORIFIC LENGTHS

(L1+L2+L3)= max 45 m. However, L1+L2= max 35 m.  
 The minimum pipe length for each indoor unit is 3 m.  
 The maximum pipe length for the indoor unit is 25m.  
 The height difference between the indoor units must not exceed 5 m.  
 Maximum height 20m.  
 Preload for 30 m.  
 Provide 20 g/m additional beyond 30 m.  
 No additional load required.

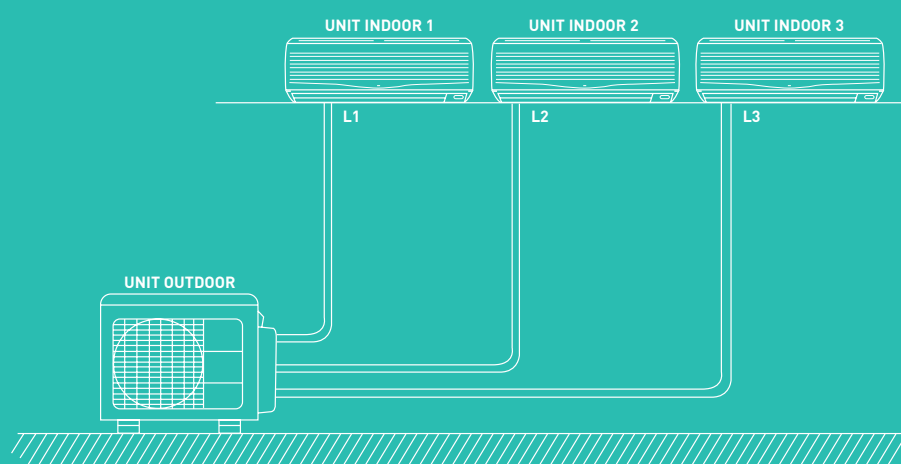

## MULTIZONE COMBINATIONS

# RAM-68NP3B

POSSIBLE COMBINATIONS OF INDOOR UNITS	COOLING MODE					HEATING MODE					
	Unit power (kW)	Total power (kW)	Total Abs. power (W)	EER	Energy class	Unit power (kW)	Total power (kW)	Total Abs. power (W)	COP	Energy class	
2 UNITS	15 + 15	1.50 + 1.50	3.00 (1.50-2.80)	870 (380-980)	3.45	A	2.00 + 2.00	4.00 (2.20-4.70)	1080 (200-1100)	3.70	A
	15 + 18	1.50 + 1.80	3.30 (1.50-3.50)	950 (380-1000)	3.47	A	2.00 + 2.50	4.50 (2.20-5.20)	1200 (200-1300)	3.75	A
	15 + 25	1.50 + 2.50	4.00 (1.50-4.00)	1150 (380-1300)	3.48	A	2.00 + 3.40	5.40 (2.20-6.40)	1450 (200-1780)	3.72	A
	15 + 35	1.50 + 3.50	5.00 (1.50-5.20)	1450 (380-1450)	3.45	A	2.00 + 4.30	6.30 (2.20-7.20)	1660 (200-2010)	3.80	A
	15 + 50	1.50 + 5.00	6.50 (1.50-5.90)	1950 (380-2380)	3.33	A	2.00 + 6.50	8.50 (2.20-7.20)	2200 (390-3120)	3.86	A
	18 + 18	1.80 + 1.80	3.60 (2.00-4.00)	1020 (380-1020)	3.53	A	2.50 + 2.50	5.00 (2.20-6.40)	1380 (390-2750)	3.62	A
	18 + 25	1.80 + 2.50	4.30 (2.00-4.70)	1120 (380-1360)	3.84	A	2.50 + 3.40	5.90 (2.20-7.20)	1610 (390-3000)	3.66	A
	18 + 35	1.80 + 3.50	5.30 (2.00-5.80)	1600 (380-1950)	3.31	A	2.50 + 4.30	6.80 (2.20-7.20)	1850 (390-3120)	3.68	A
	18 + 50	1.80 + 5.00	6.80 (2.00-7.10)	2050 (380-2820)	3.32	A	2.36 + 6.14	8.50 (2.20-9.50)	2350 (390-3120)	3.62	A
	25 + 25	2.50 + 2.50	5.00 (2.00-5.50)	1410 (380-1720)	3.55	A	3.40 + 3.40	6.80 (2.20-9.50)	2000 (390-3120)	3.40	B
	25 + 35	2.50 + 3.50	6.00 (2.00-6.60)	1850 (380-2380)	3.24	A	3.40 + 4.30	7.70 (2.20-9.50)	2120 (390-3120)	3.63	A
	25 + 50	2.40 + 4.70	6.80 (2.00-7.50)	2060 (380-2980)	3.30	A	2.92 + 5.58	8.50 (2.20-9.50)	2350 (390-3120)	3.62	A
	35 + 35	3.50 + 3.50	6.80 (2.00-7.40)	2060 (380-2940)	3.30	A	4.25 + 4.25	8.50 (2.20-9.50)	2350 (390-3120)	3.62	A
	35 + 50	2.90 + 4.20	6.80 (2.00-7.50)	2060 (380-2890)	3.30	A	3.38 + 5.12	8.50 (2.20-9.50)	2350 (390-3120)	3.62	A
	50 + 50	3.55 + 3.55	6.80 (2.00-8.00)	2060 (380-3170)	3.30	A	4.25 + 4.25	8.50 (2.20-9.50)	2350 (390-3120)	3.62	A
3 UNITS	15 + 15 + 15	1.50 + 1.50 + 1.50	4.50 (2.20-5.00)	1400 (420-1680)	3.21	A	2.00 + 2.00 + 2.00	6.00 (2.40-6.50)	1650 (430-1800)	3.64	A
	15 + 15 + 18	1.50 + 1.50 + 1.80	4.80 (2.20-5.50)	1480 (240-1880)	3.24	A	2.00 + 2.00 + 2.50	6.50 (2.40-7.00)	1750 (430-2100)	3.71	A
	15 + 15 + 25	1.50 + 1.50 + 2.50	5.50 (2.20-6.00)	1680 (420-2280)	3.27	A	2.00 + 2.00 + 3.40	7.40 (2.20-9.30)	2010 (430-2200)	3.68	A
	15 + 15 + 35	1.50 + 1.50 + 3.50	6.50 (2.20-7.00)	2010 (420-2480)	3.23	A	2.00 + 2.00 + 4.30	8.30 (2.40-9.50)	2260 (430-2500)	3.67	A
	15 + 15 + 50	1.28 + 1.28 + 4.25	6.80 (2.20-7.50)	2100 (420-2890)	3.24	A	1.62 + 1.62 + 5.26	8.50 (2.40-9.50)	2300 (430-2600)	3.70	A
	15 + 18 + 18	1.50 + 1.80 + 1.80	5.10 (2.20-5.60)	1550 (420-2280)	3.29	A	2.00 + 2.50 + 2.50	7.00 (2.20-9.30)	1900 (430-2400)	3.68	A
	15 + 18 + 25	1.50 + 1.80 + 2.50	5.80 (2.20-6.30)	1800 (420-2480)	3.22	A	2.00 + 2.50 + 3.40	7.90 (2.40-9.50)	2150 (430-2600)	3.67	A
	15 + 18 + 35	1.50 + 1.80 + 3.50	6.80 (2.20-7.50)	2100 (420-2480)	3.24	A	1.93 + 2.41 + 4.15	8.50 (2.40-9.50)	2290 (430-2600)	3.71	A
	15 + 18 + 50	1.23 + 1.47 + 4.10	6.80 (2.20-7.50)	2100 (420-2890)	3.24	A	1.55 + 1.93 + 5.02	8.50 (2.40-9.50)	2290 (430-2600)	3.71	A
	15 + 25 + 25	1.50 + 2.50 + 2.50	6.50 (1.50-7.00)	2020 (420-2480)	3.22	A	1.93 + 3.28 + 3.28	8.50 (2.40-9.50)	2290 (430-2600)	3.71	A
	15 + 25 + 35	1.36 + 2.27 + 3.17	6.80 (2.20-7.80)	2100 (420-2890)	3.24	A	1.75 + 2.98 + 3.77	8.50 (2.40-9.50)	2290 (430-2600)	3.71	A
	15 + 25 + 50	1.13 + 1.89 + 3.78	6.80 (2.20-8.00)	2100 (420-2960)	3.24	A	1.43 + 2.43 + 4.64	8.50 (2.40-9.50)	2310 (430-2600)	3.68	A
	15 + 35 + 35	1.20 + 2.80 + 2.80	6.80 (2.20-8.00)	2100 (420-2890)	3.24	A	1.60 + 3.45 + 3.45	8.50 (2.40-9.50)	2310 (430-2600)	3.68	A
	15 + 35 + 50	1.02 + 2.38 + 3.40	6.80 (2.20-8.00)	2100 (420-2960)	3.24	A	1.33 + 2.86 + 4.32	8.50 (2.40-9.50)	2310 (430-2600)	3.68	A
	18 + 18 + 18	1.80 + 1.80 + 1.80	5.40 (2.20-5.90)	1450 (420-2190)	3.72	A	2.50 + 2.50 + 2.50	7.50 (2.40-9.50)	2050 (430-2600)	3.66	A
	18 + 18 + 25	1.80 + 1.80 + 2.50	6.10 (2.20-6.70)	1720 (420-2480)	3.55	A	2.50 + 2.50 + 3.40	8.40 (2.40-9.50)	2290 (430-2600)	3.67	A
	18 + 18 + 35	1.72 + 1.72 + 3.35	6.80 (2.20-7.80)	2080 (420-2890)	3.27	A	2.28 + 2.28 + 3.93	8.50 (2.40-9.50)	2290 (430-2600)	3.71	A
	18 + 18 + 50	1.42 + 1.42 + 3.95	6.80 (2.20-8.00)	2080 (420-2960)	3.27	A	1.85 + 1.85 + 4.80	8.50 (2.40-9.50)	2280 (430-2600)	3.73	A
	18 + 25 + 25	1.80 + 2.50 + 2.50	6.80 (2.20-7.50)	2080 (420-2780)	3.27	A	2.28 + 3.11 + 3.11	8.50 (2.40-9.50)	2290 (430-2600)	3.71	A
	18 + 25 + 35	1.57 + 2.18 + 3.05	6.80 (2.20-8.00)	2080 (420-2960)	3.27	A	2.08 + 2.83 + 3.58	8.50 (2.40-9.50)	2290 (430-2600)	3.71	A
	18 + 25 + 50	1.32 + 1.83 + 3.66	6.80 (2.20-8.00)	2080 (440-2770)	3.27	A	1.71 + 2.33 + 4.46	8.50 (2.40-9.50)	2280 (430-2600)	3.73	A
	18 + 35 + 35	1.39 + 2.70 + 2.70	6.80 (2.20-8.00)	2080 (420-2960)	3.27	A	1.91 + 3.29 + 3.29	8.50 (2.40-9.50)	2290 (430-2600)	3.71	A
	18 + 35 + 50	1.19 + 2.31 + 3.30	6.80 (2.20-8.00)	2080 (420-2960)	3.27	A	1.60 + 2.75 + 4.15	8.50 (2.40-9.50)	2280 (430-2600)	3.73	A
	25 + 25 + 25	2.27 + 2.27 + 2.27	6.80 (2.20-7.80)	2080 (420-2890)	3.27	A	2.83 + 2.83 + 2.83	8.50 (2.40-9.50)	2290 (430-2600)	3.71	A
	25 + 25 + 35	2.00 + 2.00 + 2.80	6.80 (2.20-8.00)	2080 (420-2960)	3.27	A	2.60 + 2.60 + 3.29	8.50 (2.40-9.50)	2290 (430-2600)	3.71	A
	25 + 25 + 50	1.70 + 1.70 + 3.40	6.80 (2.20-8.00)	2080 (420-2960)	3.27	A	2.17 + 2.17 + 4.15	8.50 (2.40-9.50)	2280 (430-2600)	3.73	A
	25 + 35 + 35	1.79 + 2.51 + 2.51	6.80 (2.20-8.00)	2080 (420-2960)	3.27	A	2.41 + 3.05 + 3.05	8.50 (2.40-9.50)	2290 (430-2600)	3.71	A
25 + 35 + 50	1.55 + 2.16 + 3.09	6.80 (2.20-8.00)	2080 (420-2960)	3.27	A	2.04 + 2.57 + 3.89	8.50 (2.40-9.50)	2280 (430-2600)	3.73	A	
35 + 35 + 35	2.27 + 2.27 + 2.27	6.80 (2.20-8.00)	2080 (420-2960)	3.27	A	2.83 + 2.83 + 2.83	8.50 (2.40-9.50)	2280 (430-2600)	3.73	A	

[1] This combination needs to add a cooling adapter to go from 0.95 to 1.27 when installing the size 50 indoor unit.



Hotel Nanín, Sanxexo  
 Multizone Air Conditioning  
 More info: [www.hitachiaircon.es](http://www.hitachiaircon.es)



◀ **RAM-68NP3B  
 FRIGORIFIC LENGTHS**

(L1+L2+L3)= max 60 m.  
 The minimum pipe length for each indoor unit is 3 m.  
 The maximum piping length for an indoor unit is 25 m.  
 The height difference between the indoor units must not exceed 5 m.  
 Maximum height 20 m.

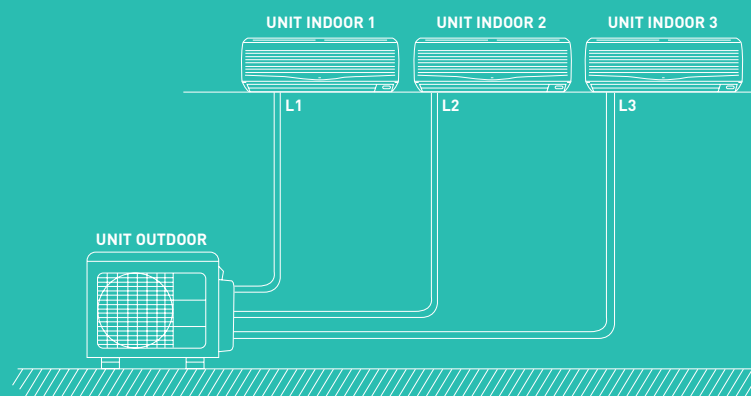



**MULTIZONE  
COMBINATIONS**

# RAM-70NP4B

POSSIBLE COMBINATIONS OF INDOOR UNITS	COOLING MODE					HEATING MODE					
	Unit power (kW)	Total power (kW)	Total Abs. power (W)	EER	Energy class	Unit power (kW)	Total power (kW)	Total Abs. power (W)	COP	Energy class	
2 UNITS	15 + 15	1.50 + 1.50	3.00 (1.50-2.80)	870 (380-980)	3.45	A	2.00 + 2.00	4.00 (2.20-4.70)	1080 (200-1100)	3.70	A
	15 + 18	1.50 + 1.80	3.30 (1.50-3.50)	950 (380-1000)	3.47	A	2.00 + 2.50	4.50 (2.20-5.20)	1200 (200-1300)	3.75	A
	15 + 25	1.50 + 2.50	4.00 (1.50-4.00)	1150 (380-1300)	3.48	A	2.00 + 3.40	5.40 (2.20-6.40)	1450 (200-1780)	3.72	A
	15 + 35	1.50 + 3.50	5.00 (1.50-5.20)	1450 (380-1450)	3.45	A	2.00 + 4.30	6.30 (2.20-7.20)	1660 (200-2010)	3.80	A
	15 + 50	1.50 + 5.00	6.50 (1.50-5.90)	1950 (380-2380)	3.33	A	2.00 + 6.50	8.50 (2.20-7.20)	2200 (390-3120)	3.86	A
	18 + 18	1.80 + 1.80	3.60 (2.00-4.00)	1020 (380-1020)	3.53	A	2.50 + 2.50	5.00 (2.20-6.40)	1380 (390-2750)	3.62	A
	18 + 25	1.80 + 2.50	4.30 (2.00-4.70)	1120 (380-1360)	3.84	A	2.50 + 3.40	5.90 (2.20-7.20)	1610 (390-3000)	3.66	A
	18 + 35	1.80 + 3.50	5.30 (2.00-5.80)	1600 (380-1950)	3.31	A	2.50 + 4.30	6.80 (2.20-7.20)	1850 (390-3120)	3.68	A
	18 + 50	1.80 + 5.00	6.80 (2.00-7.10)	2050 (380-2820)	3.32	A	2.36 + 6.14	8.50 (2.20-9.50)	2350 (390-3120)	3.62	A
	25 + 25	2.50 + 2.50	5.00 (2.00-5.50)	1410 (380-1720)	3.55	A	3.40 + 3.40	6.80 (2.20-9.50)	1850 (390-3120)	3.68	A
	25 + 35	2.50 + 3.50	6.00 (2.00-6.60)	1850 (380-2380)	3.24	A	3.60 + 4.30	7.70 (2.20-9.50)	2120 (390-3120)	3.63	A
	25 + 50	2.33 + 4.67	7.00 (2.00-7.50)	2060 (380-2980)	3.40	A	2.92 + 5.58	8.50 (2.20-9.50)	2350 (390-3120)	3.62	A
	35 + 35	3.50 + 3.50	7.00 (2.00-7.40)	2060 (380-2940)	3.40	A	4.25 + 4.25	8.50 (2.20-9.50)	2350 (390-3120)	3.62	A
	35 + 50	2.88 + 4.12	7.00 (2.00-7.50)	2060 (380-2890)	3.40	A	3.38 + 5.12	8.50 (2.20-9.50)	2350 (390-3120)	3.62	A
	50 + 50	3.50 + 3.50	7.00 (2.00-8.00)	2060 (380-3170)	3.40	A	4.25 + 4.25	8.50 (2.20-9.50)	2350 (390-3120)	3.62	A
3 UNITS	15 + 15 + 15	1.50 + 1.50 + 1.50	4.50 (2.20-5.00)	1400 (420-1680)	3.21	A	2.00 + 2.00 + 2.00	6.00 (2.40-6.50)	1650 (430-1800)	3.64	A
	15 + 15 + 18	1.50 + 1.50 + 1.80	4.80 (2.20-5.50)	1480 (240-1880)	3.24	A	2.00 + 2.00 + 2.50	6.50 (2.40-7.00)	1750 (430-2100)	3.71	A
	15 + 15 + 25	1.50 + 1.50 + 2.50	5.50 (2.20-6.00)	1680 (420-2280)	3.27	A	2.00 + 2.00 + 3.40	7.40 (2.20-9.30)	2010 (430-2200)	3.68	A
	15 + 15 + 35	1.50 + 1.50 + 3.50	6.50 (2.20-7.00)	2010 (420-2480)	3.23	A	2.00 + 2.00 + 4.30	8.30 (2.40-9.50)	2260 (430-2500)	3.67	A
	15 + 15 + 50	1.31 + 1.31 + 4.38	7.00 (2.20-7.50)	2100 (420-2890)	3.33	A	1.62 + 1.62 + 5.26	8.50 (2.40-9.50)	2300 (430-2600)	3.70	A
	15 + 18 + 18	1.50 + 1.80 + 1.80	5.10 (2.20-5.60)	1550 (420-2280)	3.29	A	2.00 + 2.50 + 2.50	7.00 (2.20-9.30)	1900 (430-2400)	3.68	A
	15 + 18 + 25	1.50 + 1.80 + 2.50	5.80 (2.20-6.30)	1800 (420-2480)	3.22	A	2.00 + 2.50 + 3.40	7.90 (2.40-9.50)	2150 (430-2600)	3.67	A
	15 + 18 + 35	1.50 + 1.80 + 3.50	6.80 (2.20-7.50)	2100 (420-2480)	3.24	A	1.93 + 2.41 + 4.15	8.50 (2.40-9.50)	2290 (430-2600)	3.71	A
	15 + 18 + 50	1.27 + 1.52 + 4.22	7.00 (2.20-7.50)	2100 (420-2890)	3.33	A	1.55 + 1.93 + 5.02	8.50 (2.40-9.50)	2290 (430-2600)	3.71	A
	15 + 25 + 25	1.50 + 2.50 + 2.50	6.50 (2.20-7.00)	2020 (420-2480)	3.22	A	1.93 + 3.28 + 3.28	8.50 (2.40-9.50)	2290 (430-2600)	3.71	A
	15 + 25 + 35	1.40 + 2.33 + 3.27	7.00 (2.20-7.80)	2100 (420-2890)	3.33	A	1.75 + 2.98 + 3.77	8.50 (2.40-9.50)	2290 (430-2600)	3.71	A
	15 + 25 + 50	1.17 + 1.94 + 3.89	7.00 (2.20-8.00)	2100 (420-2960)	3.33	A	1.43 + 2.43 + 4.64	8.50 (2.40-9.50)	2310 (430-2600)	3.68	A
	15 + 35 + 35	1.24 + 2.88 + 2.88	7.00 (2.20-8.00)	2100 (420-2890)	3.33	A	1.60 + 3.45 + 3.45	8.50 (2.40-9.50)	2310 (430-2600)	3.68	A
	15 + 35 + 50	1.05 + 2.45 + 3.50	7.00 (2.20-8.00)	2100 (420-2960)	3.33	A	1.33 + 2.86 + 4.32	8.50 (2.40-9.50)	2310 (430-2600)	3.68	A
	18 + 18 + 18	1.80 + 1.80 + 1.80	5.40 (2.20-5.90)	1450 (420-2190)	3.72	A	2.50 + 2.50 + 2.50	7.50 (2.40-9.50)	2050 (430-2600)	3.66	A
	18 + 18 + 25	1.80 + 1.80 + 2.50	6.10 (2.20-6.70)	1720 (420-2480)	3.55	A	2.50 + 2.50 + 3.40	8.40 (2.40-9.50)	2290 (430-2600)	3.67	A
	18 + 18 + 35	1.77 + 1.77 + 3.45	7.00 (2.20-7.80)	2080 (420-2890)	3.37	A	2.28 + 2.28 + 3.93	8.50 (2.40-9.50)	2290 (430-2600)	3.71	A
	18 + 18 + 50	1.47 + 1.47 + 4.07	7.00 (2.20-8.00)	2080 (420-2890)	3.37	A	1.85 + 1.85 + 4.80	8.50 (2.40-9.50)	2280 (430-2600)	3.73	A
	18 + 25 + 25	1.80 + 2.50 + 2.50	6.80 (2.20-7.50)	2080 (420-2780)	3.27	A	2.28 + 3.11 + 3.11	8.50 (2.40-9.50)	2290 (430-2600)	3.71	A
	18 + 25 + 35	1.62 + 2.24 + 3.14	7.00 (2.20-8.00)	2080 (420-2890)	3.37	A	2.08 + 2.83 + 3.58	8.50 (2.40-9.50)	2290 (430-2600)	3.71	A
	18 + 25 + 50	1.35 + 1.88 + 3.76	7.00 (2.20-8.00)	2080 (420-2770)	3.37	A	1.71 + 2.33 + 4.46	8.50 (2.40-9.50)	2280 (430-2600)	3.73	A
	18 + 35 + 35	1.43 + 2.78 + 2.78	7.00 (2.20-8.00)	2080 (420-2960)	3.37	A	1.91 + 3.29 + 3.29	8.50 (2.40-9.50)	2290 (430-2600)	3.71	A
	18 + 35 + 50	1.22 + 2.38 + 3.40	7.00 (2.20-8.00)	2080 (420-2960)	3.37	A	1.60 + 2.75 + 4.15	8.50 (2.40-9.50)	2280 (430-2600)	3.73	A
	25 + 25 + 25	2.33 + 2.33 + 2.33	7.00 (2.20-7.80)	2080 (420-2890)	3.37	A	2.83 + 2.83 + 2.83	8.50 (2.40-9.50)	2290 (430-2600)	3.71	A
	25 + 25 + 35	2.06 + 2.06 + 2.88	7.00 (2.20-8.00)	2080 (420-2960)	3.37	A	2.60 + 2.60 + 3.29	8.50 (2.40-9.50)	2290 (430-2600)	3.71	A
	25 + 25 + 50	1.75 + 1.75 + 3.50	7.00 (2.20-8.00)	2080 (420-2960)	3.37	A	2.17 + 2.17 + 4.15	8.50 (2.40-9.50)	2280 (430-2600)	3.73	A
	25 + 35 + 35	1.84 + 2.58 + 2.58	7.00 (2.20-8.00)	2080 (420-2960)	3.37	A	2.41 + 3.05 + 3.05	8.50 (2.40-9.50)	2290 (430-2600)	3.71	A
25 + 35 + 50	1.59 + 2.23 + 3.18	7.00 (2.20-8.00)	2080 (420-2960)	3.37	A	2.04 + 2.57 + 3.89	8.50 (2.40-9.50)	2280 (430-2600)	3.73	A	
35 + 35 + 35	2.33 + 2.33 + 2.33	7.00 (2.20-8.00)	2080 (420-2960)	3.37	A	2.83 + 2.83 + 2.83	8.50 (2.40-9.50)	2280 (430-2600)	3.73	A	

POSSIBLE COMBINATIONS OF INDOOR UNITS	COOLING MODE					HEATING MODE				
	Unit power (kW)	Total power (kW)	Total Abs. power (W)	EER	Energy class	Unit power (kW)	Total power (kW)	Total Abs. power (W)	COP	Energy class
15 + 15 + 15 + 15	1.50 + 1.50 + 1.50 + 1.50	6.00 (2.20~6.50)	1600 (200~1660)	3.75	A	2.00 + 2.00 + 2.00 + 2.00	8.00 (2.60~9.00)	2150 (460~2420)	3.72	A
15 + 15 + 15 + 18	1.50 + 1.50 + 1.50 + 1.80	6.30 (2.20~6.70)	1650 (420~2010)	3.82	A	2.00 + 2.00 + 2.00 + 2.50	8.50 (2.60~9.50)	2180 (460~2520)	3.90	A
15 + 15 + 15 + 25	1.50 + 1.50 + 1.50 + 2.50	7.00 (2.20~7.50)	1890 (420~2010)	3.70	A	1.81 + 1.81 + 1.81 + 3.07	8.50 (2.60~9.50)	2200 (480~2580)	3.86	A
15 + 15 + 15 + 35	1.31 + 1.31 + 1.31 + 3.06	7.00 (2.40~7.90)	2140 (450~2650)	3.27	A	1.65 + 1.65 + 1.65 + 3.55	8.50 (2.60~9.50)	2200 (480~2580)	3.86	A
15 + 15 + 15 + 50	1.11 + 1.11 + 1.11 + 3.68	7.00 (2.40~8.50)	2140 (450~2650)	3.27	A	1.36 + 1.36 + 1.36 + 4.42	8.50 (2.60~9.50)	2200 (480~2580)	3.86	A
15 + 15 + 18 + 18	1.50 + 1.50 + 1.80 + 1.80	6.60 (2.20~7.00)	1850 (420~2010)	3.57	A	1.89 + 1.89 + 2.36 + 2.36	8.50 (2.60~9.50)	2200 (480~2580)	3.86	A
15 + 15 + 18 + 25	1.44 + 1.44 + 1.73 + 2.40	7.00 (2.40~7.50)	2010 (420~2310)	3.48	A	1.72 + 1.72 + 2.15 + 2.92	8.50 (2.60~9.50)	2200 (480~2580)	3.86	A
15 + 15 + 18 + 35	1.27 + 1.27 + 1.52 + 2.95	7.00 (2.40~7.70)	2140 (450~2650)	3.27	A	1.57 + 1.57 + 1.97 + 3.38	8.50 (2.60~9.50)	2200 (480~2580)	3.86	A
15 + 15 + 18 + 50	1.07 + 1.07 + 1.29 + 3.57	7.00 (2.40~7.70)	2140 (450~2650)	3.27	A	1.31 + 1.31 + 1.63 + 4.25	8.50 (2.60~9.50)	2200 (480~2580)	3.86	A
15 + 15 + 25 + 25	1.31 + 1.31 + 2.19 + 2.19	7.00 (2.40~7.90)	2140 (450~2650)	3.27	A	1.57 + 1.57 + 2.68 + 2.68	8.50 (2.60~9.50)	2200 (480~2580)	3.86	A
15 + 15 + 25 + 35	1.17 + 1.17 + 1.94 + 2.72	7.00 (2.40~7.90)	2140 (450~2650)	3.27	A	1.45 + 1.45 + 2.47 + 3.12	8.50 (2.60~9.50)	2200 (480~2580)	3.86	A
15 + 15 + 25 + 50	1.00 + 1.00 + 1.67 + 3.33	7.00 (2.40~8.50)	2140 (450~2650)	3.27	A	1.22 + 1.22 + 2.08 + 3.97	8.50 (2.60~9.50)	2180 (460~2520)	3.90	A
15 + 15 + 35 + 35	1.05 + 1.05 + 2.45 + 2.45	7.00 (2.40~8.50)	2140 (450~2650)	3.27	A	1.35 + 1.35 + 2.90 + 2.90	8.50 (2.60~9.50)	2200 (480~2580)	3.86	A
15 + 15 + 35 + 50	0.91 + 0.91 + 2.13 + 3.04	7.00 (2.40~8.80)	2140 (450~3020)	3.27	A	1.15 + 1.15 + 2.47 + 3.73	8.50 (2.60~9.50)	2180 (460~2520)	3.90	A
15 + 18 + 18 + 18	1.50 + 1.80 + 1.80 + 1.80	6.90 (2.40~7.50)	2010 (420~2310)	3.43	A	1.79 + 2.24 + 2.24 + 2.24	8.50 (2.60~9.50)	2200 (480~2580)	3.86	A
15 + 18 + 18 + 25	1.38 + 1.66 + 1.66 + 2.30	7.00 (2.40~7.90)	2140 (450~2650)	3.27	A	1.63 + 2.04 + 2.04 + 2.78	8.50 (2.60~9.50)	2200 (480~2580)	3.86	A
15 + 18 + 18 + 35	1.22 + 1.47 + 1.47 + 2.85	7.00 (2.40~7.90)	2140 (450~2650)	3.27	A	1.50 + 1.88 + 1.88 + 3.23	8.50 (2.60~9.50)	2200 (480~2580)	3.86	A
15 + 18 + 18 + 50	1.04 + 1.25 + 1.25 + 3.47	7.00 (2.40~8.80)	2140 (450~2650)	3.27	A	1.26 + 1.57 + 1.57 + 4.09	8.50 (2.60~9.50)	2180 (460~2520)	3.90	A
15 + 18 + 25 + 25	1.27 + 1.52 + 2.11 + 2.11	7.00 (2.40~7.90)	2140 (450~2650)	3.27	A	1.50 + 1.88 + 2.56 + 2.56	8.50 (2.60~9.50)	2200 (480~2580)	3.86	A
15 + 18 + 25 + 35	1.13 + 1.35 + 1.88 + 2.63	7.00 (2.40~7.90)	2140 (450~2650)	3.27	A	1.39 + 1.74 + 2.37 + 3.00	8.50 (2.60~9.50)	2200 (480~2580)	3.86	A
15 + 18 + 25 + 50	0.97 + 1.17 + 1.62 + 3.24	7.00 (2.40~8.80)	2140 (450~3020)	3.27	A	1.18 + 1.48 + 2.01 + 3.84	8.50 (2.60~9.50)	2180 (460~2520)	3.90	A
15 + 18 + 35 + 35	1.02 + 1.22 + 2.38 + 2.38	7.00 (2.40~7.90)	2140 (450~3020)	3.27	A	1.30 + 1.62 + 2.79 + 2.79	8.50 (2.60~9.50)	2200 (480~2580)	3.86	A
15 + 25 + 25 + 25	1.17 + 1.94 + 1.94 + 1.94	7.00 (2.40~7.90)	2140 (450~2650)	3.27	A	1.39 + 2.37 + 2.37 + 2.37	8.50 (2.60~9.50)	2200 (480~2580)	3.86	A
15 + 25 + 25 + 35	1.05 + 1.75 + 1.75 + 2.45	7.00 (2.40~8.80)	2140 (450~2650)	3.27	A	1.30 + 2.21 + 2.21 + 2.79	8.50 (2.60~9.50)	2200 (480~2580)	3.86	A
15 + 25 + 35 + 35	0.95 + 1.59 + 2.23 + 2.23	7.00 (2.40~8.80)	2140 (450~3020)	3.27	A	1.21 + 2.06 + 2.61 + 2.61	8.50 (2.60~9.50)	2180 (460~2520)	3.90	A
18 + 18 + 18 + 18	1.75 + 1.75 + 1.75 + 1.75	7.00 (2.40~7.90)	2110 (450~2870)	3.32	A	2.13 + 2.13 + 2.13 + 2.13	8.50 (2.60~9.50)	2120 (480~2580)	4.01	A
18 + 18 + 18 + 25	1.59 + 1.59 + 1.59 + 2.22	7.00 (2.40~7.90)	2110 (450~3020)	3.32	A	1.95 + 1.95 + 1.95 + 2.65	8.50 (2.60~9.50)	2120 (480~2580)	4.01	A
18 + 18 + 18 + 35	1.42 + 1.42 + 1.42 + 2.75	7.00 (2.40~8.50)	2110 (450~3090)	3.32	A	1.80 + 1.80 + 1.80 + 3.10	8.50 (2.60~9.50)	2120 (460~2520)	4.01	A
18 + 18 + 18 + 50	1.21 + 1.21 + 1.21 + 3.37	7.00 (2.40~8.80)	2110 (450~3200)	3.32	A	1.52 + 1.52 + 1.52 + 3.95	8.50 (2.60~9.50)	2110 (460~2520)	4.03	A
18 + 18 + 25 + 25	1.47 + 1.47 + 2.03 + 2.03	7.00 (2.40~8.50)	2110 (450~3090)	3.32	A	1.80 + 1.80 + 2.45 + 2.45	8.50 (2.60~9.50)	2120 (460~2520)	4.01	A
18 + 18 + 25 + 35	1.31 + 1.31 + 1.82 + 2.55	7.00 (2.40~8.50)	2110 (450~3090)	3.32	A	1.67 + 1.67 + 2.28 + 2.88	8.50 (2.60~9.50)	2120 (460~2520)	4.01	A
18 + 18 + 35 + 35	1.19 + 1.19 + 2.31 + 2.31	7.00 (2.40~8.80)	2110 (450~3200)	3.32	A	1.56 + 1.56 + 2.69 + 2.69	8.50 (2.60~9.50)	2110 (460~2520)	4.03	A
18 + 25 + 25 + 25	1.35 + 1.88 + 1.88 + 1.88	7.00 (2.40~8.50)	2110 (450~3090)	3.32	A	1.67 + 2.28 + 2.28 + 2.28	8.50 (2.60~9.50)	2120 (460~2520)	4.01	A
18 + 25 + 25 + 35	1.22 + 1.70 + 1.70 + 2.38	7.00 (2.40~8.80)	2110 (450~3200)	3.32	A	1.56 + 2.13 + 2.13 + 2.69	8.50 (2.60~9.50)	2110 (460~2520)	4.03	A
25 + 25 + 25 + 25	1.75 + 1.75 + 1.75 + 1.75	7.00 (2.40~8.80)	2110 (450~3200)	3.32	A	2.13 + 2.13 + 2.13 + 2.13	8.50 (2.60~9.50)	2110 (460~2520)	4.03	A
25 + 25 + 25 + 35	1.59 + 1.59 + 1.59 + 2.23	7.00 (2.40~8.80)	2110 (450~3200)	3.32	A	1.99 + 1.99 + 1.99 + 2.52	8.50 (2.60~9.50)	2110 (460~2520)	4.03	A

**RAM-70NP4B ▲**  
**FRIGORIFIC LENGTHS**

(L1+L2+L3+L4)= max 60 m.  
(L1+L2+L3+L4)= 25 m  
Preload for 30 m.  
Provide 20 g/m of refrigerant beyond 30 m.  
Maximum height between the highest indoor unit and the lowest indoor unit: 5 m.  
Always connect the most powerful indoor unit to the lowest connection.  
Maximum height 20 m.

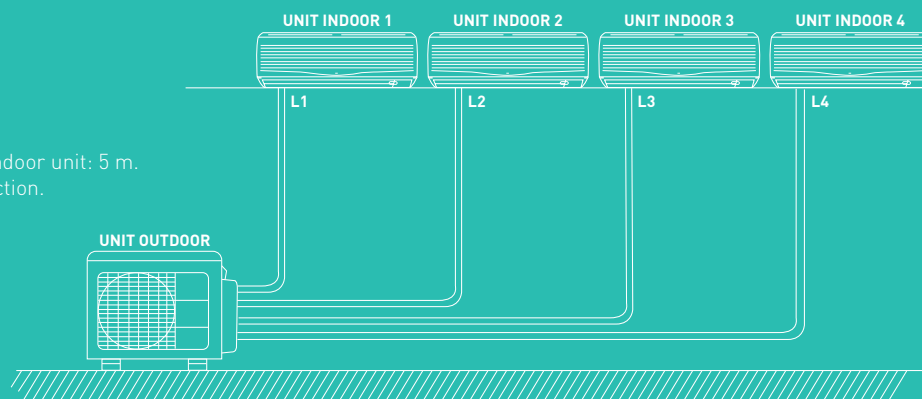

**MULTIZONE  
COMBINATIONS**

# RAM-90NP5B

POSSIBLE COMBINATIONS OF INDOOR UNITS	COOLING MODE					HEATING MODE					
	Unit power (kW)	Total power (kW)	Total Abs. power (W)	EER	Energy class	Unit power (kW)	Total power (kW)	Total Abs. power (W)	COP	Energy class	
2 UNITS	15 + 15	1.50 + 1.50	3.00 (2.40~3.50)	850 (450~1020)	3.53	A	2.00 + 2.00	4.00 (2.70~4.50)	950 (480~1140)	4.21	A
	15 + 18	1.50 + 1.80	3.30 (2.40~3.80)	950 (450~1140)	3.47	A	2.00 + 2.50	4.50 (2.70~5.00)	1180 (480~1416)	3.81	A
	15 + 25	1.50 + 2.50	4.00 (2.40~4.50)	1250 (450~1500)	3.20	A	2.00 + 3.40	5.40 (2.70~5.90)	1320 (480~1584)	4.09	A
	15 + 35	1.50 + 3.50	5.00 (2.40~5.50)	1550 (450~1860)	3.23	A	2.00 + 4.30	6.30 (2.70~6.80)	1550 (480~1860)	4.06	A
	15 + 50	1.50 + 5.00	6.50 (2.40~7.00)	2100 (450~2520)	3.10	B	2.00 + 6.50	8.50 (2.70~9.00)	2300 (480~2760)	3.70	A
	18 + 18	1.80 + 1.80	3.60 (2.40~4.00)	820 (450~860)	4.39	A	2.50 + 2.50	5.00 (2.70~6.90)	1240 (480~1710)	4.03	A
	18 + 25	1.80 + 2.50	4.30 (2.40~4.70)	1000 (450~1190)	4.30	A	2.50 + 3.40	5.90 (2.70~7.70)	1530 (480~1990)	3.86	A
	18 + 35	1.80 + 3.50	5.30 (2.40~5.80)	1590 (450~1900)	3.33	A	2.50 + 4.30	6.80 (2.70~8.50)	1870 (480~2320)	3.64	A
	18 + 50	1.80 + 5.00	6.80 (2.40~7.50)	2370 (450~2970)	2.87	C	2.39 + 6.21	8.60 (2.70~10.00)	2470 (480~2880)	3.48	B
	25 + 25	2.50 + 2.50	5.00 (2.40~5.50)	1370 (450~1640)	3.65	A	3.40 + 3.40	6.80 (2.70~8.50)	1810 (480~2250)	3.76	A
	25 + 35	2.50 + 3.50	6.00 (2.40~6.60)	2000 (450~2400)	3.00	B	3.40 + 4.30	7.70 (2.70~9.20)	2160 (480~2590)	3.56	B
	25 + 50	2.50 + 5.00	7.50 (2.40~8.30)	2580 (450~3470)	2.91	C	3.16 + 6.04	9.20 (2.70~10.50)	2720 (480~3110)	3.38	C
	35 + 35	3.50 + 3.50	7.00 (2.40~7.70)	2490 (450~2990)	2.81	C	4.30 + 4.30	8.60 (2.70~10.00)	2460 (480~2860)	3.50	B
	35 + 50	3.50 + 5.00	8.50 (2.40~8.80)	2900 (450~3270)	2.93	C	3.86 + 5.84	9.70 (2.70~11.00)	2940 (480~3320)	3.30	C
	50 + 50	4.25 + 4.25	8.50 (2.40~9.20)	2930 (450~3460)	2.90	C	5.10 + 5.10	10.20 (2.70~11.40)	2860 (480~3200)	3.57	B
	3 UNITS	15 + 15 + 15	1.50 + 1.50 + 1.50	4.50 (2.70~5.00)	1250 (510~1500)	3.60	A	2.00 + 2.00 + 2.00	6.00 (2.90~6.50)	1540 (520~1848)	3.90
15 + 15 + 18		1.50 + 1.50 + 1.80	4.80 (2.70~5.30)	1350 (510~1620)	3.56	A	2.00 + 2.00 + 2.50	6.50 (2.90~7.00)	1800 (520~2160)	3.61	A
15 + 15 + 25		1.50 + 1.50 + 2.50	5.50 (2.70~6.00)	1490 (510~1788)	3.69	A	2.00 + 2.00 + 3.40	7.40 (2.90~7.90)	2010 (520~2412)	3.68	A
15 + 15 + 35		1.50 + 1.50 + 3.50	6.50 (2.70~7.00)	2100 (510~2520)	3.10	B	2.00 + 2.00 + 4.30	8.30 (2.90~8.80)	2420 (520~2904)	3.43	B
15 + 15 + 50		1.50 + 1.50 + 5.00	8.00 (2.70~8.50)	2230 (510~2676)	3.59	A	2.00 + 2.00 + 6.50	10.50 (2.90~11.00)	2300 (520~1848)	4.57	A
15 + 18 + 18		1.50 + 1.80 + 1.80	5.10 (2.70~5.60)	1350 (510~1500)	3.78	A	2.00 + 2.50 + 2.50	7.00 (2.90~7.50)	1900 (520~2280)	3.68	A
15 + 18 + 25		1.50 + 1.80 + 2.50	5.80 (2.70~6.30)	1350 (510~1500)	3.89	A	2.00 + 2.50 + 3.40	7.90 (2.90~8.40)	2180 (520~2616)	3.62	A
15 + 18 + 35		1.50 + 1.80 + 3.50	6.80 (2.70~7.30)	2370 (510~2844)	2.87	C	2.00 + 2.50 + 4.30	8.80 (2.90~9.30)	2940 (520~1848)	3.83	A
15 + 18 + 50		1.50 + 1.80 + 5.00	8.30 (2.70~8.80)	1350 (510~1500)	3.72	A	2.00 + 2.50 + 6.50	11.00 (2.90~11.50)	2800 (520~3360)	3.93	A
15 + 25 + 25		1.50 + 2.50 + 2.50	6.50 (2.70~7.00)	2100 (510~2520)	3.10	B	2.00 + 3.40 + 3.40	8.80 (2.90~9.30)	2940 (520~1848)	3.83	A
15 + 25 + 35		1.50 + 2.50 + 3.50	7.50 (2.70~8.00)	2580 (510~3096)	2.91	C	2.00 + 3.40 + 4.30	9.70 (2.90~10.20)	2940 (520~3528)	3.30	C
15 + 25 + 50		1.50 + 2.50 + 5.00	9.00 (2.70~9.50)	1350 (510~1500)	3.36	A	1.85 + 3.14 + 6.01	11.00 (2.90~11.50)	2800 (520~3360)	3.93	A
15 + 35 + 35		1.50 + 3.50 + 3.50	8.50 (2.70~9.00)	2800 (510~3360)	3.04	B	2.00 + 4.30 + 4.30	10.60 (2.90~11.10)	2940 (520~1848)	3.61	A
15 + 35 + 50		1.35 + 3.15 + 4.50	9.00 (2.70~9.50)	2680 (510~3216)	3.36	A	1.72 + 3.70 + 5.59	11.00 (2.90~11.50)	2800 (520~3360)	3.93	A
15 + 50 + 50		1.17 + 3.91 + 3.91	9.00 (2.70~9.50)	2680 (510~3216)	3.36	A	1.47 + 4.77 + 4.77	11.00 (2.90~11.50)	2800 (520~3360)	3.93	A
18 + 18 + 18		1.80 + 1.80 + 1.80	5.40 (2.70~5.90)	1480 (510~1780)	3.65	A	2.50 + 2.50 + 2.50	7.50 (2.90~9.10)	2020 (520~2440)	3.71	A
18 + 18 + 25		1.80 + 1.80 + 2.50	6.10 (2.70~6.70)	1780 (510~2150)	3.43	A	2.38 + 2.38 + 3.24	8.00 (2.90~9.50)	2210 (520~2620)	3.62	A
18 + 18 + 35		1.80 + 1.80 + 3.50	7.10 (2.70~7.80)	1910 (510~2310)	3.72	A	2.37 + 2.37 + 4.06	8.80 (2.90~10.20)	2370 (520~2740)	3.71	A
18 + 18 + 50		1.78 + 1.78 + 4.94	8.50 (2.70~9.50)	2650 (510~3260)	3.21	A	2.20 + 2.20 + 5.70	10.10 (2.90~11.30)	2730 (520~3060)	3.70	A
18 + 25 + 25		1.80 + 2.50 + 2.50	6.8 (2.70~7.50)	1860 (510~2260)	3.66	A	2.30 + 3.15 + 3.15	8.60 (2.90~10.00)	2370 (520~2760)	3.63	A
18 + 25 + 35		1.80 + 2.50 + 3.50	7.80 (2.70~8.60)	2190 (510~2660)	3.56	A	2.30 + 3.13 + 3.96	9.40 (2.90~10.70)	2530 (520~2880)	3.72	A
18 + 25 + 50		1.66 + 2.26 + 4.58	8.50 (2.70~9.90)	2550 (510~3270)	3.33	A	2.10 + 2.85 + 5.45	10.40 (2.90~11.60)	2890 (520~3220)	3.60	B
18 + 35 + 35		1.74 + 3.38 + 3.38	8.50 (2.70~9.70)	2600 (510~3260)	3.27	A	2.34 + 4.03 + 4.03	10.40 (2.90~11.60)	2750 (520~3060)	3.78	A
18 + 35 + 50		1.47 + 2.88 + 4.16	8.50 (2.70~9.90)	2590 (510~3320)	3.28	A	1.95 + 3.36 + 5.09	10.40 (2.90~11.60)	2990 (520~3330)	3.48	B
18 + 50 + 50		1.31 + 3.60 + 3.60	8.50 (2.70~9.90)	2590 (510~3320)	3.28	A	1.68 + 4.36 + 4.36	10.40 (2.90~11.60)	2990 (520~3330)	3.48	B
25 + 25 + 25		2.50 + 2.50 + 2.50	7.50 (2.70~8.30)	2120 (510~2580)	3.54	A	3.00 + 3.00 + 3.00	9.00 (2.90~10.40)	2540 (520~2920)	3.54	B
25 + 25 + 35		2.50 + 2.50 + 3.50	8.50 (2.70~9.40)	2560 (510~3110)	3.32	A	3.06 + 3.06 + 3.87	10.00 (2.90~11.20)	2730 (520~3070)	3.66	A
25 + 25 + 50		2.13 + 2.13 + 4.25	8.50 (2.70~9.90)	2620 (510~3360)	3.24	A	2.66 + 2.66 + 5.08	10.40 (2.90~11.60)	2990 (520~3330)	3.48	B
25 + 35 + 35		2.23 + 3.13 + 3.13	8.50 (2.70~9.90)	2600 (510~3330)	3.27	A	2.95 + 3.73 + 3.73	10.40 (2.90~11.60)	2890 (520~3220)	3.60	B
25 + 35 + 50		1.93 + 2.69 + 3.87	8.50 (2.70~9.90)	2620 (510~3350)	3.24	A	2.49 + 3.14 + 4.77	10.40 (2.90~11.60)	2990 (520~3330)	3.48	B
25 + 50 + 50		1.70 + 3.40 + 3.40	8.50 (2.70~9.90)	2620 (510~3360)	3.24	A	2.18 + 4.16 + 4.16	10.50 (2.90~11.70)	2990 (520~3320)	3.51	B
35 + 35 + 35		2.83 + 2.83 + 2.83	8.50 (2.70~9.90)	2600 (510~3320)	3.27	A	3.47 + 3.47 + 3.47	10.40 (2.90~11.60)	2990 (520~3330)	3.48	B
35 + 35 + 50	2.50 + 2.50 + 3.49	8.50 (2.70~9.90)	2620 (510~3360)	3.24	A	2.99 + 3.01 + 4.47	10.50 (2.90~11.70)	2990 (520~3320)	3.51	B	
35 + 50 + 50	2.17 + 3.17 + 3.17	8.50 (2.70~9.90)	2620 (510~3360)	3.24	A	2.61 + 3.97 + 3.97	10.50 (2.90~11.70)	2990 (520~3320)	3.51	B	
50 + 50 + 50	2.83 + 2.83 + 2.83	8.50 (2.70~9.90)	2690 (510~3450)	3.16	B	3.67 + 3.67 + 3.67	11.00 (2.90~12.10)	2890 (520~3180)	3.81	A	



POSSIBLE COMBINATIONS OF INDOOR UNITS	COOLING MODE					HEATING MODE				
	Unit power (kW)	Total power (kW)	Total Abs. power (W)	EER	Energy class	Unit power (kW)	Total power (kW)	Total Abs. power (W)	COP	Energy class
15 + 15 + 15 + 15	1.50 + 1.50 + 1.50 + 1.50	6.00 (2.90-6.50)	1350 (550-1620)	4.44	A	2.00 + 2.00 + 2.00 + 2.00	8.00 (3.00-8.50)	2210 (540-2652)	3.62	A
15 + 15 + 15 + 18	1.50 + 1.50 + 1.50 + 1.80	6.30 (2.90-6.80)	1480 (550-1776)	4.26	A	2.00 + 2.00 + 2.00 + 2.50	8.50 (3.00-9.00)	2300 (540-2760)	3.70	A
15 + 15 + 15 + 25	1.50 + 1.50 + 1.50 + 2.50	7.00 (2.90-7.50)	1780 (550-2136)	3.93	A	2.00 + 2.00 + 2.00 + 3.40	9.40 (3.00-9.90)	2530 (540-3036)	3.72	A
15 + 15 + 15 + 35	1.50 + 1.50 + 1.50 + 3.50	8.00 (2.90-8.50)	1910 (550-2292)	4.19	A	2.00 + 2.00 + 2.00 + 4.30	10.30 (3.00-10.80)	2890 (540-3468)	3.56	B
15 + 15 + 15 + 50	1.34 + 1.34 + 1.34 + 4.47	8.50 (2.90-9.00)	2650 (550-3180)	3.21	A	1.76 + 1.76 + 1.76 + 5.72	11.00 (3.00-11.50)	2800 (540-3360)	3.93	A
15 + 15 + 18 + 18	1.50 + 1.50 + 1.80 + 1.80	6.60 (2.90-7.10)	1750 (550-2100)	3.77	A	2.00 + 2.00 + 2.50 + 2.50	9.00 (3.00-9.50)	2540 (540-3048)	3.54	B
15 + 15 + 18 + 25	1.50 + 1.50 + 1.80 + 2.50	7.30 (2.90-7.80)	1850 (550-2220)	3.95	A	2.00 + 2.00 + 2.50 + 3.40	9.90 (3.00-10.40)	2620 (540-3144)	3.63	A
15 + 15 + 18 + 35	1.50 + 1.50 + 1.80 + 3.50	8.30 (2.90-8.80)	2180 (550-2616)	3.81	A	2.00 + 2.00 + 2.50 + 4.30	10.80 (3.00-11.30)	2890 (540-3468)	3.74	A
15 + 15 + 18 + 50	1.30 + 1.30 + 1.56 + 4.34	8.50 (2.90-9.00)	2600 (550-3120)	3.27	A	1.69 + 1.69 + 2.12 + 5.50	11.00 (3.00-11.50)	2800 (540-3360)	3.93	A
15 + 15 + 25 + 25	1.50 + 1.50 + 2.50 + 2.50	8.00 (2.90-8.50)	2150 (550-2580)	3.72	A	2.00 + 2.00 + 3.40 + 3.40	10.80 (3.00-11.30)	2850 (540-3420)	3.79	A
15 + 15 + 25 + 35	1.42 + 1.42 + 2.36 + 3.31	8.50 (2.90-9.00)	2600 (550-3120)	3.27	A	1.88 + 1.88 + 3.20 + 4.04	11.00 (3.00-11.50)	2800 (540-3360)	3.93	A
15 + 15 + 25 + 50	1.21 + 1.21 + 2.02 + 4.05	8.50 (2.90-9.00)	2600 (550-3120)	3.27	A	1.58 + 1.58 + 2.69 + 5.14	11.00 (3.00-11.50)	2800 (540-3360)	3.93	A
15 + 15 + 35 + 35	1.28 + 1.28 + 2.975 + 2.98	8.50 (2.90-9.00)	2600 (550-3120)	3.27	A	1.75 + 1.75 + 3.75 + 3.75	11.00 (3.00-11.50)	2900 (540-3480)	3.79	A
15 + 15 + 35 + 50	1.11 + 1.11 + 2.59 + 3.70	8.50 (2.90-9.00)	2600 (550-3120)	3.27	A	1.49 + 1.49 + 3.20 + 4.83	11.00 (3.00-11.50)	2800 (540-3360)	3.93	A
15 + 15 + 50 + 50	0.98 + 0.98 + 3.27 + 3.27	8.50 (2.90-9.00)	2600 (550-3120)	3.27	A	1.29 + 1.29 + 4.21 + 4.21	11.00 (3.00-11.50)	2800 (540-3360)	3.93	A
15 + 18 + 18 + 18	1.50 + 1.80 + 1.80 + 1.80	6.90 (2.90-7.40)	1870 (550-2244)	3.69	A	2.00 + 2.50 + 2.50 + 2.50	9.50 (3.00-10.00)	2620 (540-3144)	3.63	A
15 + 18 + 18 + 25	1.50 + 1.80 + 1.80 + 2.50	7.60 (2.90-8.10)	2140 (550-2568)	3.55	A	2.00 + 2.50 + 2.50 + 3.40	10.40 (3.00-10.90)	2890 (540-3468)	3.60	B
15 + 18 + 18 + 35	1.48 + 1.78 + 1.78 + 3.46	8.50 (2.90-9.00)	2550 (550-3060)	3.33	A	1.95 + 2.43 + 2.43 + 4.19	11.00 (3.00-11.50)	2800 (540-3360)	3.93	A
15 + 18 + 18 + 50	1.26 + 1.51 + 1.51 + 4.21	8.50 (2.90-9.00)	2600 (550-3120)	3.27	A	1.63 + 2.04 + 2.04 + 5.30	11.00 (3.00-11.50)	2800 (540-3360)	3.93	A
15 + 18 + 25 + 25	1.50 + 1.80 + 2.50 + 2.50	8.30 (2.90-8.80)	2740 (550-3288)	3.03	B	1.95 + 2.43 + 3.31 + 3.31	11.00 (3.00-11.50)	2800 (540-3360)	3.93	A
15 + 18 + 25 + 35	1.37 + 1.65 + 2.28 + 3.20	8.50 (2.90-9.00)	2600 (550-3120)	3.27	A	1.80 + 2.25 + 3.07 + 3.88	11.00 (3.00-11.50)	2800 (540-3360)	3.93	A
15 + 18 + 25 + 50	1.18 + 1.42 + 1.97 + 3.94	8.50 (2.90-9.00)	2600 (550-3120)	3.27	A	1.53 + 1.91 + 2.60 + 4.97	11.00 (3.00-11.50)	2800 (540-3360)	3.93	A
15 + 18 + 35 + 35	1.24 + 1.49 + 2.89 + 2.89	8.50 (2.90-9.00)	2600 (550-3120)	3.27	A	1.68 + 2.10 + 3.61 + 3.61	11.00 (3.00-11.50)	2800 (540-3360)	3.93	A
15 + 18 + 35 + 50	1.08 + 1.30 + 2.52 + 3.60	8.50 (2.90-9.00)	2600 (550-3120)	3.27	A	1.44 + 1.80 + 3.09 + 4.67	11.00 (3.00-11.50)	2800 (540-3360)	3.93	A
15 + 18 + 50 + 50	0.96 + 1.15 + 3.20 + 3.20	8.50 (2.90-9.00)	2600 (550-3120)	3.27	A	1.26 + 1.57 + 4.09 + 4.09	11.00 (3.00-11.50)	2800 (540-3360)	3.93	A
15 + 25 + 25 + 25	1.42 + 2.36 + 2.36 + 2.36	8.50 (2.90-9.00)	2610 (550-3132)	3.26	A	1.80 + 3.07 + 3.07 + 3.07	11.00 (3.00-11.50)	2800 (540-3360)	3.93	A
15 + 25 + 25 + 35	1.28 + 2.13 + 2.13 + 2.98	8.50 (2.90-9.00)	2600 (550-3120)	3.27	A	1.68 + 2.85 + 2.85 + 3.61	11.00 (3.00-11.50)	2800 (540-3360)	3.93	A
15 + 25 + 25 + 50	1.11 + 1.85 + 1.85 + 3.67	8.50 (2.90-9.00)	2600 (550-3120)	3.27	A	1.44 + 2.44 + 2.44 + 4.67	11.00 (3.00-11.50)	2800 (540-3360)	3.93	A
15 + 25 + 35 + 35	1.16 + 1.93 + 2.70 + 2.70	8.50 (2.90-9.00)	2600 (550-3120)	3.27	A	1.57 + 2.67 + 3.38 + 3.38	11.00 (3.00-11.50)	2800 (540-3360)	3.93	A
15 + 25 + 35 + 50	1.02 + 1.70 + 2.38 + 3.40	8.50 (2.90-9.00)	2600 (550-3120)	3.27	A	1.36 + 2.31 + 2.92 + 4.41	11.00 (3.00-11.50)	2800 (540-3360)	3.93	A
15 + 25 + 50 + 50	0.91 + 1.52 + 3.04 + 3.04	8.50 (2.90-9.00)	2600 (550-3120)	3.27	A	1.20 + 2.03 + 3.89 + 3.89	11.00 (3.00-11.50)	2800 (540-3360)	3.93	A
15 + 35 + 35 + 35	1.06 + 2.48 + 2.48 + 2.48	8.50 (2.90-9.00)	2600 (550-3120)	3.27	A	1.48 + 3.17 + 3.17 + 3.17	11.00 (3.00-11.50)	2800 (540-3360)	3.93	A
15 + 35 + 35 + 50	0.94 + 2.20 + 2.20 + 3.15	8.50 (2.90-9.00)	2600 (550-3120)	3.27	A	1.29 + 2.77 + 2.77 + 4.18	11.00 (3.00-11.50)	2800 (540-3360)	3.93	A
15 + 35 + 50 + 50	0.85 + 1.98 + 2.83 + 2.83	8.50 (2.90-9.00)	2600 (550-3120)	3.27	A	1.14 + 2.45 + 3.70 + 3.70	11.00 (3.00-11.50)	2800 (540-3360)	3.93	A
18 + 18 + 18 + 18	1.80 + 1.80 + 1.80 + 1.80	7.20 (2.90-7.90)	1800 (550-2310)	4.00	A	2.40 + 2.40 + 2.40 + 2.40	9.60 (3.00-10.90)	2400 (540-2720)	4.00	A
18 + 18 + 18 + 25	1.80 + 1.80 + 1.80 + 2.50	7.90 (2.90-8.70)	2090 (550-2690)	3.78	A	2.25 + 2.25 + 2.25 + 3.06	9.80 (3.00-11.10)	2700 (540-3050)	3.63	A
18 + 18 + 18 + 35	1.72 + 1.72 + 1.72 + 3.34	8.50 (2.90-9.80)	2415 (550-3260)	3.52	A	2.16 + 2.16 + 2.16 + 3.72	10.20 (3.00-11.40)	2700 (540-3020)	3.78	A
18 + 18 + 18 + 50	1.46 + 1.46 + 1.46 + 4.11	8.50 (2.90-9.90)	2390 (550-3260)	3.56	A	1.82 + 1.81 + 1.81 + 4.76	10.20 (3.00-11.40)	2700 (540-3020)	3.78	A
18 + 18 + 25 + 25	1.78 + 1.78 + 2.47 + 2.47	8.50 (2.90-9.50)	2320 (550-3040)	3.66	A	2.12 + 2.12 + 2.88 + 2.88	10.00 (3.00-11.20)	2700 (540-3030)	3.70	A
18 + 18 + 25 + 35	1.59 + 1.59 + 2.21 + 3.10	8.50 (2.90-9.90)	2390 (550-3260)	3.56	A	2.01 + 2.01 + 2.73 + 3.45	10.20 (3.00-11.40)	2700 (540-3020)	3.78	A
18 + 18 + 25 + 50	1.37 + 1.37 + 1.90 + 3.88	8.50 (2.90-9.90)	2390 (550-3260)	3.56	A	1.71 + 1.70 + 2.32 + 4.50	10.20 (3.00-11.40)	2700 (540-3020)	3.78	A
18 + 18 + 35 + 35	1.44 + 1.44 + 2.81 + 2.81	8.50 (2.90-9.90)	2390 (550-3260)	3.56	A	1.88 + 1.88 + 3.23 + 3.23	10.20 (3.00-11.40)	2700 (540-3020)	3.78	A
18 + 18 + 35 + 50	1.27 + 1.27 + 2.46 + 3.49	8.50 (2.90-9.90)	2390 (550-3260)	3.56	A	1.61 + 1.62 + 2.78 + 4.18	10.20 (3.00-11.40)	2700 (540-3020)	3.78	A
18 + 18 + 50 + 50	1.14 + 1.14 + 3.12 + 3.12	8.50 (2.90-9.90)	2370 (550-3230)	3.59	A	1.44 + 1.45 + 3.75 + 3.75	10.40 (3.00-11.60)	2700 (540-3010)	3.85	A
18 + 25 + 25 + 25	1.71 + 2.26 + 2.26 + 2.26	8.50 (2.90-9.90)	2390 (550-3260)	3.56	A	2.01 + 2.71 + 2.71 + 2.71	10.20 (3.00-11.40)	2700 (540-3020)	3.78	A
18 + 25 + 25 + 35	1.52 + 2.08 + 2.08 + 2.83	8.50 (2.90-9.90)	2390 (550-3260)	3.56	A	1.88 + 2.57 + 2.57 + 3.17	10.20 (3.00-11.40)	2700 (540-3020)	3.78	A
18 + 25 + 25 + 50	1.33 + 1.79 + 1.79 + 3.59	8.50 (2.90-9.90)	2390 (550-3260)	3.56	A	1.61 + 2.18 + 2.18 + 4.19	10.20 (3.00-11.40)	2700 (540-3020)	3.78	A
18 + 25 + 35 + 35	1.32 + 1.89 + 2.64 + 2.64	8.50 (2.90-9.90)	2390 (550-3260)	3.56	A	1.76 + 2.40 + 3.03 + 3.03	10.20 (3.00-11.40)	2700 (540-3020)	3.78	A
18 + 25 + 35 + 50	1.23 + 1.65 + 2.31 + 3.30	8.50 (2.90-9.90)	2390 (550-3260)	3.56	A	1.53 + 2.07 + 2.62 + 3.95	10.20 (3.00-11.40)	2700 (540-3020)	3.78	A
18 + 25 + 50 + 50	1.09 + 1.47 + 2.97 + 2.97	8.50 (2.90-9.90)	2370 (550-3230)	3.59	A	1.46 + 1.96 + 3.78 + 3.78	11.00 (3.00-12.10)	2630 (540-2890)	4.18	A
18 + 35 + 35 + 35	1.27 + 2.41 + 2.41 + 2.41	8.50 (2.90-9.90)	2390 (550-3260)	3.56	A	1.66 + 2.84 + 2.84 + 2.84	10.20 (3.00-11.40)	2700 (540-3020)	3.78	A

4 UNITS

POSSIBLE COMBINATIONS OF INDOOR UNITS	COOLING MODE					HEATING MODE					
	Unit power (kW)	Total power (kW)	Total Abs. power (W)	EER	Energy class	Unit power (kW)	Total power (kW)	Total Abs. power (W)	COP	Energy class	
4 UNITS	18 + 35 + 35 + 50	1.09 + 2.18 + 2.18 + 3.07	8.50 (2.90-9.90)	2390 (550-3260)	3.56	A	1.56 + 2.71 + 2.71 + 4.05	11.00 (3.00-12.10)	2,800 (540-3080)	3.93	A
	18 + 35 + 50 + 50	0.99 + 1.93 + 2.79 + 2.79	8.50 (2.90-9.90)	2370 (550-3230)	3.59	A	1.39 + 2.38 + 3.62 + 3.62	11.00 (3.00-12.10)	2800 (540-2890)	3.93	A
	25 + 25 + 25 + 25	2.13 + 2.13 + 2.13 + 2.13	8.50 (2.90-9.90)	2370 (550-3260)	3.59	A	2.55 + 2.55 + 2.55 + 2.55	10.20 (3.00-11.40)	2700 (540-3020)	3.78	A
	25 + 25 + 25 + 35	1.93 + 1.93 + 1.93 + 2.69	8.50 (2.90-9.90)	2370 (550-3260)	3.59	A	2.39 + 2.39 + 2.39 + 3.01	10.20 (3.00-11.40)	2700 (540-3020)	3.78	A
	25 + 25 + 25 + 50	1.70 + 1.70 + 1.70 + 3.40	8.50 (2.90-9.90)	2370 (550-3260)	3.59	A	2.12 + 2.12 + 2.12 + 4.05	10.40 (3.00-11.60)	2700 (540-3010)	3.85	A
	25 + 25 + 35 + 35	1.77 + 1.77 + 2.47 + 2.47	8.50 (2.90-9.90)	2370 (550-3260)	3.59	A	1.76 + 2.39 + 3.01 + 3.01	10.20 (3.00-11.40)	2700 (540-3020)	3.78	A
	25 + 25 + 35 + 50	1.57 + 1.57 + 2.20 + 3.15	8.50 (2.90-9.90)	2370 (550-3260)	3.59	A	2.01 + 2.01 + 2.54 + 3.84	10.40 (3.00-11.60)	2700 (540-3010)	3.85	A
	25 + 25 + 50 + 50	1.42 + 1.42 + 2.83 + 2.83	8.50 (2.90-9.90)	2370 (550-3230)	3.59	A	1.89 + 1.89 + 3.61 + 3.61	11.00 (3.00-12.10)	2630 (540-2890)	4.18	A
	25 + 35 + 35 + 35	1.64 + 2.29 + 2.29 + 2.29	8.50 (2.90-9.90)	2390 (550-3260)	3.56	A	2.17 + 2.74 + 2.74 + 2.74	10.40 (3.00-11.60)	2700 (540-3010)	3.85	A
	25 + 35 + 35 + 50	1.48 + 2.05 + 2.05 + 2.93	8.50 (2.90-9.90)	2390 (550-3260)	3.56	A	2.02 + 2.56 + 2.56 + 3.86	11.00 (3.00-12.10)	2630 (540-2890)	4.18	A
	35 + 35 + 35 + 35	2.13 + 2.13 + 2.13 + 2.13	8.50 (2.90-9.90)	2390 (550-3260)	3.56	A	2.75 + 2.75 + 2.75 + 2.75	11.00 (3.00-12.10)	2630 (540-2890)	4.18	A
	35 + 35 + 35 + 50	1.92 + 1.92 + 1.92 + 2.74	8.50 (2.90-9.90)	2390 (550-3260)	3.56	A	2.44 + 2.44 + 2.44 + 3.69	11.00 (3.00-12.10)	2630 (540-2890)	4.18	A
5 UNITS	15 + 15 + 15 + 15 + 15	1.50 + 1.50 + 1.50 + 1.50 + 1.50	7.50 (3.20-8.00)	1770 (600-2124)	4.24	A	2.00 + 2.00 + 2.00 + 2.00 + 2.00	10.00 (3.40-10.50)	2350 (610-2820)	4.26	A
	15 + 15 + 15 + 15 + 18	1.50 + 1.50 + 1.50 + 1.50 + 1.80	7.80 (3.20-8.30)	1850 (600-2220)	4.22	A	2.00 + 2.00 + 2.00 + 2.00 + 2.50	10.50 (3.40-11.00)	2360 (610-2832)	4.45	A
	15 + 15 + 15 + 15 + 25	1.50 + 1.50 + 1.50 + 1.50 + 2.50	8.50 (3.20-9.00)	1950 (600-2340)	4.36	A	1.93 + 1.93 + 1.93 + 1.93 + 3.28	11.00 (3.40-11.50)	2400 (610-2880)	4.58	A
	15 + 15 + 15 + 15 + 35	1.34 + 1.34 + 1.34 + 1.34 + 3.13	8.50 (3.20-9.00)	2590 (600-3108)	3.28	A	1.79 + 1.79 + 1.79 + 1.79 + 3.85	11.00 (3.40-11.50)	2460 (610-2952)	4.47	A
	15 + 15 + 15 + 15 + 50	1.16 + 1.16 + 1.16 + 1.16 + 3.86	8.50 (3.20-9.00)	2390 (600-2868)	3.56	A	1.52 + 1.52 + 1.52 + 1.52 + 4.93	11.00 (3.40-11.50)	2460 (610-2952)	4.47	A
	15 + 15 + 15 + 18 + 18	1.50 + 1.50 + 1.50 + 1.80 + 1.80	8.10 (3.20-8.60)	1960 (600-2352)	4.13	A	2.00 + 2.00 + 2.00 + 2.50 + 2.50	11.00 (3.40-11.50)	2460 (610-2952)	4.47	A
	15 + 15 + 15 + 18 + 25	1.45 + 1.45 + 1.45 + 1.74 + 2.41	8.50 (3.20-9.00)	2200 (600-2640)	3.86	A	1.85 + 1.85 + 1.85 + 2.31 + 3.14	11.00 (3.40-11.50)	2460 (610-2952)	4.47	A
	15 + 15 + 15 + 18 + 35	1.30 + 1.30 + 1.30 + 1.56 + 3.04	8.50 (3.20-9.00)	2390 (600-2868)	3.56	A	1.72 + 1.72 + 1.72 + 2.15 + 3.70	11.00 (3.40-11.50)	2460 (610-2952)	4.47	A
	15 + 15 + 15 + 18 + 50	1.13 + 1.13 + 1.13 + 1.35 + 3.76	8.50 (3.20-9.00)	2390 (600-2868)	3.56	A	1.47 + 1.47 + 1.47 + 1.83 + 4.77	11.00 (3.40-11.50)	2460 (610-2952)	4.47	A
	15 + 15 + 15 + 25 + 25	1.34 + 1.34 + 1.34 + 2.24 + 2.24	8.50 (3.20-9.00)	2480 (600-2976)	3.43	A	1.72 + 1.72 + 1.72 + 2.92 + 2.92	11.00 (3.40-11.50)	2460 (610-2952)	4.47	A
	15 + 15 + 15 + 25 + 35	1.21 + 1.21 + 1.21 + 2.02 + 2.83	8.50 (3.20-9.00)	2390 (600-2868)	3.56	A	1.61 + 1.61 + 1.61 + 2.73 + 3.45	11.00 (3.40-11.50)	2460 (610-2952)	4.47	A
	15 + 15 + 15 + 25 + 50	1.06 + 1.06 + 1.06 + 1.77 + 3.54	8.50 (3.20-9.00)	2390 (600-2868)	3.56	A	1.38 + 1.38 + 1.38 + 2.35 + 4.50	11.00 (3.40-11.50)	2460 (610-2952)	4.47	A
	15 + 15 + 15 + 35 + 35	1.11 + 1.11 + 1.11 + 2.59 + 2.59	8.50 (3.20-9.00)	2390 (600-2868)	3.56	A	1.51 + 1.51 + 1.51 + 3.24 + 3.24	11.00 (3.40-11.50)	2460 (610-2952)	4.47	A
	15 + 15 + 15 + 35 + 50	0.98 + 0.98 + 0.98 + 2.29 + 3.27	8.50 (3.20-9.00)	2390 (600-2868)	3.56	A	1.31 + 1.31 + 1.31 + 2.82 + 4.26	11.00 (3.40-11.50)	2460 (610-2952)	4.47	A
	15 + 15 + 15 + 50 + 50	0.88 + 0.88 + 0.88 + 2.93 + 2.93	8.50 (3.20-9.00)	2390 (600-2868)	3.56	A	1.16 + 1.16 + 1.16 + 3.76 + 3.76	11.00 (3.40-11.50)	2460 (610-2952)	4.47	A
	15 + 15 + 18 + 18 + 18	1.50 + 1.50 + 1.80 + 1.80 + 1.80	8.40 (3.20-8.90)	2180 (600-2616)	3.85	A	1.91 + 1.91 + 2.39 + 2.39 + 2.39	11.00 (3.40-11.50)	2460 (610-2952)	4.47	A
	15 + 15 + 18 + 18 + 25	1.40 + 1.40 + 1.68 + 1.68 + 2.34	8.50 (3.20-9.00)	2490 (600-2988)	3.41	A	1.77 + 1.77 + 2.22 + 2.22 + 3.02	11.00 (3.40-11.50)	2460 (610-2952)	4.47	A
	15 + 15 + 18 + 18 + 35	1.26 + 1.26 + 1.51 + 1.51 + 2.95	8.50 (3.20-9.00)	2390 (600-2868)	3.56	A	1.65 + 1.65 + 2.07 + 2.07 + 3.56	11.00 (3.40-11.50)	2460 (610-2952)	4.47	A
	15 + 15 + 18 + 18 + 50	1.10 + 1.10 + 1.32 + 1.32 + 3.66	8.50 (3.20-9.00)	2390 (600-2868)	3.56	A	1.42 + 1.42 + 1.77 + 1.77 + 4.61	11.00 (3.40-11.50)	2460 (610-2952)	4.47	A
	15 + 15 + 18 + 25 + 25	1.30 + 1.30 + 1.56 + 2.17 + 2.17	8.50 (3.20-9.00)	2390 (600-2868)	3.56	A	1.65 + 1.65 + 2.07 + 2.81 + 2.81	11.00 (3.40-11.50)	2460 (610-2952)	4.47	A
	15 + 15 + 18 + 25 + 35	1.18 + 1.18 + 1.42 + 1.97 + 2.75	8.50 (3.20-9.00)	2390 (600-2868)	3.56	A	1.55 + 1.55 + 1.94 + 2.63 + 3.33	11.00 (3.40-11.50)	2460 (610-2952)	4.47	A
	15 + 15 + 18 + 25 + 50	1.04 + 1.04 + 1.24 + 1.73 + 3.46	8.50 (3.20-9.00)	2390 (600-2868)	3.56	A	1.34 + 1.34 + 1.68 + 2.28 + 4.36	11.00 (3.40-11.50)	2460 (610-2952)	4.47	A
	15 + 15 + 18 + 35 + 35	1.08 + 1.08 + 1.30 + 2.52 + 2.52	8.50 (3.20-9.00)	2390 (600-2868)	3.56	A	1.46 + 1.46 + 1.82 + 3.13 + 3.13	11.00 (3.40-11.50)	2460 (610-2952)	4.47	A
	15 + 15 + 18 + 35 + 50	0.96 + 0.96 + 1.15 + 2.24 + 3.20	8.50 (3.20-9.00)	2390 (600-2868)	3.56	A	1.27 + 1.27 + 1.59 + 2.73 + 4.13	11.00 (3.40-11.50)	2460 (610-2952)	4.47	A
	15 + 15 + 18 + 50 + 50	0.86 + 0.86 + 1.03 + 2.87 + 2.87	8.50 (3.20-9.00)	2390 (600-2868)	3.56	A	1.13 + 1.13 + 1.41 + 3.67 + 3.67	11.00 (3.40-11.50)	2460 (610-2952)	4.47	A
	15 + 15 + 25 + 25 + 25	1.21 + 1.21 + 2.02 + 2.02 + 2.02	8.50 (3.20-9.00)	2390 (600-2868)	3.56	A	1.55 + 1.55 + 2.63 + 2.63 + 2.63	11.00 (3.40-11.50)	2460 (610-2952)	4.47	A
	15 + 15 + 25 + 25 + 35	1.11 + 1.11 + 1.85 + 1.85 + 2.59	8.50 (3.20-9.00)	2390 (600-2868)	3.56	A	1.46 + 1.46 + 2.48 + 2.48 + 3.13	11.00 (3.40-11.50)	2460 (610-2952)	4.47	A
	15 + 15 + 25 + 25 + 50	0.98 + 0.98 + 1.63 + 1.63 + 3.27	8.50 (3.20-9.00)	2390 (600-2868)	3.56	A	1.27 + 1.27 + 2.16 + 2.16 + 4.13	11.00 (3.40-11.50)	2460 (610-2952)	4.47	A
	15 + 15 + 25 + 35 + 35	1.02 + 1.02 + 1.7 + 2.38 + 2.38	8.50 (3.20-9.00)	2390 (600-2868)	3.56	A	1.38 + 1.38 + 2.34 + 2.96 + 2.96	11.00 (3.40-11.50)	2460 (610-2952)	4.47	A
	15 + 15 + 25 + 35 + 50	0.91 + 0.91 + 1.52 + 2.13 + 3.04	8.50 (3.20-9.00)	2390 (600-2868)	3.56	A	1.21 + 1.21 + 2.05 + 2.60 + 3.93	11.00 (3.40-11.50)	2460 (610-2952)	4.47	A
	15 + 15 + 25 + 50 + 50	0.82 + 0.82 + 1.37 + 2.74 + 2.74	8.50 (3.20-9.00)	2390 (600-2868)	3.56	A	1.08 + 1.08 + 1.83 + 3.50 + 3.50	11.00 (3.40-11.50)	2460 (610-2952)	4.47	A
	15 + 15 + 35 + 35 + 35	0.94 + 0.94 + 2.20 + 2.20 + 2.20	8.50 (3.20-9.00)	2390 (600-2868)	3.56	A	1.30 + 1.30 + 2.80 + 2.80 + 2.80	11.00 (3.40-11.50)	2460 (610-2952)	4.47	A
	15 + 15 + 35 + 35 + 50	0.85 + 0.85 + 1.98 + 1.98 + 2.83	8.50 (3.20-9.00)	2390 (600-2868)	3.56	A	1.15 + 1.15 + 2.48 + 2.48 + 3.74	11.00 (3.40-11.50)	2460 (610-2952)	4.47	A
	15 + 18 + 18 + 18 + 18	1.47 + 1.76 + 1.76 + 1.76 + 1.76	8.50 (3.20-9.00)	2530 (600-3036)	3.36	A	1.83 + 2.29 + 2.29 + 2.29 + 2.29	11.00 (3.40-11.50)	2460 (610-2952)	4.47	A
	15 + 18 + 18 + 18 + 25	1.36 + 1.63 + 1.63 + 1.63 + 2.26	8.50 (3.20-9.00)	2390 (600-2868)	3.56	A	1.71 + 2.13 + 2.13 + 2.13 + 2.90	11.00 (3.40-11.50)	2460 (610-2952)	4.47	A
	15 + 18 + 18 + 18 + 35	1.23 + 1.47 + 1.47 + 1.47 + 2.86	8.50 (3.20-9.00)	2390 (600-2868)	3.56	A	1.59 + 1.99 + 1.99 + 1.99 + 3.43	11.00 (3.40-11.50)	2460 (610-2952)	4.47	A
15 + 18 + 18 + 18 + 50	1.07 + 1.29 + 1.29 + 1.29 + 3.57	8.50 (3.20-9.00)	2390 (600-2868)	3.56	A	1.38 + 1.72 + 1.72 + 1.72 + 4.47	11.00 (3.40-11.50)	2460 (610-2952)	4.47	A	
15 + 18 + 18 + 25 + 25	1.26 + 1.51 + 1.51 + 2.10 + 2.10	8.50 (3.20-9.00)	2390 (600-2868)	3.56	A	1.59 + 1.99 + 1.99 + 2.71 + 2.71	11.00 (3.40-11.50)	2460 (610-2952)	4.47	A	
15 + 18 + 18 + 25 + 35	1.15 + 1.38 + 1.38 + 1.91 + 2.68	8.50 (3.20-9.00)	2390 (600-2868)	3.56	A	1.50 + 1.87 + 1.87 + 2.54 + 3.22	11.00 (3.40-11.50)	2460 (610-2952)	4.47	A	
15 + 18 + 18 + 25 + 50	1.01 + 1.21 + 1.21 + 1.69 + 3.37	8.50 (3.20-9.00)	2390 (600-2868)	3.56	A	1.30 + 1.63 + 1.63 + 2.21 + 4.23	11.00 (3.40-11.50)	2460 (610-2952)	4.47	A	
15 + 18 + 18 + 35 + 35	1.05 + 1.26 + 1.26 + 2.46 + 2.46	8.50 (3.20-9.00)	2390 (600-2868)	3.56	A	1.41 + 1.76 + 1.76 + 3.03 + 3.03	11.00 (3.40-11.50)	2460 (610-2952)	4.47	A	
15 + 18 + 18 + 35 + 50	0.94 + 1.13 + 1.13 + 2.19 + 3.13	8.50 (3.20-9.00)	2390 (600-2868)	3.56	A	1.24 + 1.54 + 1.54 + 2.66 + 4.02	11.00 (3.40-11.50)	2460 (610-2952)	4.47	A	
15 + 18 + 18 + 50 + 50	0.84 + 1.01 + 1.01 + 2.81 + 2.81	8.50 (3.20-9.00)	2390 (600-2868)	3.56	A	1.10 + 1.38 + 1.38 + 3.58 + 3.58	11.00 (3.40-11.50)	2460 (610-2952)	4.47	A	
15 + 18 + 25 + 25 + 25	1.18 + 1.42 + 1.97 + 1.97 + 1.97	8.50 (3.20-9.00)	2390 (600-2868)	3.56	A	1.50 + 1.87 + 2.54 + 2.54 + 2.54	11.00 (3.40-11.50)	2460 (610-2952)	4.47	A	

POSSIBLE COMBINATIONS OF INDOOR UNITS	COOLING MODE					HEATING MODE				
	Unit power (kW)	Total power (kW)	Total Abs. power (W)	EER	Energy class	Unit power (kW)	Total power (kW)	Total Abs. power (W)	COP	Energy class
15 + 18 + 25 + 25 + 35	1.08 + 1.30 + 1.80 + 1.80 + 2.52	8.50 (3.20-9.00)	2390 (600-2868)	3.56	A	1.41 + 1.76 + 2.40 + 2.40 + 3.03	11.00 (3.40-11.50)	2460 (610-2952)	4.47	A
15 + 18 + 25 + 25 + 50	0.96 + 1.15 + 1.60 + 1.60 + 3.20	8.50 (3.20-9.00)	2390 (600-2868)	3.56	A	1.24 + 1.54 + 2.10 + 2.10 + 4.02	11.00 (3.40-11.50)	2460 (610-2952)	4.47	A
15 + 18 + 25 + 35 + 35	1.00 + 1.20 + 1.66 + 2.32 + 2.32	8.50 (3.20-9.00)	2390 (600-2868)	3.56	A	1.33 + 1.67 + 2.27 + 2.87 + 2.87	11.00 (3.40-11.50)	2460 (610-2952)	4.47	A
15 + 18 + 25 + 35 + 50	0.89 + 1.07 + 1.49 + 2.08 + 2.97	8.50 (3.20-9.00)	2390 (600-2868)	3.56	A	1.18 + 1.47 + 2.00 + 2.53 + 3.82	11.00 (3.40-11.50)	2460 (610-2952)	4.47	A
15 + 18 + 35 + 35 + 35	0.92 + 1.11 + 2.16 + 2.16 + 2.16	8.50 (3.20-9.00)	2390 (600-2868)	3.56	A	1.26 + 1.58 + 2.72 + 2.72 + 2.72	11.00 (3.40-11.50)	2460 (610-2952)	4.47	A
15 + 18 + 35 + 35 + 50	0.83 + 1.00 + 1.94 + 1.94 + 2.78	8.50 (3.20-9.00)	2390 (600-2868)	3.56	A	1.12 + 1.40 + 2.41 + 2.41 + 3.65	11.00 (3.40-11.50)	2460 (610-2952)	4.47	A
18 + 18 + 18 + 18 + 18	1.70 + 1.70 + 1.70 + 1.70 + 1.70	8.50 (3.20-9.90)	2230 (600-3040)	3.81	A	2.20 + 2.20 + 2.20 + 2.20 + 2.20	11.00 (3.40-12.10)	2460 (610-2710)	4.47	A
18 + 18 + 18 + 18 + 25	1.58 + 1.58 + 1.58 + 1.58 + 2.19	8.50 (3.20-9.90)	2230 (600-3040)	3.81	A	2.05 + 2.05 + 2.05 + 2.05 + 2.79	11.00 (3.40-12.10)	2460 (610-2710)	4.47	A
18 + 18 + 18 + 18 + 35	1.43 + 1.43 + 1.43 + 1.43 + 2.80	8.50 (3.20-9.90)	2230 (600-3040)	3.81	A	1.92 + 1.92 + 1.92 + 1.92 + 3.33	11.00 (3.40-12.10)	2460 (610-2710)	4.47	A
18 + 18 + 18 + 18 + 50	1.25 + 1.25 + 1.25 + 1.25 + 3.47	8.50 (3.20-9.90)	2230 (600-3040)	3.81	A	1.67 + 1.67 + 1.67 + 1.67 + 4.32	11.00 (3.40-12.10)	2460 (610-2710)	4.47	A
18 + 18 + 18 + 25 + 25	1.47 + 1.47 + 1.47 + 2.04 + 2.04	8.50 (3.20-9.90)	2230 (600-3040)	3.81	A	1.92 + 1.92 + 1.92 + 2.62 + 2.62	11.00 (3.40-12.10)	2460 (610-2710)	4.47	A
18 + 18 + 18 + 25 + 35	1.34 + 1.34 + 1.34 + 1.86 + 2.62	8.50 (3.20-9.90)	2230 (600-3040)	3.81	A	1.81 + 1.81 + 1.81 + 2.46 + 3.12	11.00 (3.40-12.10)	2460 (610-2710)	4.47	A
18 + 18 + 18 + 25 + 50	1.19 + 1.19 + 1.19 + 1.65 + 3.28	8.50 (3.20-9.90)	2230 (600-3040)	3.81	A	1.58 + 1.58 + 1.58 + 2.15 + 4.10	11.00 (3.40-12.10)	2460 (610-2710)	4.47	A
18 + 18 + 18 + 35 + 35	1.22 + 1.22 + 1.22 + 2.41 + 2.41	8.50 (3.20-9.90)	2230 (600-3040)	3.81	A	1.71 + 1.70 + 1.70 + 2.95 + 2.95	11.00 (3.40-12.10)	2460 (610-2710)	4.47	A
18 + 18 + 18 + 35 + 50	1.10 + 1.10 + 1.10 + 2.14 + 3.04	8.50 (3.20-9.90)	2230 (600-3040)	3.81	A	1.50 + 1.50 + 1.50 + 2.58 + 3.89	11.00 (3.40-12.10)	2460 (610-2710)	4.47	A
18 + 18 + 18 + 50 + 50	1.00 + 1.00 + 1.00 + 2.75 + 2.75	8.50 (3.20-9.90)	2230 (600-3040)	3.81	A	1.34 + 1.34 + 1.34 + 3.49 + 3.49	11.00 (3.40-12.10)	2460 (610-2710)	4.47	A
18 + 18 + 25 + 25 + 25	1.39 + 1.39 + 1.90 + 1.90 + 1.90	8.50 (3.20-9.90)	2230 (600-3040)	3.81	A	1.81 + 1.81 + 2.45 + 2.45 + 2.45	11.00 (3.40-12.10)	2460 (610-2710)	4.47	A
18 + 18 + 25 + 25 + 35	1.26 + 1.26 + 1.76 + 1.76 + 2.46	8.50 (3.20-9.90)	2230 (600-3040)	3.81	A	1.71 + 1.71 + 2.32 + 2.32 + 2.94	11.00 (3.40-12.10)	2460 (610-2710)	4.47	A
18 + 18 + 25 + 25 + 50	1.13 + 1.13 + 1.56 + 1.56 + 3.14	8.50 (3.20-9.90)	2230 (600-3040)	3.81	A	1.50 + 1.50 + 2.04 + 2.04 + 3.92	11.00 (3.40-12.10)	2460 (610-2710)	4.47	A
18 + 18 + 25 + 35 + 35	1.17 + 1.17 + 1.62 + 2.27 + 2.27	8.50 (3.20-9.90)	2230 (600-3040)	3.81	A	1.62 + 1.62 + 2.20 + 2.78 + 2.78	11.00 (3.40-12.10)	2460 (610-2710)	4.47	A
18 + 18 + 25 + 35 + 50	1.05 + 1.05 + 1.46 + 2.04 + 2.91	8.50 (3.20-9.90)	2230 (600-3040)	3.81	A	1.43 + 1.43 + 1.95 + 2.46 + 3.72	11.00 (3.40-12.10)	2460 (610-2710)	4.47	A
18 + 18 + 35 + 35 + 35	1.11 + 1.11 + 2.10 + 2.10 + 2.10	8.50 (3.20-9.90)	2230 (600-3040)	3.81	A	1.54 + 1.56 + 2.63 + 2.63 + 2.63	11.00 (3.40-12.10)	2460 (610-2710)	4.47	A
18 + 25 + 25 + 25 + 25	1.29 + 1.80 + 1.80 + 1.80 + 1.80	8.50 (3.20-9.90)	2230 (600-3040)	3.81	A	1.80 + 2.30 + 2.30 + 2.30 + 2.30	11.00 (3.40-12.10)	2460 (610-2710)	4.47	A
18 + 25 + 25 + 25 + 35	1.19 + 1.66 + 1.66 + 1.66 + 2.32	8.50 (3.20-9.90)	2230 (600-3040)	3.81	A	1.60 + 2.20 + 2.20 + 2.20 + 2.80	11.00 (3.40-12.10)	2460 (610-2710)	4.47	A
18 + 25 + 25 + 25 + 50	1.08 + 1.49 + 1.49 + 1.49 + 2.97	8.50 (3.20-9.90)	2230 (600-3040)	3.81	A	1.45 + 1.95 + 1.95 + 1.95 + 3.70	11.00 (3.40-12.10)	2460 (610-2710)	4.47	A
18 + 25 + 25 + 35 + 35	1.12 + 1.54 + 1.54 + 2.16 + 2.16	8.50 (3.20-9.90)	2230 (600-3040)	3.81	A	1.54 + 2.09 + 2.09 + 2.64 + 2.64	11.00 (3.40-12.10)	2460 (610-2710)	4.47	A
18 + 25 + 25 + 35 + 50	1.00 + 1.39 + 1.39 + 1.94 + 2.78	8.50 (3.20-9.90)	2230 (600-3040)	3.81	A	1.37 + 1.86 + 1.86 + 2.35 + 3.56	11.00 (3.40-12.10)	2460 (610-2710)	4.47	A
18 + 25 + 35 + 35 + 35	1.03 + 1.44 + 2.01 + 2.01 + 2.01	8.50 (3.20-9.90)	2230 (600-3040)	3.81	A	1.45 + 1.99 + 2.55 + 2.55 + 2.55	11.00 (3.40-12.10)	2460 (610-2710)	4.47	A
25 + 25 + 25 + 25 + 25	1.70 + 1.70 + 1.70 + 1.70 + 1.70	8.50 (3.20-9.90)	2230 (600-3040)	3.81	A	2.20 + 2.20 + 2.20 + 2.20 + 2.20	11.00 (3.40-12.10)	2460 (610-2710)	4.47	A
25 + 25 + 25 + 25 + 35	1.57 + 1.57 + 1.57 + 1.57 + 2.19	8.50 (3.20-9.90)	2230 (600-3040)	3.81	A	2.09 + 2.09 + 2.09 + 2.09 + 2.64	11.00 (3.40-12.10)	2460 (610-2710)	4.47	A
25 + 25 + 25 + 25 + 50	1.42 + 1.42 + 1.42 + 1.42 + 2.83	8.50 (3.20-9.90)	2230 (600-3040)	3.81	A	1.86 + 1.86 + 1.86 + 1.86 + 3.56	11.00 (3.40-12.10)	2460 (610-2710)	4.47	A
25 + 25 + 25 + 35 + 35	1.48 + 1.48 + 1.48 + 2.04 + 2.04	8.50 (3.20-9.90)	2230 (600-3040)	3.81	A	2.00 + 2.00 + 2.00 + 2.50 + 2.50	11.00 (3.40-12.10)	2460 (610-2710)	4.47	A
25 + 25 + 35 + 35 + 35	1.39 + 1.39 + 1.91 + 1.91 + 1.91	8.50 (3.20-9.90)	2230 (600-3040)	3.81	A	1.90 + 1.90 + 2.40 + 2.40 + 2.40	11.00 (3.40-12.10)	2460 (610-2710)	4.47	A

### RAM-90NP5B ▲ FRIGORIFIC LENGTHS

(L1+L2+L3+L4+L5) = max 75 m.  
 L1 = 25 m ; L2 = 25 m ; L3 = 25 m ; L4 = 25 m ; L5 = 25 m  
 Maximum height between the highest indoor unit and the lowest indoor unit: 5m.  
 Preload for 30 m.  
 Provide 15 g/m of refrigerant beyond 30 m.  
 Always connect the most powerful indoor unit to the lowest connection.  
 Connection 3 is intended for indoor units 18, 25 or 35, if not, provide a 0.95-1.27 adapter.

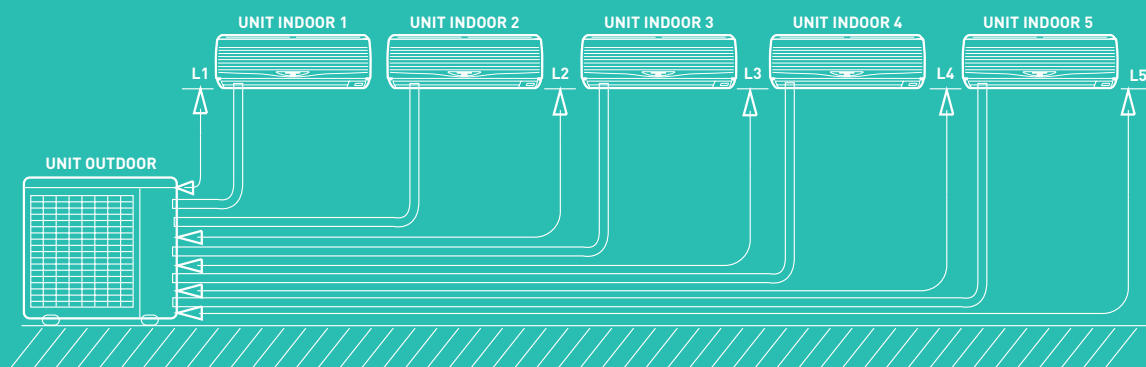



## MULTIZONE COMBINATIONS

# RAM-110NP6B

POSSIBLE COMBINATIONS OF INDOOR UNITS	COOLING MODE					HEATING MODE				
	Unit power (kW)	Total power (kW)	Total Abs. power (W)	EER	Energy class	Unit power (kW)	Total power (kW)	Total Abs. power (W)	COP	Energy class
15 + 15	1.50 + 1.50	3.00 (1.50-3.90)	920 (200-1000)	3.26	A	2.00 + 2.00	4.00 (1.50-4.70)	1060 (200-1380)	3.77	A
15 + 18	1.50 + 1.80	3.30 (1.50-3.90)	1020 (200-1300)	3.24	A	2.00 + 2.50	4.50 (1.50-5.20)	1250 (200-1870)	3.60	A
15 + 25	1.50 + 2.50	4.00 (1.50-4.50)	1180 (200-1250)	3.39	A	2.00 + 3.90	5.90 (1.50-6.50)	1620 (200-2010)	3.64	A
15 + 35	1.50 + 3.50	5.00 (1.50-5.90)	1480 (200-1660)	3.38	A	2.00 + 4.80	6.80 (1.50-7.20)	1820 (200-2010)	3.74	A
15 + 50	1.22 + 4.08	5.30 (1.50-5.90)	1550 (200-1660)	3.42	A	1.60 + 5.20	6.80 (1.50-7.20)	1820 (200-2010)	3.74	A
18 + 18	1.80 + 1.80	3.60 (1.50-4.00)	1080 (200-1300)	3.33	A	2.50 + 2.50	5.00 (1.50-5.20)	1290 (200-1550)	3.88	A
18 + 25	1.80 + 2.50	4.30 (1.50-4.60)	1280 (200-1450)	3.36	A	2.50 + 3.90	6.40 (1.50-6.30)	1700 (200-1920)	3.76	A
18 + 35	1.80 + 3.50	5.30 (1.50-5.60)	1550 (200-1660)	3.42	A	2.33 + 4.47	6.80 (1.50-7.20)	1850 (200-2010)	3.68	A
18 + 50	1.40 + 3.90	5.30 (1.50-5.90)	1550 (200-1660)	3.42	A	1.80 + 5.00	6.80 (1.50-7.20)	1820 (200-2010)	3.74	A
25 + 25	2.50 + 2.50	5.00 (1.50-5.60)	1470 (200-1660)	3.40	A	3.40 + 3.40	6.80 (1.50-7.20)	1820 (200-2010)	3.74	A
25 + 35	2.21 + 3.09	5.30 (1.50-5.70)	1550 (200-1660)	3.42	A	2.83 + 3.97	6.80 (1.50-7.20)	1820 (200-2010)	3.74	A
35 + 35	2.65 + 2.65	5.30 (1.50-5.90)	1550 (200-1660)	3.42	A	3.40 + 3.40	6.80 (1.50-7.20)	1790 (200-2010)	3.80	A
25 + 50	1.77 + 3.53	5.30 (1.50-5.90)	1550 (200-1660)	3.42	A	2.55 + 4.25	6.80 (1.50-7.20)	1790 (200-2010)	3.80	A
35 + 50	2.18 + 3.12	5.30 (1.50-6.60)	1550 (200-1660)	3.42	A	2.89 + 3.91	6.80 (1.50-7.20)	1790 (200-2010)	3.80	A

Aparthotel Fuerteventura  
Multizone Range  
More info: [www.hitachiaircon.es](http://www.hitachiaircon.es)



POSSIBLE COMBINATIONS OF INDOOR UNITS	COOLING MODE					HEATING MODE				
	Unit power (kW)	Total power (kW)	Total Abs. power (W)	EER	Energy class	Unit power (kW)	Total power (kW)	Total Abs. power (W)	COP	Energy class
15 + 15 + 15	1.50 + 1.50 + 1.50	4.50 (1.50~5.00)	1320 (200~1680)	3.41	A	2.00 + 2.00 + 2.00	6.00 (1.50~6.20)	1580 (200~1550)	3.80	A
15 + 15 + 18	1.50 + 1.50 + 1.80	4.80 (1.50~6.00)	1420 (200~1680)	3.38	A	2.00 + 2.00 + 2.50	6.50 (1.50~6.60)	1620 (200~1760)	4.01	A
15 + 15 + 25	1.45 + 1.45 + 2.41	5.30 (1.50~6.00)	1550 (200~1660)	3.42	A	1.72 + 1.72 + 3.36	6.80 (1.50~7.20)	1680 (200~1860)	4.05	A
15 + 15 + 35	1.22 + 1.22 + 2.85	5.30 (1.50~6.00)	1550 (200~1680)	3.42	A	1.55 + 1.55 + 3.71	6.80 (1.50~7.20)	1680 (200~1860)	4.05	A
15 + 15 + 50	0.99 + 0.99 + 3.31	5.30 (1.50~6.00)	1550 (200~1680)	3.42	A	1.30 + 1.30 + 4.21	6.80 (1.50~7.20)	1680 (200~1860)	4.05	A
15 + 18 + 18	1.50 + 1.80 + 1.80	5.10 (1.50~6.00)	1500 (200~1660)	3.40	A	1.94 + 2.43 + 2.43	6.80 (1.50~7.20)	1680 (200~1860)	4.05	A
15 + 18 + 25	1.37 + 1.64 + 2.28	5.30 (1.50~6.00)	1550 (200~1680)	3.42	A	1.62 + 2.02 + 3.16	6.80 (1.50~7.20)	1680 (200~1860)	4.05	A
15 + 18 + 35	1.17 + 1.40 + 2.73	5.30 (1.50~6.00)	1550 (200~1680)	3.42	A	1.46 + 1.83 + 3.51	6.80 (1.50~7.20)	1680 (200~1860)	4.05	A
15 + 18 + 50	0.96 + 1.15 + 3.19	5.30 (1.50~6.00)	1550 (200~1680)	3.42	A	1.24 + 1.55 + 4.02	6.80 (1.50~7.20)	1680 (200~1860)	4.05	A
15 + 25 + 25	1.22 + 2.04 + 2.04	5.30 (1.50~6.00)	1550 (200~1680)	3.42	A	1.39 + 2.71 + 2.71	6.80 (1.50~7.20)	1680 (200~1860)	4.05	A
15 + 25 + 35	1.06 + 1.77 + 2.47	5.30 (1.50~6.00)	1550 (200~1680)	3.42	A	1.27 + 2.48 + 3.05	6.80 (1.50~7.20)	1680 (200~1860)	4.05	A
15 + 35 + 35	0.94 + 2.18 + 2.18	5.30 (1.50~6.00)	1550 (200~1680)	3.42	A	1.17 + 2.81 + 2.81	6.80 (1.50~7.20)	1680 (200~1860)	4.05	A
18 + 18 + 18	1.77 + 1.77 + 1.77	5.30 (1.50~6.00)	1550 (200~1680)	3.42	A	2.27 + 2.27 + 2.27	6.80 (1.50~7.20)	1680 (200~1860)	4.05	A
18 + 18 + 25	1.56 + 1.56 + 2.17	5.30 (1.50~6.40)	1550 (200~1680)	3.42	A	1.91 + 1.91 + 2.98	6.80 (1.50~7.20)	1680 (200~1860)	4.05	A
18 + 18 + 35	1.34 + 1.34 + 2.61	5.30 (1.50~6.60)	1550 (200~1680)	3.42	A	1.73 + 1.73 + 3.33	6.80 (1.50~7.20)	1680 (200~1860)	4.05	A
18 + 18 + 50	1.11 + 1.11 + 3.08	5.30 (1.50~6.60)	1550 (200~1680)	3.42	A	1.48 + 1.48 + 3.84	6.80 (1.50~7.20)	1680 (200~1860)	4.05	A
18 + 25 + 25	1.40 + 1.95 + 1.95	5.30 (1.50~6.60)	1550 (200~1680)	3.42	A	1.65 + 2.57 + 2.57	6.80 (1.50~7.20)	1680 (200~1860)	4.05	A
18 + 25 + 35	1.22 + 1.70 + 2.38	5.30 (1.50~6.60)	1550 (200~1680)	3.42	A	1.52 + 2.37 + 2.91	6.80 (1.50~7.20)	1680 (200~1860)	4.05	A
18 + 35 + 35	1.08 + 2.11 + 2.11	5.30 (1.50~6.60)	1550 (200~1680)	3.42	A	1.40 + 2.70 + 2.70	6.80 (1.50~7.20)	1680 (200~1860)	4.05	A
25 + 25 + 25	1.77 + 1.77 + 1.77	5.30 (1.50~6.60)	1550 (200~1680)	3.42	A	2.27 + 2.27 + 2.27	6.80 (1.50~7.20)	1680 (200~1860)	4.05	A
25 + 25 + 35	1.56 + 1.56 + 2.18	5.30 (1.50~6.60)	1550 (200~1680)	3.42	A	2.00 + 2.00 + 2.80	6.80 (1.50~7.20)	1680 (200~1860)	4.05	A

3 UNITS



POSSIBLE COMBINATIONS OF INDOOR UNITS	COOLING MODE					HEATING MODE				
	Unit power (kW)	Total power (kW)	Total Abs. power (W)	EER	Energy class	Unit power (kW)	Total power (kW)	Abs. power Total(W)	COP	Energy class
(15 + 15) + (15 + 15)	(1.50 + 1.50) + (1.50 + 1.50)	6.00 (1.50~7.80)	1840 (200~1980)	3.26	A	(2.00 + 2.00) + (2.00 + 2.00)	8.00 (1.50~9.40)	2120 (200~2760)	3.77	A
(15 + 15) + (15 + 18)	(1.50 + 1.50) + (1.50 + 1.80)	6.30 (1.50~7.80)	1940 (200~2350)	3.25	A	(2.00 + 2.00) + (2.00 + 2.50)	8.50 (1.50~9.90)	2310 (200~3250)	3.68	A
(15 + 18) + (15 + 18)	(1.50 + 1.80) + (1.50 + 1.80)	6.60 (1.50~7.80)	2040 (200~2350)	3.24	A	(2.00 + 2.50) + (2.00 + 2.50)	9.00 (1.50~10.40)	2500 (200~3740)	3.60	A
(15 + 15) + (15 + 25)	(1.50 + 1.50) + (1.50 + 2.50)	7.00 (1.50~8.40)	2100 (200~2600)	3.33	A	(2.00 + 2.00) + (2.00 + 3.90)	9.90 (1.50~11.20)	2680 (200~3390)	3.69	A
(15 + 25) + (15 + 25)	(1.50 + 2.50) + (1.50 + 2.50)	8.00 (1.50~9.00)	2360 (200~2600)	3.39	A	(2.00 + 3.90) + (2.00 + 3.90)	11.80 (1.50~13.00)	3240 (200~4020)	3.64	A
(15 + 15) + (15 + 35)	(1.50 + 1.50) + (1.50 + 3.50)	8.00 (1.50~9.80)	2400 (200~3260)	3.33	A	(2.00 + 2.00) + (2.00 + 4.80)	10.80 (1.50~11.90)	2880 (200~3390)	3.75	A
(15 + 35) + (15 + 35)	(1.20 + 3.50) + (1.50 + 3.50)	9.70 (1.50~11.80)	2960 (200~3260)	3.28	A	(2.00 + 4.80) + (2.00 + 4.80)	13.60 (1.50~14.40)	3640 (200~4020)	3.74	A
(15 + 15) + (15 + 50)	(1.50 + 1.50) + (1.22 + 4.08)	8.30 (1.50~9.80)	2470 (200~3640)	3.36	A	(2.00 + 2.00) + (1.60 + 5.20)	10.80 (1.50~11.90)	2880 (200~3390)	3.75	A
(15 + 50) + (15 + 50)	(1.22 + 4.08) + (1.22 + 4.08)	10.6 (1.50~11.80)	3100 (200~3640)	3.42	A	(1.60 + 5.20) + (1.60 + 5.20)	13.60 (1.50~14.40)	3640 (200~4020)	3.74	A
(18 + 18) + (18 + 18)	(1.80 + 1.80) + (1.80 + 1.80)	7.20 (1.50~8.00)	2160 (200~2600)	3.33	A	(2.50 + 2.50) + (2.50 + 2.50)	10.00 (1.50~10.40)	2580 (200~3100)	3.88	A
(18 + 18) + (18 + 25)	(1.80 + 1.80) + (1.80 + 2.50)	7.90 (1.50~8.60)	2360 (200~2900)	3.35	A	(2.50 + 2.50) + (2.50 + 3.90)	11.40 (1.50~11.50)	2990 (200~3470)	3.81	A
(18 + 25) + (18 + 25)	(1.80 + 2.50) + (1.80 + 2.50)	8.60 (1.50~9.20)	2560 (200~2900)	3.36	A	(2.50 + 3.90) + (2.50 + 3.90)	12.80 (1.50~12.60)	3400 (200~3840)	3.76	A
(18 + 18) + (18 + 35)	(1.80 + 1.80) + (1.80 + 3.50)	8.90 (1.50~9.60)	2630 (200~3480)	3.38	A	(2.50 + 2.50) + (2.33 + 4.47)	11.80 (1.50~12.40)	3140 (200~3560)	3.76	A
(18 + 25) + (18 + 35)	(1.80 + 2.50) + (1.80 + 3.50)	9.60 (1.50~10.20)	2830 (200~3480)	3.39	A	(2.50 + 3.90) + (2.33 + 4.47)	13.20 (1.50~13.50)	3550 (200~3930)	3.72	A
(18 + 18) + (18 + 50)	(1.80 + 1.80) + (1.40 + 3.90)	8.90 (1.50~9.90)	2630 (200~3640)	3.38	A	(2.50 + 2.50) + (1.80 + 5.00)	11.80 (1.50~12.40)	3110 (200~3560)	3.79	A
(18 + 25) + (18 + 50)	(1.80 + 2.50) + (1.40 + 3.90)	9.60 (1.50~10.50)	2830 (200~3640)	3.39	A	(2.50 + 3.90) + (1.80 + 5.00)	13.20 (1.50~13.50)	3520 (200~3930)	3.75	A
(18 + 35) + (18 + 35)	(1.80 + 3.50) + (1.80 + 3.50)	10.60 (1.50~11.20)	3100 (200~3480)	3.42	A	(2.33 + 4.47) + (2.33 + 4.47)	13.60 (1.50~14.40)	3700 (200~4020)	3.68	A
(18 + 35) + (18 + 50)	(1.80 + 3.50) + (1.40 + 3.90)	10.60 (1.50~11.50)	3100 (200~3640)	3.42	A	(2.33 + 4.47) + (1.80 + 5.00)	13.60 (1.50~14.40)	3670 (200~4020)	3.71	A
(18 + 50) + (18 + 50)	(1.40 + 3.90) + (1.40 + 3.90)	10.60 (1.50~11.80)	3100 (200~3640)	3.42	A	(1.80 + 5.00) + (1.80 + 5.00)	13.60 (1.50~14.40)	3640 (200~4020)	3.74	A
(18 + 25) + (25 + 25)	(1.80 + 2.50) + (2.50 + 2.50)	9.30 (1.50~10.20)	2750 (200~3480)	3.38	A	(2.50 + 3.90) + (3.40 + 3.40)	13.20 (1.50~13.50)	3520 (200~3930)	3.75	A
(18 + 50) + (25 + 25)	(1.40 + 3.90) + (2.50 + 2.50)	10.30 (1.50~11.50)	3020 (200~3480)	3.41	A	(1.80 + 5.00) + (3.40 + 3.40)	13.60 (1.50~14.40)	3640 (200~4020)	3.74	A
(18 + 35) + (25 + 25)	(1.80 + 3.50) + (2.50 + 2.50)	10.30 (1.50~11.20)	3020 (200~3480)	3.41	A	(2.33 + 4.47) + (3.40 + 3.40)	13.60 (1.50~14.40)	3670 (200~4020)	3.71	A
(18 + 35) + (25 + 35)	(1.80 + 3.50) + (2.21 + 3.09)	10.60 (1.50~11.30)	3100 (200~3560)	3.42	A	(2.33 + 4.47) + (2.83 + 3.97)	13.60 (1.50~14.40)	3670 (200~4020)	3.71	A
(18 + 50) + (25 + 35)	(1.40 + 3.90) + (2.21 + 3.09)	10.60 (1.50~11.60)	3100 (200~3560)	3.42	A	(1.80 + 5.00) + (2.83 + 3.97)	13.60 (1.50~14.40)	3640 (200~4020)	3.74	A
(18 + 50) + (25 + 50)	(1.40 + 3.90) + (1.77 + 3.53)	10.60 (1.50~11.80)	3100 (200~3640)	3.42	A	(1.80 + 5.00) + (2.55 + 4.25)	13.60 (1.50~14.40)	3610 (200~4020)	3.77	A
(18 + 35) + (35 + 35)	(1.80 + 3.50) + (2.65 + 2.65)	10.60 (1.50~11.50)	3100 (200~3640)	3.42	A	(2.33 + 4.47) + (3.40 + 3.40)	13.60 (1.50~14.40)	3640 (200~4020)	3.74	A
(18 + 50) + (35 + 35)	(1.40 + 3.90) + (2.65 + 2.65)	10.60 (1.50~11.80)	3100 (200~3640)	3.42	A	(1.80 + 5.00) + (3.40 + 3.40)	13.60 (1.50~14.40)	3610 (200~4020)	3.77	A
(18 + 50) + (35 + 50)	(1.40 + 3.90) + (2.18 + 3.12)	10.60 (1.50~12.50)	3100 (200~3860)	3.42	A	(1.80 + 5.00) + (2.89 + 3.91)	13.60 (1.50~14.40)	3610 (200~4020)	3.77	A
(25 + 25) + (25 + 25)	(2.50 + 2.50) + (2.50 + 2.50)	10.00 (1.50~11.20)	2940 (200~3480)	3.40	A	(3.40 + 3.40) + (3.40 + 3.40)	13.60 (1.50~14.40)	3640 (200~4020)	3.74	A
(25 + 25) + (25 + 35)	(2.50 + 2.50) + (2.21 + 3.09)	10.30 (1.50~11.30)	3020 (200~3580)	3.41	A	(3.40 + 3.40) + (2.83 + 3.97)	13.60 (1.50~14.40)	3640 (200~4020)	3.74	A
(25 + 25) + (25 + 50)	(2.50 + 2.50) + (1.77 + 3.53)	10.30 (1.50~11.50)	3020 (200~3660)	3.41	A	(3.40 + 3.40) + (2.55 + 4.25)	13.60 (1.50~14.40)	3610 (200~4020)	3.77	A
(25 + 35) + (25 + 35)	(2.21 + 3.09) + (2.21 + 3.09)	10.60 (1.50~11.40)	3100 (200~3560)	3.42	A	(2.83 + 3.97) + (2.83 + 3.97)	13.60 (1.50~14.40)	3640 (200~4020)	3.74	A
(25 + 50) + (25 + 35)	(1.77 + 3.53) + (2.21 + 3.09)	10.60 (1.50~11.60)	3100 (200~3560)	3.42	A	(2.55 + 4.25) + (2.83 + 3.97)	13.60 (1.50~14.40)	3610 (200~4020)	3.77	A
(25 + 50) + (25 + 50)	(1.77 + 3.53) + (1.77 + 3.53)	10.60 (1.50~11.80)	3100 (200~3660)	3.42	A	(2.55 + 4.25) + (2.55 + 4.25)	13.60 (1.50~14.40)	3580 (200~4020)	3.80	A
(25 + 35) + (35 + 35)	(2.21 + 3.09) + (2.65 + 2.65)	10.60 (1.50~11.60)	3100 (200~3660)	3.42	A	(2.83 + 3.97) + (3.40 + 3.40)	13.60 (1.50~14.40)	3610 (200~4020)	3.77	A
(25 + 50) + (35 + 35)	(1.77 + 3.53) + (2.65 + 2.65)	10.60 (1.50~11.80)	3100 (200~3660)	3.42	A	(2.55 + 4.25) + (3.40 + 3.40)	13.60 (1.50~14.40)	3580 (200~4020)	3.80	A
(35 + 35) + (35 + 35)	(2.65 + 2.65) + (2.65 + 2.65)	10.60 (1.50~11.80)	3100 (200~3660)	3.42	A	(3.40 + 3.40) + (3.40 + 3.40)	13.60 (1.50~14.40)	3580 (200~4020)	3.80	A
(35 + 35) + (35 + 50)	(2.65 + 2.65) + (2.18 + 3.12)	10.60 (1.50~12.50)	3100 (200~3880)	3.42	A	(3.40 + 3.40) + (2.89 + 3.91)	13.60 (1.50~14.40)	3580 (200~4020)	3.80	A
(35 + 50) + (35 + 50)	(2.18 + 3.12) + (2.18 + 3.12)	10.60 (1.50~13.20)	3100 (200~3880)	3.42	A	(2.89 + 3.91) + (2.89 + 3.91)	13.60 (1.50~14.40)	3580 (200~4020)	3.80	A

POSSIBLE COMBINATIONS OF INDOOR UNITS	COOLING MODE					HEATING MODE				
	Unit power (kW)	Total power (kW)	Total Abs. power (W)	EER	Energy class	Unit power (kW)	Total power (kW)	Total Abs. power (W)	COP	Energy class
(15 + 15) + (15 + 15 + 15)	(1.50 + 1.50) + (1.50 + 1.50 + 1.50)	7.50 (1.50-8.90)	2240 (200-3360)	3.35	A	(2.00 + 2.00) + (2.00 + 2.00 + 2.00)	10.00 (1.50-10.90)	2640 (200-2930)	3.79	A
(15 + 15) + (15 + 15 + 18)	(1.50 + 1.50) + (1.50 + 1.50 + 1.80)	7.80 (1.50-9.90)	2340 (200-3360)	3.33	A	(2.00 + 2.00) + (2.00 + 2.00 + 2.50)	10.50 (1.50-11.30)	2680 (200-3140)	3.92	A
(15 + 15) + (15 + 15 + 25)	(1.50 + 1.50) + (1.45 + 1.45 + 2.41)	8.30 (1.50-9.90)	2470 (200-3340)	3.36	A	(2.00 + 2.00) + (1.72 + 1.72 + 3.36)	10.80 (1.50-11.90)	2740 (200-3240)	3.94	A
(15 + 15) + (15 + 15 + 35)	(1.50 + 1.50) + (1.22 + 1.22 + 2.85)	8.30 (1.50-9.90)	2470 (200-3360)	3.36	A	(2.00 + 2.00) + (1.55 + 1.55 + 3.71)	10.80 (1.50-11.90)	2740 (200-3240)	3.94	A
(15 + 15) + (15 + 15 + 50)	(1.50 + 1.50) + (0.99 + 0.99 + 3.31)	8.30 (1.50-9.90)	2470 (200-3880)	3.36	A	(2.00 + 2.00) + (1.30 + 1.30 + 4.21)	10.80 (1.50-11.90)	2740 (200-3240)	3.94	A
(15 + 15) + (15 + 18 + 18)	(1.50 + 1.50) + (1.50 + 1.80 + 1.80)	8.10 (1.50-9.90)	2420 (200-3340)	3.35	A	(2.00 + 2.00) + (1.94 + 2.43 + 2.43)	10.80 (1.50-11.90)	2740 (200-3240)	3.94	A
(15 + 15) + (15 + 18 + 25)	(1.50 + 1.50) + (1.37 + 1.64 + 2.28)	8.30 (1.50-9.90)	2470 (200-3880)	3.36	A	(2.00 + 2.00) + (1.62 + 2.02 + 3.16)	10.80 (1.50-11.90)	2740 (200-3240)	3.94	A
(15 + 15) + (15 + 18 + 35)	(1.50 + 1.50) + (1.17 + 1.40 + 2.73)	8.30 (1.50-9.90)	2470 (200-3880)	3.36	A	(2.00 + 2.00) + (1.46 + 1.83 + 3.51)	10.80 (1.50-11.90)	2740 (200-3240)	3.94	A
(15 + 15) + (15 + 18 + 50)	(1.50 + 1.50) + (0.96 + 1.15 + 3.19)	8.30 (1.50-9.90)	2470 (200-3880)	3.36	A	(2.00 + 2.00) + (1.24 + 1.55 + 4.02)	10.80 (1.50-11.90)	2740 (200-3240)	3.94	A
(15 + 15) + (15 + 25 + 25)	(1.50 + 1.50) + (1.22 + 2.04 + 2.04)	8.30 (1.50-9.90)	2470 (200-3880)	3.36	A	(2.00 + 2.00) + (1.39 + 2.71 + 2.71)	10.80 (1.50-11.90)	2740 (200-3240)	3.94	A
(15 + 15) + (15 + 25 + 35)	(1.50 + 1.50) + (1.06 + 1.77 + 2.47)	8.30 (1.50-9.90)	2470 (200-3860)	3.36	A	(2.00 + 2.00) + (1.27 + 2.48 + 3.05)	10.80 (1.50-11.90)	2740 (200-3240)	3.94	A
(15 + 15) + (15 + 35 + 35)	(1.50 + 1.50) + (0.94 + 2.18 + 2.18)	8.30 (1.50-9.90)	2470 (200-3880)	3.36	A	(2.00 + 2.00) + (1.17 + 2.81 + 2.81)	10.80 (1.50-11.90)	2740 (200-3240)	3.94	A
(15 + 15) + (18 + 18 + 18)	(1.50 + 1.50) + (1.77 + 1.77 + 1.77)	8.30 (1.50-9.90)	2470 (200-3880)	3.36	A	(2.00 + 2.00) + (2.27 + 2.27 + 2.27)	10.80 (1.50-11.90)	2740 (200-3240)	3.94	A
(15 + 15) + (18 + 18 + 25)	(1.50 + 1.50) + (1.56 + 1.56 + 2.17)	8.30 (1.50-10.30)	2470 (200-3860)	3.36	A	(2.00 + 2.00) + (1.91 + 1.91 + 2.98)	10.80 (1.50-11.90)	2740 (200-3240)	3.94	A
(15 + 15) + (18 + 18 + 35)	(1.50 + 1.50) + (1.34 + 1.34 + 2.61)	8.30 (1.50-10.50)	2470 (200-3880)	3.36	A	(2.00 + 2.00) + (1.73 + 1.73 + 3.33)	10.80 (1.50-11.90)	2740 (200-3240)	3.94	A
(15 + 15) + (18 + 18 + 50)	(1.50 + 1.50) + (1.11 + 1.11 + 3.08)	8.30 (1.50-10.50)	2470 (200-3880)	3.36	A	(2.00 + 2.00) + (1.48 + 1.48 + 3.84)	10.80 (1.50-11.90)	2740 (200-3240)	3.94	A
(15 + 15) + (18 + 25 + 25)	(1.50 + 1.50) + (1.40 + 1.95 + 1.95)	8.30 (1.50-10.50)	2470 (200-3880)	3.36	A	(2.00 + 2.00) + (1.65 + 2.57 + 2.57)	10.80 (1.50-11.90)	2740 (200-3240)	3.94	A
(15 + 15) + (18 + 25 + 35)	(1.50 + 1.50) + (1.22 + 1.70 + 2.38)	8.30 (1.50-10.50)	2470 (200-3880)	3.36	A	(2.00 + 2.00) + (1.52 + 2.37 + 2.91)	10.80 (1.50-11.90)	2740 (200-3240)	3.94	A
(15 + 15) + (18 + 35 + 35)	(1.50 + 1.50) + (1.08 + 2.11 + 2.11)	8.30 (1.50-10.50)	2470 (200-3880)	3.36	A	(2.00 + 2.00) + (1.40 + 2.70 + 2.70)	10.80 (1.50-11.90)	2740 (200-3240)	3.94	A
(15 + 15) + (25 + 25 + 25)	(1.50 + 1.50) + (1.77 + 1.77 + 1.77)	8.30 (1.50-10.50)	2470 (200-3880)	3.36	A	(2.00 + 2.00) + (2.27 + 2.27 + 2.27)	10.80 (1.50-11.90)	2740 (200-3240)	3.94	A
(15 + 15) + (25 + 25 + 35)	(1.50 + 1.50) + (1.56 + 1.56 + 2.18)	8.30 (1.50-10.50)	2470 (200-3880)	3.36	A	(2.00 + 2.00) + (2.00 + 2.00 + 2.80)	10.80 (1.50-11.90)	2740 (200-3240)	3.94	A
(15 + 18) + (15 + 15 + 15)	(1.50 + 1.80) + (1.50 + 1.50 + 1.50)	7.80 (1.50-8.90)	2340 (200-3360)	3.33	A	(2.00 + 2.50) + (2.00 + 2.00 + 2.00)	10.50 (1.50-11.40)	2830 (200-3420)	3.71	A
(15 + 18) + (15 + 15 + 18)	(1.50 + 1.80) + (1.50 + 1.50 + 1.80)	8.10 (1.50-9.90)	2440 (200-3360)	3.32	A	(2.00 + 2.50) + (2.00 + 2.00 + 2.50)	11.00 (1.50-11.80)	2870 (200-3630)	3.83	A
(15 + 18) + (15 + 15 + 25)	(1.50 + 1.80) + (1.45 + 1.45 + 2.41)	8.60 (1.50-9.90)	2570 (200-3340)	3.35	A	(2.00 + 2.50) + (1.72 + 1.72 + 3.36)	11.30 (1.50-12.40)	2930 (200-3730)	3.86	A
(15 + 18) + (15 + 15 + 35)	(1.50 + 1.80) + (1.22 + 1.22 + 2.85)	8.60 (1.50-9.90)	2570 (200-3360)	3.35	A	(2.00 + 2.50) + (1.55 + 1.55 + 3.71)	11.30 (1.50-12.40)	2930 (200-3730)	3.86	A
(15 + 18) + (15 + 15 + 50)	(1.50 + 1.80) + (0.99 + 0.99 + 3.31)	8.60 (1.50-9.90)	2570 (200-3880)	3.35	A	(2.00 + 2.50) + (1.30 + 1.30 + 4.21)	11.30 (1.50-12.40)	2930 (200-3730)	3.86	A
(15 + 18) + (15 + 18 + 18)	(1.50 + 1.80) + (1.50 + 1.80 + 1.80)	8.40 (1.50-9.90)	2520 (200-3340)	3.33	A	(2.00 + 2.50) + (1.94 + 2.43 + 2.43)	11.30 (1.50-12.40)	2930 (200-3730)	3.86	A
(15 + 18) + (15 + 18 + 25)	(1.50 + 1.80) + (1.37 + 1.64 + 2.28)	8.60 (1.50-9.90)	2570 (200-3880)	3.35	A	(2.00 + 2.50) + (1.62 + 2.02 + 3.16)	11.30 (1.50-12.40)	2930 (200-3730)	3.86	A
(15 + 18) + (15 + 18 + 35)	(1.50 + 1.80) + (1.17 + 1.40 + 2.73)	8.60 (1.50-9.90)	2570 (200-3880)	3.35	A	(2.00 + 2.50) + (1.46 + 1.83 + 3.51)	11.30 (1.50-12.40)	2930 (200-3730)	3.86	A
(15 + 18) + (15 + 18 + 50)	(1.50 + 1.80) + (0.96 + 1.15 + 3.19)	8.60 (1.50-9.90)	2570 (200-3880)	3.35	A	(2.00 + 2.50) + (1.24 + 1.55 + 4.02)	11.30 (1.50-12.40)	2930 (200-3730)	3.86	A
(15 + 18) + (15 + 25 + 25)	(1.50 + 1.80) + (1.22 + 2.04 + 2.04)	8.60 (1.50-9.90)	2570 (200-3880)	3.35	A	(2.00 + 2.50) + (1.39 + 2.71 + 2.71)	11.30 (1.50-12.40)	2930 (200-3730)	3.86	A
(15 + 18) + (15 + 25 + 35)	(1.50 + 1.80) + (1.06 + 1.77 + 2.47)	8.60 (1.50-9.90)	2570 (200-3860)	3.35	A	(2.00 + 2.50) + (1.27 + 2.48 + 3.05)	11.30 (1.50-12.40)	2930 (200-3730)	3.86	A
(15 + 18) + (15 + 35 + 35)	(1.50 + 1.80) + (0.94 + 2.18 + 2.18)	8.60 (1.50-9.90)	2570 (200-3880)	3.35	A	(2.00 + 2.50) + (1.17 + 2.81 + 2.81)	11.30 (1.50-12.40)	2930 (200-3730)	3.86	A
(15 + 18) + (18 + 18 + 18)	(1.50 + 1.80) + (1.77 + 1.77 + 1.77)	8.60 (1.50-9.90)	2570 (200-3880)	3.35	A	(2.00 + 2.50) + (2.27 + 2.27 + 2.27)	11.30 (1.50-12.40)	2930 (200-3730)	3.86	A
(15 + 18) + (18 + 18 + 25)	(1.50 + 1.80) + (1.56 + 1.56 + 2.17)	8.60 (1.50-10.30)	2570 (200-3860)	3.35	A	(2.00 + 2.50) + (1.91 + 1.91 + 2.98)	11.30 (1.50-12.40)	2930 (200-3730)	3.86	A
(15 + 18) + (18 + 18 + 35)	(1.50 + 1.80) + (1.34 + 1.34 + 2.61)	8.60 (1.50-10.50)	2570 (200-3880)	3.35	A	(2.00 + 2.50) + (1.73 + 1.73 + 3.33)	11.30 (1.50-12.40)	2930 (200-3730)	3.86	A
(15 + 18) + (18 + 18 + 50)	(1.50 + 1.80) + (1.11 + 1.11 + 3.08)	8.60 (1.50-10.50)	2570 (200-3880)	3.35	A	(2.00 + 2.50) + (1.48 + 1.48 + 3.84)	11.30 (1.50-12.40)	2930 (200-3730)	3.86	A
(15 + 18) + (18 + 25 + 25)	(1.50 + 1.80) + (1.40 + 1.95 + 1.95)	8.60 (1.50-10.50)	2570 (200-3880)	3.35	A	(2.00 + 2.50) + (1.65 + 2.57 + 2.57)	11.30 (1.50-12.40)	2930 (200-3730)	3.86	A

POSSIBLE COMBINATIONS OF INDOOR UNITS	COOLING MODE					HEATING MODE				
	Unit power (kW)	Total power (kW)	Total Abs. power (W)	EER	Energy class	Unit power (kW)	Total power (kW)	Total Abs. power (W)	COP	Energy class
(15 + 18) + (18 + 25 + 35)	(1.50 + 1.80) + (1.22 + 1.70 + 2.38)	8.60 (1.50-10.50)	2570 (200-3880)	3.35	A	(2.00 + 2.50) + (1.52 + 2.37 + 2.91)	11.30 (1.50-12.40)	2930 (200-3730)	3.86	A
(15 + 18) + (18 + 35 + 35)	(1.50 + 1.80) + (1.08 + 2.11 + 2.11)	8.60 (1.50-10.50)	2570 (200-3880)	3.35	A	(2.00 + 2.50) + (1.40 + 2.70 + 2.70)	11.30 (1.50-12.40)	2930 (200-3730)	3.86	A
(15 + 18) + (25 + 25 + 25)	(1.50 + 1.80) + (1.77 + 1.77 + 1.77)	8.60 (1.50-10.50)	2570 (200-3880)	3.35	A	(2.00 + 2.50) + (2.27 + 2.27 + 2.27)	11.30 (1.50-12.40)	2930 (200-3730)	3.86	A
(15 + 18) + (25 + 25 + 35)	(1.50 + 1.80) + (1.56 + 1.56 + 2.18)	8.60 (1.50-10.50)	2570 (200-3880)	3.35	A	(2.00 + 2.50) + (2.00 + 2.00 + 2.80)	11.30 (1.50-12.40)	2930 (200-3730)	3.86	A
(15 + 25) + (15 + 15 + 15)	(1.50 + 2.50) + (1.50 + 1.50 + 1.50)	8.50 (1.50-9.50)	2500 (200-3360)	3.40	A	(2.00 + 3.90) + (2.00 + 2.00 + 2.00)	11.90 (1.50-12.70)	3200 (200-3560)	3.72	A
(15 + 25) + (15 + 15 + 18)	(1.50 + 2.50) + (1.50 + 1.50 + 1.80)	8.80 (1.50-10.50)	2600 (200-3360)	3.38	A	(2.00 + 3.90) + (2.00 + 2.00 + 2.50)	12.40 (1.50-13.10)	3240 (200-3770)	3.83	A
(15 + 25) + (15 + 15 + 25)	(1.50 + 2.50) + (1.45 + 1.45 + 2.41)	9.30 (1.50-10.50)	2730 (200-3340)	3.41	A	(2.00 + 3.90) + (1.72 + 1.72 + 3.36)	12.70 (1.50-13.70)	3300 (200-3870)	3.85	A
(15 + 25) + (15 + 15 + 35)	(1.50 + 2.50) + (1.22 + 1.22 + 2.85)	9.30 (1.50-10.50)	2730 (200-3360)	3.41	A	(2.00 + 3.90) + (1.55 + 1.55 + 3.71)	12.70 (1.50-13.70)	3300 (200-3870)	3.85	A
(15 + 25) + (15 + 15 + 50)	(1.50 + 2.50) + (0.99 + 0.99 + 3.31)	9.30 (1.50-10.50)	2730 (200-3880)	3.41	A	(2.00 + 3.90) + (1.30 + 1.30 + 4.21)	12.70 (1.50-13.70)	3300 (200-3870)	3.85	A
(15 + 25) + (15 + 18 + 18)	(1.50 + 2.50) + (1.50 + 1.80 + 1.80)	9.10 (1.50-10.50)	2680 (200-3340)	3.40	A	(2.00 + 3.90) + (1.94 + 2.43 + 2.43)	12.70 (1.50-13.70)	3300 (200-3870)	3.85	A
(15 + 25) + (15 + 18 + 25)	(1.50 + 2.50) + (1.37 + 1.64 + 2.28)	9.30 (1.50-10.50)	2730 (200-3880)	3.41	A	(2.00 + 3.90) + (1.62 + 2.02 + 3.16)	12.70 (1.50-13.70)	3300 (200-3870)	3.85	A
(15 + 25) + (15 + 18 + 35)	(1.50 + 2.50) + (1.17 + 1.40 + 2.73)	9.30 (1.50-10.50)	2730 (200-3880)	3.41	A	(2.00 + 3.90) + (1.46 + 1.83 + 3.51)	12.70 (1.50-13.70)	3300 (200-3870)	3.85	A
(15 + 25) + (15 + 18 + 50)	(1.50 + 2.50) + (0.96 + 1.15 + 3.19)	9.30 (1.50-10.50)	2730 (200-3880)	3.41	A	(2.00 + 3.90) + (1.24 + 1.55 + 4.02)	12.70 (1.50-13.70)	3300 (200-3870)	3.85	A
(15 + 25) + (15 + 25 + 25)	(1.50 + 2.50) + (1.22 + 2.04 + 2.04)	9.30 (1.50-10.50)	2730 (200-3880)	3.41	A	(2.00 + 3.90) + (1.39 + 2.71 + 2.71)	12.70 (1.50-13.70)	3300 (200-3870)	3.85	A
(15 + 25) + (15 + 25 + 35)	(1.50 + 2.50) + (1.06 + 1.77 + 2.47)	9.30 (1.50-10.50)	2730 (200-3860)	3.41	A	(2.00 + 3.90) + (1.27 + 2.48 + 3.05)	12.70 (1.50-13.70)	3300 (200-3870)	3.85	A
(15 + 25) + (15 + 35 + 35)	(1.50 + 2.50) + (0.94 + 2.18 + 2.18)	9.30 (1.50-10.50)	2730 (200-3880)	3.41	A	(2.00 + 3.90) + (1.17 + 2.81 + 2.81)	12.70 (1.50-13.70)	3300 (200-3870)	3.85	A
(15 + 25) + (18 + 18 + 18)	(1.50 + 2.50) + (1.77 + 1.77 + 1.77)	9.30 (1.50-10.50)	2730 (200-3880)	3.41	A	(2.00 + 3.90) + (2.27 + 2.27 + 2.27)	12.70 (1.50-13.70)	3300 (200-3870)	3.85	A
(15 + 25) + (18 + 18 + 25)	(1.50 + 2.50) + (1.56 + 1.56 + 2.17)	9.30 (1.50-10.90)	2730 (200-3860)	3.41	A	(2.00 + 3.90) + (1.91 + 1.91 + 2.98)	12.70 (1.50-13.70)	3300 (200-3870)	3.85	A
(15 + 25) + (18 + 18 + 35)	(1.50 + 2.50) + (1.34 + 1.34 + 2.61)	9.30 (1.50-11.10)	2730 (200-3880)	3.41	A	(2.00 + 3.90) + (1.73 + 1.73 + 3.33)	12.70 (1.50-13.70)	3300 (200-3870)	3.85	A
(15 + 25) + (18 + 18 + 50)	(1.50 + 2.50) + (1.11 + 1.11 + 3.08)	9.30 (1.50-11.10)	2730 (200-3880)	3.41	A	(2.00 + 3.90) + (1.48 + 1.48 + 3.84)	12.70 (1.50-13.70)	3300 (200-3870)	3.85	A
(15 + 25) + (18 + 25 + 25)	(1.50 + 2.50) + (1.40 + 1.95 + 1.95)	9.30 (1.50-11.10)	2730 (200-3880)	3.41	A	(2.00 + 3.90) + (1.65 + 2.57 + 2.57)	12.70 (1.50-13.70)	3300 (200-3870)	3.85	A
(15 + 25) + (18 + 25 + 35)	(1.50 + 2.50) + (1.22 + 1.70 + 2.38)	9.30 (1.50-11.10)	2730 (200-3880)	3.41	A	(2.00 + 3.90) + (1.52 + 2.37 + 2.91)	12.70 (1.50-13.70)	3300 (200-3870)	3.85	A
(15 + 25) + (18 + 35 + 35)	(1.50 + 2.50) + (1.08 + 2.11 + 2.11)	9.30 (1.50-11.10)	2730 (200-3880)	3.41	A	(2.00 + 3.90) + (1.40 + 2.70 + 2.70)	12.70 (1.50-13.70)	3300 (200-3870)	3.85	A
(15 + 25) + (25 + 25 + 25)	(1.50 + 2.50) + (1.77 + 1.77 + 1.77)	9.30 (1.50-11.10)	2730 (200-3880)	3.41	A	(2.00 + 3.90) + (2.27 + 2.27 + 2.27)	12.70 (1.50-13.70)	3300 (200-3870)	3.85	A
(15 + 25) + (25 + 25 + 35)	(1.50 + 2.50) + (1.56 + 1.56 + 2.18)	9.30 (1.50-11.10)	2730 (200-3880)	3.41	A	(2.00 + 3.90) + (2.00 + 2.00 + 2.80)	12.70 (1.50-13.70)	3300 (200-3870)	3.85	A
(15 + 35) + (15 + 15 + 15)	(1.50 + 3.50) + (1.50 + 1.50 + 1.50)	9.50 (1.50-10.90)	2800 (200-3360)	3.39	A	(2.00 + 4.80) + (2.00 + 2.00 + 2.00)	12.80 (1.50-13.40)	3400 (200-3560)	3.76	A
(15 + 35) + (15 + 15 + 18)	(1.50 + 3.50) + (1.50 + 1.50 + 1.80)	9.80 (1.50-11.90)	2900 (200-3360)	3.38	A	(2.00 + 4.80) + (2.00 + 2.00 + 2.50)	13.30 (1.50-13.80)	3440 (200-3770)	3.87	A
(15 + 35) + (15 + 15 + 25)	(1.50 + 3.50) + (1.45 + 1.45 + 2.41)	10.30 (1.50-11.90)	3030 (200-3340)	3.40	A	(2.00 + 4.80) + (1.72 + 1.72 + 3.36)	13.60 (1.50-14.40)	3500 (200-3870)	3.89	A
(15 + 35) + (15 + 15 + 35)	(1.50 + 3.50) + (1.22 + 1.22 + 2.85)	10.30 (1.50-11.90)	3030 (200-3360)	3.40	A	(2.00 + 4.80) + (1.55 + 1.55 + 3.71)	13.60 (1.50-14.40)	3500 (200-3870)	3.89	A
(15 + 35) + (15 + 15 + 50)	(1.50 + 3.50) + (0.99 + 0.99 + 3.31)	10.30 (1.50-11.90)	3030 (200-3880)	3.40	A	(2.00 + 4.80) + (1.30 + 1.30 + 4.21)	13.60 (1.50-14.40)	3500 (200-3870)	3.89	A
(15 + 35) + (15 + 18 + 18)	(1.50 + 3.50) + (1.50 + 1.80 + 1.80)	10.10 (1.50-11.90)	2980 (200-3340)	3.39	A	(2.00 + 4.80) + (1.94 + 2.43 + 2.43)	13.60 (1.50-14.40)	3500 (200-3870)	3.89	A
(15 + 35) + (15 + 18 + 25)	(1.50 + 3.50) + (1.37 + 1.64 + 2.28)	10.30 (1.50-11.90)	3030 (200-3880)	3.40	A	(2.00 + 4.80) + (1.62 + 2.02 + 3.16)	13.60 (1.50-14.40)	3500 (200-3870)	3.89	A
(15 + 35) + (15 + 18 + 35)	(1.50 + 3.50) + (1.17 + 1.40 + 2.73)	10.30 (1.50-11.90)	3030 (200-3880)	3.40	A	(2.00 + 4.80) + (1.46 + 1.83 + 3.51)	13.60 (1.50-14.40)	3500 (200-3870)	3.89	A
(15 + 35) + (15 + 18 + 50)	(1.50 + 3.50) + (0.96 + 1.15 + 3.19)	10.30 (1.50-11.90)	3030 (200-3880)	3.40	A	(2.00 + 4.80) + (1.24 + 1.55 + 4.02)	13.60 (1.50-14.40)	3500 (200-3870)	3.89	A
(15 + 35) + (15 + 25 + 25)	(1.50 + 3.50) + (1.22 + 2.04 + 2.04)	10.30 (1.50-11.90)	3030 (200-3880)	3.40	A	(2.00 + 4.80) + (1.39 + 2.71 + 2.71)	13.60 (1.50-14.40)	3500 (200-3870)	3.89	A
(15 + 35) + (15 + 25 + 35)	(1.50 + 3.50) + (1.06 + 1.77 + 2.47)	10.30 (1.50-11.90)	3030 (200-3860)	3.40	A	(2.00 + 4.80) + (1.27 + 2.48 + 3.05)	13.60 (1.50-14.40)	3500 (200-3870)	3.89	A
(15 + 35) + (15 + 35 + 35)	(1.50 + 3.50) + (0.94 + 2.18 + 2.18)	10.30 (1.50-11.90)	3030 (200-3880)	3.40	A	(2.00 + 4.80) + (1.17 + 2.81 + 2.81)	13.60 (1.50-14.40)	3500 (200-3870)	3.89	A
(15 + 35) + (18 + 18 + 18)	(1.50 + 3.50) + (1.77 + 1.77 + 1.77)	10.30 (1.50-11.90)	3030 (200-3880)	3.40	A	(2.00 + 4.80) + (2.27 + 2.27 + 2.27)	13.60 (1.50-14.40)	3500 (200-3870)	3.89	A
(15 + 35) + (18 + 18 + 25)	(1.50 + 3.50) + (1.56 + 1.56 + 2.17)	10.30 (1.50-12.30)	3030 (200-3860)	3.40	A	(2.00 + 4.80) + (1.91 + 1.91 + 2.98)	13.60 (1.50-14.40)	3500 (200-3870)	3.89	A



POSSIBLE COMBINATIONS OF INDOOR UNITS	COOLING MODE					HEATING MODE				
	Unit power (kW)	Total power (kW)	Total Abs. power (W)	EER	Energy class	Unit power (kW)	Total power (kW)	Total Abs. power (W)	COP	Energy class
(15 + 35) + (18 + 18 + 35)	(1.50 + 3.50) + (1.34 + 1.34 + 2.61)	10.30 (1.50-12.50)	3030 (200-3880)	3.40	A	(2.00 + 4.80) + (1.73 + 1.73 + 3.33)	13.60 (1.50-14.40)	3500 (200-3870)	3.89	A
(15 + 35) + (18 + 18 + 50)	(1.50 + 3.50) + (1.11 + 1.11 + 3.08)	10.30 (1.50-12.50)	3030 (200-3880)	3.40	A	(2.00 + 4.80) + (1.48 + 1.48 + 3.84)	13.60 (1.50-14.40)	3500 (200-3870)	3.89	A
(15 + 35) + (18 + 25 + 25)	(1.50 + 3.50) + (1.40 + 1.95 + 1.95)	10.30 (1.50-12.50)	3030 (200-3880)	3.40	A	(2.00 + 4.80) + (1.65 + 2.57 + 2.57)	13.60 (1.50-14.40)	3500 (200-3870)	3.89	A
(15 + 35) + (18 + 25 + 35)	(1.50 + 3.50) + (1.22 + 1.70 + 2.38)	10.30 (1.50-12.50)	3030 (200-3880)	3.40	A	(2.00 + 4.80) + (1.52 + 2.37 + 2.91)	13.60 (1.50-14.40)	3500 (200-3870)	3.89	A
(15 + 35) + (18 + 35 + 35)	(1.50 + 3.50) + (1.08 + 2.11 + 2.11)	10.30 (1.50-12.50)	3030 (200-3880)	3.40	A	(2.00 + 4.80) + (1.40 + 2.70 + 2.70)	13.60 (1.50-14.40)	3500 (200-3870)	3.89	A
(15 + 35) + (25 + 25 + 25)	(1.50 + 3.50) + (1.77 + 1.77 + 1.77)	10.30 (1.50-12.50)	3030 (200-3880)	3.40	A	(2.00 + 4.80) + (2.27 + 2.27 + 2.27)	13.60 (1.50-14.40)	3500 (200-3870)	3.89	A
(15 + 35) + (25 + 25 + 35)	(1.50 + 3.50) + (1.56 + 1.56 + 2.18)	10.30 (1.50-12.50)	3030 (200-3880)	3.40	A	(2.00 + 4.80) + (2.00 + 2.00 + 2.80)	13.60 (1.50-14.40)	3500 (200-3870)	3.89	A
(15 + 50) + (15 + 15 + 15)	(1.22 + 4.08) + (1.50 + 1.50 + 1.50)	9.80 (1.50-10.90)	2870 (200-3360)	3.41	A	(1.60 + 5.20) + (2.00 + 2.00 + 2.00)	12.80 (1.50-13.40)	3400 (200-3560)	3.76	A
(15 + 50) + (15 + 15 + 18)	(1.22 + 4.08) + (1.50 + 1.50 + 1.80)	10.10 (1.50-11.90)	2970 (200-3360)	3.40	A	(1.60 + 5.20) + (2.00 + 2.00 + 2.50)	13.30 (1.50-13.80)	3440 (200-3770)	3.87	A
(15 + 50) + (15 + 15 + 25)	(1.22 + 4.08) + (1.45 + 1.45 + 2.41)	10.60 (1.50-11.90)	3100 (200-3340)	3.42	A	(1.60 + 5.20) + (1.72 + 1.72 + 3.36)	13.60 (1.50-14.40)	3500 (200-3870)	3.89	A
(15 + 50) + (15 + 15 + 35)	(1.22 + 4.08) + (1.22 + 1.22 + 2.85)	10.60 (1.50-11.90)	3100 (200-3360)	3.42	A	(1.60 + 5.20) + (1.55 + 1.55 + 3.71)	13.60 (1.50-14.40)	3500 (200-3870)	3.89	A
(15 + 50) + (15 + 15 + 50)	(1.22 + 4.08) + (0.99 + 0.99 + 3.31)	10.60 (1.50-11.90)	3100 (200-3880)	3.42	A	(1.60 + 5.20) + (1.30 + 1.30 + 4.21)	13.60 (1.50-14.40)	3500 (200-3870)	3.89	A
(15 + 50) + (15 + 18 + 18)	(1.22 + 4.08) + (1.50 + 1.80 + 1.80)	10.40 (1.50-11.90)	3050 (200-3340)	3.41	A	(1.60 + 5.20) + (1.94 + 2.43 + 2.43)	13.60 (1.50-14.40)	3500 (200-3870)	3.89	A
(15 + 50) + (15 + 18 + 25)	(1.22 + 4.08) + (1.37 + 1.64 + 2.28)	10.60 (1.50-11.90)	3100 (200-3880)	3.42	A	(1.60 + 5.20) + (1.62 + 2.02 + 3.16)	13.60 (1.50-14.40)	3500 (200-3870)	3.89	A
(15 + 50) + (15 + 18 + 35)	(1.22 + 4.08) + (1.17 + 1.40 + 2.73)	10.60 (1.50-11.90)	3100 (200-3880)	3.42	A	(1.60 + 5.20) + (1.46 + 1.83 + 3.51)	13.60 (1.50-14.40)	3500 (200-3870)	3.89	A
(15 + 50) + (15 + 18 + 50)	(1.22 + 4.08) + (0.96 + 1.15 + 3.19)	10.60 (1.50-11.90)	3100 (200-3880)	3.42	A	(1.60 + 5.20) + (1.24 + 1.55 + 4.02)	13.60 (1.50-14.40)	3500 (200-3870)	3.89	A
(15 + 50) + (15 + 25 + 25)	(1.22 + 4.08) + (1.22 + 2.04 + 2.04)	10.60 (1.50-11.90)	3100 (200-3880)	3.42	A	(1.60 + 5.20) + (1.39 + 2.71 + 2.71)	13.60 (1.50-14.40)	3500 (200-3870)	3.89	A
(15 + 50) + (15 + 25 + 35)	(1.22 + 4.08) + (1.06 + 1.77 + 2.47)	10.60 (1.50-11.90)	3100 (200-3880)	3.42	A	(1.60 + 5.20) + (1.27 + 2.48 + 3.05)	13.60 (1.50-14.40)	3500 (200-3870)	3.89	A
(15 + 50) + (15 + 35 + 35)	(1.22 + 4.08) + (0.94 + 2.18 + 2.18)	10.60 (1.50-11.90)	3100 (200-3880)	3.42	A	(1.60 + 5.20) + (1.17 + 2.81 + 2.81)	13.60 (1.50-14.40)	3500 (200-3870)	3.89	A
(15 + 50) + (18 + 18 + 18)	(1.22 + 4.08) + (1.77 + 1.77 + 1.77)	10.60 (1.50-11.90)	3100 (200-3880)	3.42	A	(1.60 + 5.20) + (2.27 + 2.27 + 2.27)	13.60 (1.50-14.40)	3500 (200-3870)	3.89	A
(15 + 50) + (18 + 18 + 25)	(1.22 + 4.08) + (1.56 + 1.56 + 2.17)	10.60 (1.50-12.30)	3100 (200-3880)	3.42	A	(1.60 + 5.20) + (1.91 + 1.91 + 2.98)	13.60 (1.50-14.40)	3500 (200-3870)	3.89	A
(15 + 50) + (18 + 18 + 35)	(1.22 + 4.08) + (1.34 + 1.34 + 2.61)	10.60 (1.50-12.50)	3100 (200-3880)	3.42	A	(1.60 + 5.20) + (1.73 + 1.73 + 3.33)	13.60 (1.50-14.40)	3500 (200-3870)	3.89	A
(15 + 50) + (18 + 18 + 50)	(1.22 + 4.08) + (1.11 + 1.11 + 3.08)	10.60 (1.50-12.50)	3100 (200-3880)	3.42	A	(1.60 + 5.20) + (1.48 + 1.48 + 3.84)	13.60 (1.50-14.40)	3500 (200-3870)	3.89	A
(15 + 50) + (18 + 25 + 25)	(1.22 + 4.08) + (1.40 + 1.95 + 1.95)	10.60 (1.50-12.50)	3100 (200-3880)	3.42	A	(1.60 + 5.20) + (1.65 + 2.57 + 2.57)	13.60 (1.50-14.40)	3500 (200-3870)	3.89	A
(15 + 50) + (18 + 25 + 35)	(1.22 + 4.08) + (1.22 + 1.70 + 2.38)	10.60 (1.50-12.50)	3100 (200-3880)	3.42	A	(1.60 + 5.20) + (1.52 + 2.37 + 2.91)	13.60 (1.50-14.40)	3500 (200-3870)	3.89	A
(15 + 50) + (18 + 35 + 35)	(1.22 + 4.08) + (1.08 + 2.11 + 2.11)	10.60 (1.50-12.50)	3100 (200-3880)	3.42	A	(1.60 + 5.20) + (1.40 + 2.70 + 2.70)	13.60 (1.50-14.40)	3500 (200-3870)	3.89	A
(15 + 50) + (25 + 25 + 25)	(1.22 + 4.08) + (1.77 + 1.77 + 1.77)	10.60 (1.50-12.50)	3100 (200-3880)	3.42	A	(1.60 + 5.20) + (2.27 + 2.27 + 2.27)	13.60 (1.50-14.40)	3500 (200-3870)	3.89	A
(15 + 50) + (25 + 25 + 35)	(1.22 + 4.08) + (1.56 + 1.56 + 2.18)	10.60 (1.50-12.50)	3100 (200-3880)	3.42	A	(1.60 + 5.20) + (2.00 + 2.00 + 2.80)	13.60 (1.50-14.40)	3500 (200-3870)	3.89	A
(18 + 18) + (18 + 18 + 18)	(1.80 + 1.80) + (1.77 + 1.77 + 1.77)	8.90 (1.50-10.00)	2630 (200-3880)	3.38	A	(2.50 + 2.50) + (2.27 + 2.27 + 2.27)	11.80 (1.50-12.40)	2970 (200-3410)	3.97	B
(18 + 18) + (18 + 18 + 25)	(1.80 + 1.80) + (1.56 + 1.56 + 2.17)	8.90 (1.50-10.40)	2630 (200-3880)	3.38	A	(2.50 + 2.50) + (1.91 + 1.91 + 2.98)	11.80 (1.50-12.40)	2970 (200-3410)	3.97	B
(18 + 35) + (18 + 18 + 18)	(1.80 + 3.50) + (1.77 + 1.77 + 1.77)	10.60 (1.50-11.60)	3100 (200-3880)	3.42	A	(2.33 + 4.47) + (2.27 + 2.27 + 2.27)	13.60 (1.50-14.40)	3530 (200-3870)	3.85	B
(18 + 50) + (18 + 18 + 18)	(1.40 + 3.90) + (1.77 + 1.77 + 1.77)	10.60 (1.50-11.90)	3100 (200-3880)	3.42	A	(1.80 + 5.00) + (2.27 + 2.27 + 2.27)	13.60 (1.50-14.40)	3500 (200-3870)	3.89	B
(18 + 25) + (18 + 18 + 25)	(1.80 + 2.50) + (1.56 + 1.56 + 2.17)	9.60 (1.50-11.00)	2830 (200-3880)	3.39	A	(2.50 + 3.90) + (1.91 + 1.91 + 2.98)	13.20 (1.50-13.50)	3380 (200-3780)	3.91	B
(18 + 35) + (18 + 18 + 25)	(1.80 + 3.50) + (1.56 + 1.56 + 2.17)	10.60 (1.50-12.00)	3100 (200-3880)	3.42	A	(2.33 + 4.47) + (1.91 + 1.91 + 2.98)	13.60 (1.50-14.40)	3530 (200-3870)	3.85	B
(18 + 50) + (18 + 18 + 25)	(1.40 + 3.90) + (1.56 + 1.56 + 2.17)	10.60 (1.50-12.30)	3100 (200-3880)	3.42	A	(1.80 + 5.00) + (1.91 + 1.91 + 2.98)	13.60 (1.50-14.40)	3500 (200-3870)	3.89	B
(18 + 35) + (18 + 18 + 35)	(1.80 + 3.50) + (1.34 + 1.34 + 2.61)	10.60 (1.50-12.20)	3100 (200-3880)	3.42	A	(2.33 + 4.47) + (1.73 + 1.73 + 3.33)	13.60 (1.50-14.40)	3530 (200-3870)	3.85	B
(18 + 50) + (18 + 18 + 35)	(1.40 + 3.90) + (1.34 + 1.34 + 2.61)	10.60 (1.50-12.50)	3100 (200-3880)	3.42	A	(1.80 + 5.00) + (1.73 + 1.73 + 3.33)	13.60 (1.50-14.40)	3500 (200-3870)	3.89	B
(18 + 50) + (18 + 18 + 50)	(1.40 + 3.90) + (1.11 + 1.11 + 3.08)	10.60 (1.50-12.50)	3100 (200-3880)	3.42	A	(1.80 + 5.00) + (1.48 + 1.48 + 3.84)	13.60 (1.50-14.40)	3500 (200-3870)	3.89	B
(25 + 25) + (18 + 18 + 25)	(2.50 + 2.50) + (1.56 + 1.56 + 2.17)	10.30 (1.50-12.00)	3020 (200-3880)	3.41	A	(3.40 + 3.40) + (1.91 + 1.91 + 2.98)	13.60 (1.50-14.40)	3500 (200-3870)	3.89	B

POSSIBLE COMBINATIONS OF INDOOR UNITS	COOLING MODE					HEATING MODE				
	Unit power (kW)	Total power (kW)	Total Abs. power (W)	EER	Energy class	Unit power (kW)	Total power (kW)	Total Abs. power (W)	COP	Energy class
(25 + 35) + (18 + 18 + 25)	(2.21 + 3.09) + (1.56 + 1.56 + 2.17)	10.60 (1.50-12.10)	3100 (200-3880)	3.42	A	(2.83 + 3.97) + (1.91 + 1.91 + 2.98)	13.60 (1.50-14.40)	3500 (200-3870)	3.89	B
(18 + 50) + (18 + 25 + 25)	(1.40 + 3.90) + (1.40 + 1.95 + 1.95)	10.60 (1.50-12.50)	3100 (200-3880)	3.42	A	(1.80 + 5.00) + (1.65 + 2.57 + 2.57)	13.60 (1.50-14.40)	3500 (200-3870)	3.89	B
(35 + 35) + (18 + 18 + 25)	(2.65 + 2.65) + (1.56 + 1.56 + 2.17)	10.60 (1.50-12.30)	3100 (200-3880)	3.42	A	(3.40 + 3.40) + (1.91 + 1.91 + 2.98)	13.60 (1.50-14.40)	3470 (200-3870)	3.92	B
(18 + 50) + (18 + 25 + 35)	(1.40 + 3.90) + (1.22 + 1.70 + 2.38)	10.60 (1.50-12.50)	3100 (200-3880)	3.42	A	(1.80 + 5.00) + (1.52 + 2.37 + 2.91)	13.60 (1.50-14.40)	3500 (200-3870)	3.89	B
(35 + 35) + (18 + 18 + 35)	(2.65 + 2.65) + (1.34 + 1.34 + 2.61)	10.60 (1.50-12.50)	3100 (200-3860)	3.42	A	(3.40 + 3.40) + (1.73 + 1.73 + 3.33)	13.60 (1.50-14.40)	3470 (200-3870)	3.92	B
(25 + 25) + (18 + 25 + 25)	(2.50 + 2.50) + (1.40 + 1.95 + 1.95)	10.30 (1.50-12.20)	3020 (200-3880)	3.41	A	(3.40 + 3.40) + (1.65 + 2.57 + 2.57)	13.60 (1.50-14.40)	3500 (200-3870)	3.89	B
(25 + 35) + (18 + 25 + 25)	(2.21 + 3.09) + (1.40 + 1.95 + 1.95)	10.60 (1.50-12.30)	3100 (200-3880)	3.42	A	(2.83 + 3.97) + (1.65 + 2.57 + 2.57)	13.60 (1.50-14.40)	3500 (200-3870)	3.89	B
(18 + 50) + (25 + 25 + 25)	(1.40 + 3.90) + (1.77 + 1.77 + 1.77)	10.60 (1.50-12.50)	3100 (200-3880)	3.42	A	(1.80 + 5.00) + (2.27 + 2.27 + 2.27)	13.60 (1.50-14.40)	3500 (200-3870)	3.89	B
(35 + 35) + (18 + 25 + 25)	(2.65 + 2.65) + (1.40 + 1.95 + 1.95)	10.60 (1.50-12.50)	3100 (200-3880)	3.42	A	(3.40 + 3.40) + (1.65 + 2.57 + 2.57)	13.60 (1.50-14.40)	3470 (200-3870)	3.92	B
(25 + 50) + (18 + 25 + 35)	(1.77 + 3.53) + (1.22 + 1.70 + 2.38)	10.60 (1.50-12.50)	3100 (200-3880)	3.42	A	(2.55 + 4.25) + (1.52 + 2.37 + 2.91)	13.60 (1.50-14.40)	3470 (200-3870)	3.92	B
(35 + 35) + (18 + 25 + 35)	(2.65 + 2.65) + (1.22 + 1.70 + 2.38)	10.60 (1.50-12.50)	3100 (200-3880)	3.42	A	(3.40 + 3.40) + (1.52 + 2.37 + 2.91)	13.60 (1.50-14.40)	3470 (200-3870)	3.92	B
(35 + 35) + (18 + 35 + 35)	(2.65 + 2.65) + (1.08 + 2.11 + 2.11)	10.60 (1.50-12.50)	3100 (200-3880)	3.42	A	(3.40 + 3.40) + (1.40 + 2.70 + 2.70)	13.60 (1.50-14.40)	3470 (200-3870)	3.92	B
(25 + 25) + (25 + 25 + 25)	(2.50 + 2.50) + (1.77 + 1.77 + 1.77)	10.30 (1.50-12.20)	3020 (200-3880)	3.41	A	(3.40 + 3.40) + (2.27 + 2.27 + 2.27)	13.60 (1.50-14.40)	3500 (200-3870)	3.89	B
(25 + 35) + (25 + 25 + 25)	(2.21 + 3.09) + (1.77 + 1.77 + 1.77)	10.60 (1.50-12.30)	3100 (200-3880)	3.42	A	(2.83 + 3.97) + (2.27 + 2.27 + 2.27)	13.60 (1.50-14.40)	3500 (200-3870)	3.89	B
(25 + 50) + (25 + 25 + 25)	(1.77 + 3.53) + (1.77 + 1.77 + 1.77)	10.60 (1.50-12.50)	3100 (200-3860)	3.42	A	(2.55 + 4.25) + (2.27 + 2.27 + 2.27)	13.60 (1.50-14.40)	3470 (200-3870)	3.92	B
(35 + 35) + (25 + 25 + 25)	(2.65 + 2.65) + (1.77 + 1.77 + 1.77)	10.60 (1.50-12.50)	3100 (200-3880)	3.42	A	(3.40 + 3.40) + (2.27 + 2.27 + 2.27)	13.60 (1.50-14.40)	3470 (200-3870)	3.92	B
(25 + 50) + (25 + 25 + 35)	(1.77 + 3.53) + (1.56 + 1.56 + 2.18)	10.60 (1.50-12.50)	3100 (200-3860)	3.42	A	(2.55 + 4.25) + (2.00 + 2.00 + 2.80)	13.60 (1.50-14.40)	3470 (200-3870)	3.92	B
(35 + 35) + (25 + 25 + 35)	(2.65 + 2.65) + (1.56 + 1.56 + 2.18)	10.60 (1.50-12.50)	3100 (200-3880)	3.42	A	(3.40 + 3.40) + (2.00 + 2.00 + 2.80)	13.60 (1.50-14.40)	3470 (200-3870)	3.92	B
(35 + 50) + (25 + 25 + 35)	(2.18 + 3.12) + (1.56 + 1.56 + 2.18)	10.60 (1.50-13.20)	3100 (200-3880)	3.42	A	(2.89 + 3.91) + (2.00 + 2.00 + 2.80)	13.60 (1.50-14.40)	3470 (200-3870)	3.92	B
(15 + 15 + 15) + (15 + 15 + 15)	(1.50 + 1.50 + 1.50) + (1.50 + 1.50 + 1.50)	9.00 (1.50-10.00)	2640 (200-3360)	3.41	A	(2.00 + 2.00 + 2.00) + (2.00 + 2.00 + 2.00)	12.00 (1.50-12.40)	3160 (200-3100)	3.80	A
(15 + 15 + 15) + (15 + 15 + 18)	(1.50 + 1.50 + 1.50) + (1.50 + 1.50 + 1.80)	9.30 (1.50-11.00)	2740 (200-3360)	3.39	A	(2.00 + 2.00 + 2.00) + (2.00 + 2.00 + 2.50)	12.50 (1.50-12.80)	3200 (200-3310)	3.91	A
(15 + 15 + 15) + (15 + 15 + 25)	(1.50 + 1.50 + 1.50) + (1.45 + 1.45 + 2.41)	9.80 (1.50-11.00)	2870 (200-3340)	3.41	A	(2.00 + 2.00 + 2.00) + (1.72 + 1.72 + 3.36)	12.80 (1.50-13.40)	3260 (200-3410)	3.93	A
(15 + 15 + 15) + (15 + 15 + 35)	(1.50 + 1.50 + 1.50) + (1.22 + 1.22 + 2.85)	9.80 (1.50-11.00)	2870 (200-3360)	3.41	A	(2.00 + 2.00 + 2.00) + (1.55 + 1.55 + 3.71)	12.80 (1.50-13.40)	3260 (200-3410)	3.93	A
(15 + 15 + 15) + (15 + 15 + 50)	(1.50 + 1.50 + 1.50) + (0.99 + 0.99 + 3.31)	9.80 (1.50-11.00)	2870 (200-3880)	3.41	A	(2.00 + 2.00 + 2.00) + (1.30 + 1.30 + 4.21)	12.80 (1.50-13.40)	3260 (200-3410)	3.93	A
(15 + 15 + 15) + (15 + 18 + 18)	(1.50 + 1.50 + 1.50) + (1.50 + 1.80 + 1.80)	9.60 (1.50-11.00)	2820 (200-3340)	3.40	A	(2.00 + 2.00 + 2.00) + (1.94 + 2.43 + 2.43)	12.80 (1.50-13.40)	3260 (200-3410)	3.93	A
(15 + 15 + 15) + (15 + 18 + 25)	(1.50 + 1.50 + 1.50) + (1.37 + 1.64 + 2.28)	9.80 (1.50-11.00)	2870 (200-3880)	3.41	A	(2.00 + 2.00 + 2.00) + (1.62 + 2.02 + 3.16)	12.80 (1.50-13.40)	3260 (200-3410)	3.93	A
(15 + 15 + 15) + (15 + 18 + 35)	(1.50 + 1.50 + 1.50) + (1.17 + 1.40 + 2.73)	9.80 (1.50-11.00)	2870 (200-3880)	3.41	A	(2.00 + 2.00 + 2.00) + (1.46 + 1.83 + 3.51)	12.80 (1.50-13.40)	3260 (200-3410)	3.93	A
(15 + 15 + 15) + (15 + 18 + 50)	(1.50 + 1.50 + 1.50) + (0.96 + 1.15 + 3.19)	9.80 (1.50-11.00)	2870 (200-3880)	3.41	A	(2.00 + 2.00 + 2.00) + (1.24 + 1.55 + 4.02)	12.80 (1.50-13.40)	3260 (200-3410)	3.93	A
(15 + 15 + 15) + (15 + 25 + 25)	(1.50 + 1.50 + 1.50) + (1.22 + 2.04 + 2.04)	9.80 (1.50-11.00)	2870 (200-3880)	3.41	A	(2.00 + 2.00 + 2.00) + (1.39 + 2.71 + 2.71)	12.80 (1.50-13.40)	3260 (200-3410)	3.93	A
(15 + 15 + 15) + (15 + 25 + 35)	(1.50 + 1.50 + 1.50) + (1.06 + 1.77 + 2.47)	9.80 (1.50-11.00)	2870 (200-3880)	3.41	A	(2.00 + 2.00 + 2.00) + (1.27 + 2.48 + 3.05)	12.80 (1.50-13.40)	3260 (200-3410)	3.93	A
(15 + 15 + 15) + (15 + 35 + 35)	(1.50 + 1.50 + 1.50) + (0.94 + 2.18 + 2.18)	9.80 (1.50-11.00)	2870 (200-3880)	3.41	A	(2.00 + 2.00 + 2.00) + (1.17 + 2.81 + 2.81)	12.80 (1.50-13.40)	3260 (200-3410)	3.93	A
(15 + 15 + 15) + (18 + 18 + 18)	(1.50 + 1.50 + 1.50) + (1.77 + 1.77 + 1.77)	9.80 (1.50-11.00)	2870 (200-3880)	3.41	A	(2.00 + 2.00 + 2.00) + (2.27 + 2.27 + 2.27)	12.80 (1.50-13.40)	3260 (200-3410)	3.93	A
(15 + 15 + 15) + (18 + 18 + 25)	(1.50 + 1.50 + 1.50) + (1.56 + 1.56 + 2.17)	9.80 (1.50-11.40)	2870 (200-3880)	3.41	A	(2.00 + 2.00 + 2.00) + (1.91 + 1.91 + 2.98)	12.80 (1.50-13.40)	3260 (200-3410)	3.93	A
(15 + 15 + 15) + (18 + 18 + 35)	(1.50 + 1.50 + 1.50) + (1.34 + 1.34 + 2.61)	9.80 (1.50-11.60)	2870 (200-3860)	3.41	A	(2.00 + 2.00 + 2.00) + (1.73 + 1.73 + 3.33)	12.80 (1.50-13.40)	3260 (200-3410)	3.93	A
(15 + 15 + 15) + (18 + 18 + 50)	(1.50 + 1.50 + 1.50) + (1.11 + 1.11 + 3.08)	9.80 (1.50-11.60)	2870 (200-3880)	3.41	A	(2.00 + 2.00 + 2.00) + (1.48 + 1.48 + 3.84)	12.80 (1.50-13.40)	3260 (200-3410)	3.93	A
(15 + 15 + 15) + (18 + 25 + 25)	(1.50 + 1.50 + 1.50) + (1.40 + 1.95 + 1.95)	9.80 (1.50-11.60)	2870 (200-3880)	3.41	A	(2.00 + 2.00 + 2.00) + (1.65 + 2.57 + 2.57)	12.80 (1.50-13.40)	3260 (200-3410)	3.93	A
(15 + 15 + 15) + (18 + 25 + 35)	(1.50 + 1.50 + 1.50) + (1.22 + 1.70 + 2.38)	9.80 (1.50-11.60)	2870 (200-3860)	3.41	A	(2.00 + 2.00 + 2.00) + (1.52 + 2.37 + 2.91)	12.80 (1.50-13.40)	3260 (200-3410)	3.93	A
(15 + 15 + 15) + (18 + 35 + 35)	(1.50 + 1.50 + 1.50) + (1.08 + 2.11 + 2.11)	9.80 (1.50-11.60)	2870 (200-3880)	3.41	A	(2.00 + 2.00 + 2.00) + (1.40 + 2.70 + 2.70)	12.80 (1.50-13.40)	3260 (200-3410)	3.93	A
(15 + 15 + 15) + (25 + 25 + 25)	(1.50 + 1.50 + 1.50) + (1.77 + 1.77 + 1.77)	9.80 (1.50-11.60)	2870 (200-3880)	3.41	A	(2.00 + 2.00 + 2.00) + (2.27 + 2.27 + 2.27)	12.80 (1.50-13.40)	3260 (200-3410)	3.93	A
(15 + 15 + 15) + (25 + 25 + 35)	(1.50 + 1.50 + 1.50) + (1.56 + 1.56 + 2.18)	9.80 (1.50-11.60)	2870 (200-3880)	3.41	A	(2.00 + 2.00 + 2.00) + (2.00 + 2.00 + 2.80)	12.80 (1.50-13.40)	3260 (200-3410)	3.93	A
(15 + 15 + 18) + (15 + 15 + 15)	(1.50 + 1.50 + 1.80) + (1.50 + 1.50 + 1.50)	9.30 (1.50-11.00)	2740 (200-3360)	3.39	A	(2.00 + 2.00 + 2.50) + (2.00 + 2.00 + 2.00)	12.50 (1.50-12.80)	3200 (200-3310)	3.91	A
(15 + 15 + 18) + (15 + 15 + 18)	(1.50 + 1.50 + 1.80) + (1.50 + 1.50 + 1.80)	9.60 (1.50-12.00)	2840 (200-3360)	3.38	A	(2.00 + 2.00 + 2.50) + (2.00 + 2.00 + 2.50)	13.00 (1.50-13.20)	3240 (200-3520)	4.01	A
(15 + 15 + 18) + (15 + 15 + 25)	(1.50 + 1.50 + 1.80) + (1.45 + 1.45 + 2.41)	10.10 (1.50-12.00)	2970 (200-3340)	3.40	A	(2.00 + 2.00 + 2.50) + (1.72 + 1.72 + 3.36)	13.30 (1.50-13.80)	3300 (200-3620)	4.03	A

















Tanatorio Bidasoa  
 RAI Cassette Range  
 More info: [www.hitachiircon.es](http://www.hitachiircon.es)



◀ **RAM-110NP6B  
 FRIGORIFIC LENGTHS**

(L1 + L2 + L3) y (L4 + L5 + L6) = Maximum 45 m.  
 (L2 + L3) y (L5 + L6) = Maximum 35 m.  
 L1 = 25 m ; L2 = 25 m ; L3 = 25 m ; L4 = 25 m ; L5 = 25 m ; L6 = 25 m.  
 Maximum height between the highest indoor unit and the lowest indoor unit: 5 m.  
 Preload for 35 m (using compressor).  
 Provide 20 g/m of refrigerant beyond 30 m.  
 Always connect the most powerful indoor unit to the lowest connection.

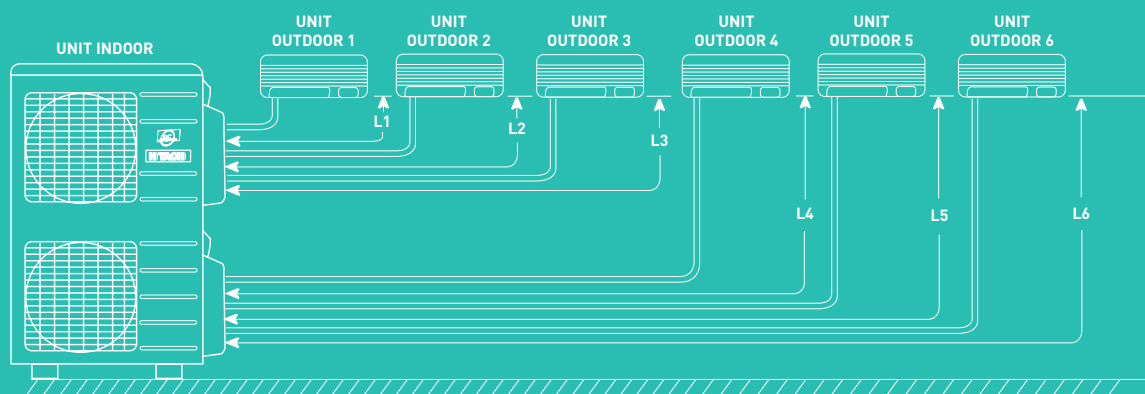





# HEATING AND DHW



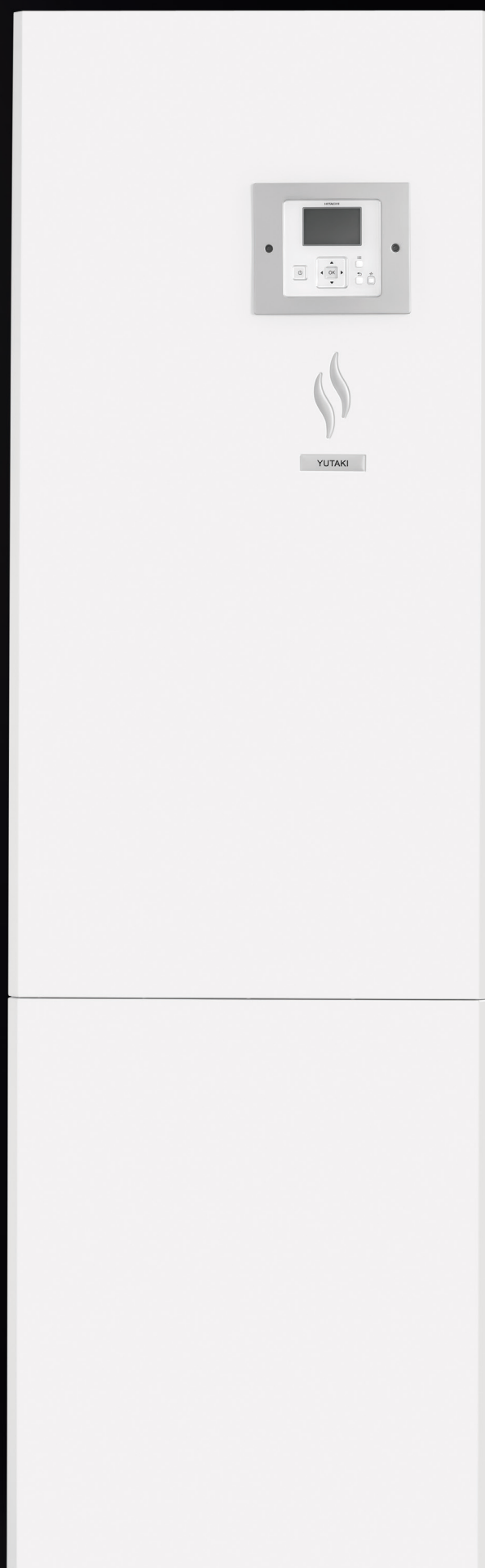



# HEAT PUMPS

## AIR/WATER

<b>HEAT PUMPS</b>	<b>76</b>
<hr/>	
AIR/WATER	
<hr/>	
YUTAKI S80	79
<hr/>	
YUTAKI S	84
<hr/>	
YUTAKI S COMBI	87
<hr/>	
YUTAKI M	91
<hr/>	
YUTAMPO	93



EASY INSTALLATION AND  
SIMPLE MAINTENANCE  
**BECAUSE THEY SHARE  
THE SAME COMPONENTS**

**NEW LIGHTER, MORE  
COMPACT MODELS**  
THAT AIR CONDITIONS  
SMALLER SURFACES  
WITHOUT SACRIFICING  
POWER AND  
EFFICIENCY

**70% NATURAL  
ENERGY 30%  
ELECTRICITY**  
MORE ENERGY, LESS  
ELECTRICITY



ENERGY CLASS A+++\*

*\*Depending on model*



# HEATING AND DHW



More information  
about compatible  
controls and  
accessories

Page 192

The Yutaki range has been completely redesigned to achieve great savings in the electric bill, as well as to facilitate its installation and maintenance

### New Cooling Kit

It makes the Yutaki range reversible, allowing it to work with cooling and/or heating.

### Yutaki in the winter

It absorbs heat from outdoor air, converts it into energy and transmits it to the entire heating circuit.

### Yutaki in the summer

It absorbs the heat from the indoor air and converts it into energy, achieving great savings.

### A good deal for all types of budgets

Energy efficiency achieves significant savings in electricity consumption.

### Maximum comfort, maximum technology

It avoids unnecessary consumption since DC inverter technology accurately adjusts the power.

**Unique control for all ranges** and common set-up configuration for all.

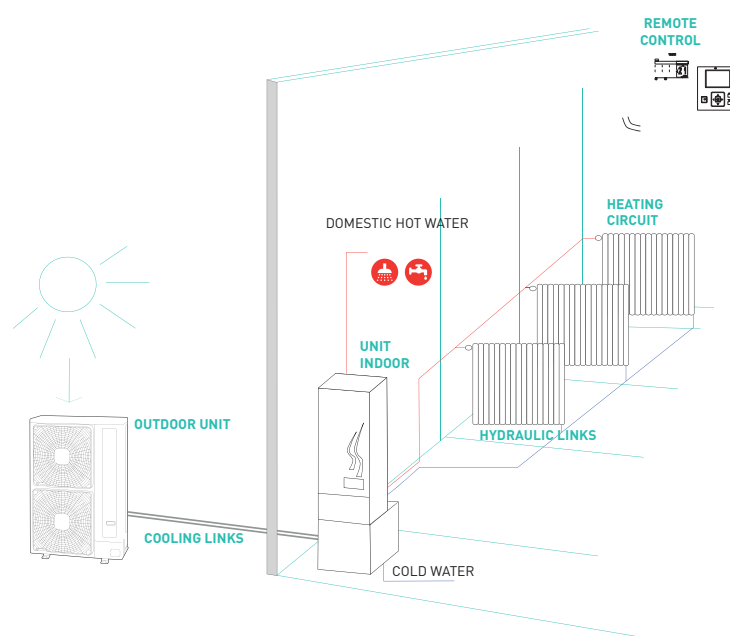



## HEATING AND DHW AIR/WATER

# YUTAKI S80

RWH-4~6(V)NF(W)E



### CHARACTERISTICS

#### Easy installation and maintenance

Its new design allows easy access to water and refrigerant connections.

#### Maximum heating capacity

It heats the water up to **80°C** even with extreme outdoor temperatures, down to **-20°C**.

#### RWH(V)-NFE Indoor Unit

Compatible with all DHW tanks.

#### New LCD controller

Easy to use, compatible with the new wireless control and with weekly programs.

#### Applications

Ideal for boiler replacement and for refurbishment.

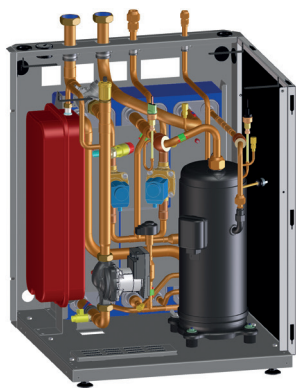

*Indoor unit with tank.*

< 2 >  
NEW  
MODELS

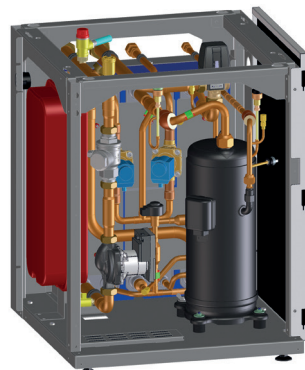

*Indoor unit without tank\*.*

*\*There is the possibility to install the DHW tank, as an accessory, beside the unit*

## YUTAKI S80

NAME OF THE SET		YUTAKI S80 4HP	YUTAKI S80 5HP	YUTAKI S80 6HP	YUTAKI S80 4HP	YUTAKI S80 5HP	YUTAKI S80 6HP	
		SINGLE PHASE			THREE-PHASE			
INDOOR UNIT		RWH-4.0VNF(W)E	RWH-5.0VNF(W)E	RWH-6.0VNF(W)E	RWH-4.0NF(W)E	RWH-5.0NF(W)E	RWH-6.0NF(W)E	
Power supply		1 ~230 V 50 Hz			3N ~400 V 50 Hz			
Sound Power <sup>(2)</sup>	dB(A)	57		58	57		58	
Dimensions	High (with connections)	751 (802)*			751 (802)*			
	Width	600			600			
	Depth	623			623			
Weight	kg	135	138		138	141		
Weight of model with DHW tank		143	146		150	155		
Pipe diameter (Liquid - Gas)	inches	3/8 - 5/8			3/8 - 5/8			
Heating Operating Range	Outdoor temperature	-25~25			-25~25			
	Water output temperature	20~80			20~80			
Operating rank range (DHW)	Outdoor temperature	-25~35			-25~35			
	Water output temperature	30~75			30~75			
Refrigerant		R-134a			R-134a			
Refrigerant charge	kg	1.90			1.90			
Compressor		Scroll DC Inverter			Scroll DC Inverter			
OUTDOOR UNIT		RAS-4WHVNP	RAS-5WHVNP	RAS-6WHVNP	RAS-4WHNP	RAS-5WHNP	RAS-6WHNP	
Absorbed nominal power	Heating 7°C outdoor / 30~35°C water <sup>(1)</sup>	kW	2.20	2.97	3.50	2.20	2.97	3.50
Absorbed nominal capacity	Heating 7°C outdoor / 30~35°C water (max) <sup>(1)</sup>	kW	11.00 (15.20)	14.00 (16.70)	16.00 (17.80)	11.00 (15.20)	14.00 (16.70)	16.00 (17.80)
COP 7°C outdoor / 30~35°C water			5.00	4.71	4.57	5.00	4.71	4.57
Nominal energy class 35°C			<b>A+++</b>	<b>A++</b>	<b>A++</b>	<b>A+++</b>	<b>A++</b>	<b>A++</b>
Power supply		1 ~230 V 50 Hz			3N ~400 V 50 Hz			
Sound Power <sup>(2)</sup>	dB(A)	63	64	65	63	64	65	
Airflow	m <sup>3</sup> /h	4800	5400	6000	4800	5400	6000	
Pipe diameter (Liquid - Gas)	inches	3/8 - 5/8			3/8 - 5/8			
Maximum length	m	75			75			
Maximum Height		30/20			30/20			
Operating ranges	°C (DB)	10~46 // -25~25 / -25~35			10~46 // -25~25 / -25~35			
Refrigerant fluid		R410			R410			
Refrigerant charge (Maximum length of pipes without load)	kg	3.30 (60)	3.40 (60)		3.30 (60)	3.40 (60)		
Compressor		Scroll DC Inverter			Scroll DC Inverter			
<b>INDOOR UNIT PRICE WITH DHW TANK</b>								
<b>INDOOR UNIT PRICE WITHOUT TANK</b>								
<b>OUTDOOR UNIT PRICE</b>								
<b>MODULE PRICE WITH 200 L DHWT WATER TANK</b>								
<b>MODULE PRICE WITH 260 L DHWT WATER TANK</b>								

\* Corresponds to the height of the unit with the minimum mounting foot height. This value can be adjusted up to +30 mm

Performance guaranteed

- (1) The nominal power for cooling and heating is based on EN14511 and on the following conditions:  
 - Cooling: Input water temperature 12°C and output water temperature 7°C; Outdoor temperature 35°C DB  
 - Heating: Input water temperature 30°C and output water temperature 35°C; Outdoor temperature 7°C DB, 6°C WB  
 - Pipe length 7.5 m; pipe Height 0 m

- (2) The sound level measurement is performed under the following conditions:  
 Outdoor temperature: 7°C (DB) / 6°C (WB)  
 Water input and output temperature: 30/35°C

The sound level measurement is performed in an anechoic camera at 1 m from the frontal surface and at 1.5 m from the ground level. The sound pressure level is carried out in a reverberating chamber according to EN12102. The environmental conditions are those specified in standard EN 14511.

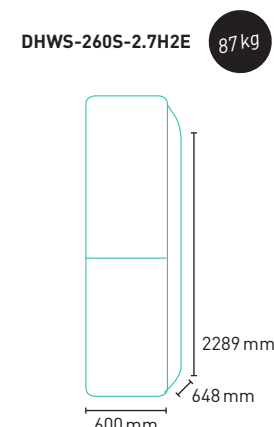
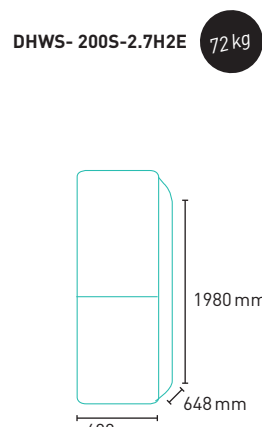
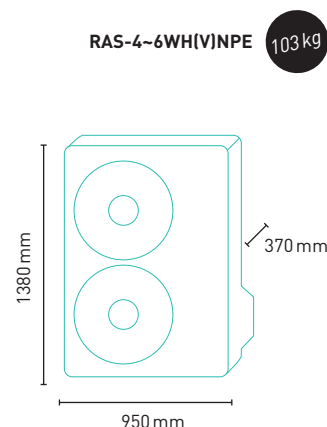
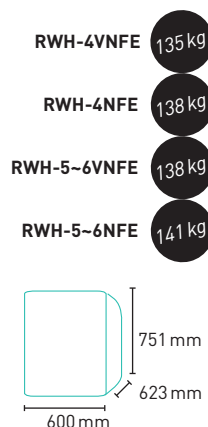

## HEATING AND DHW AIR/WATER

# YUTAKI S80

RWH-4~6[V]NF[W]E

### THE IDEAL HEAT PUMP FOR THE REPLACEMENT OF BOILERS, CAPABLE OF GENERATING UP TO 80°C USING RENEWABLE ENERGY

Reduction of heating bills up to 60% and CO<sub>2</sub> emissions by 50% compared to boiler systems, as it transforms the outdoor air into heat. Each kW of electricity used to power the heat pump can provide up to 5 kW of power for heating. This results in a reduction of heating bills by up to 60% and a 50% reduction in CO<sub>2</sub> emissions compared to boiler systems.

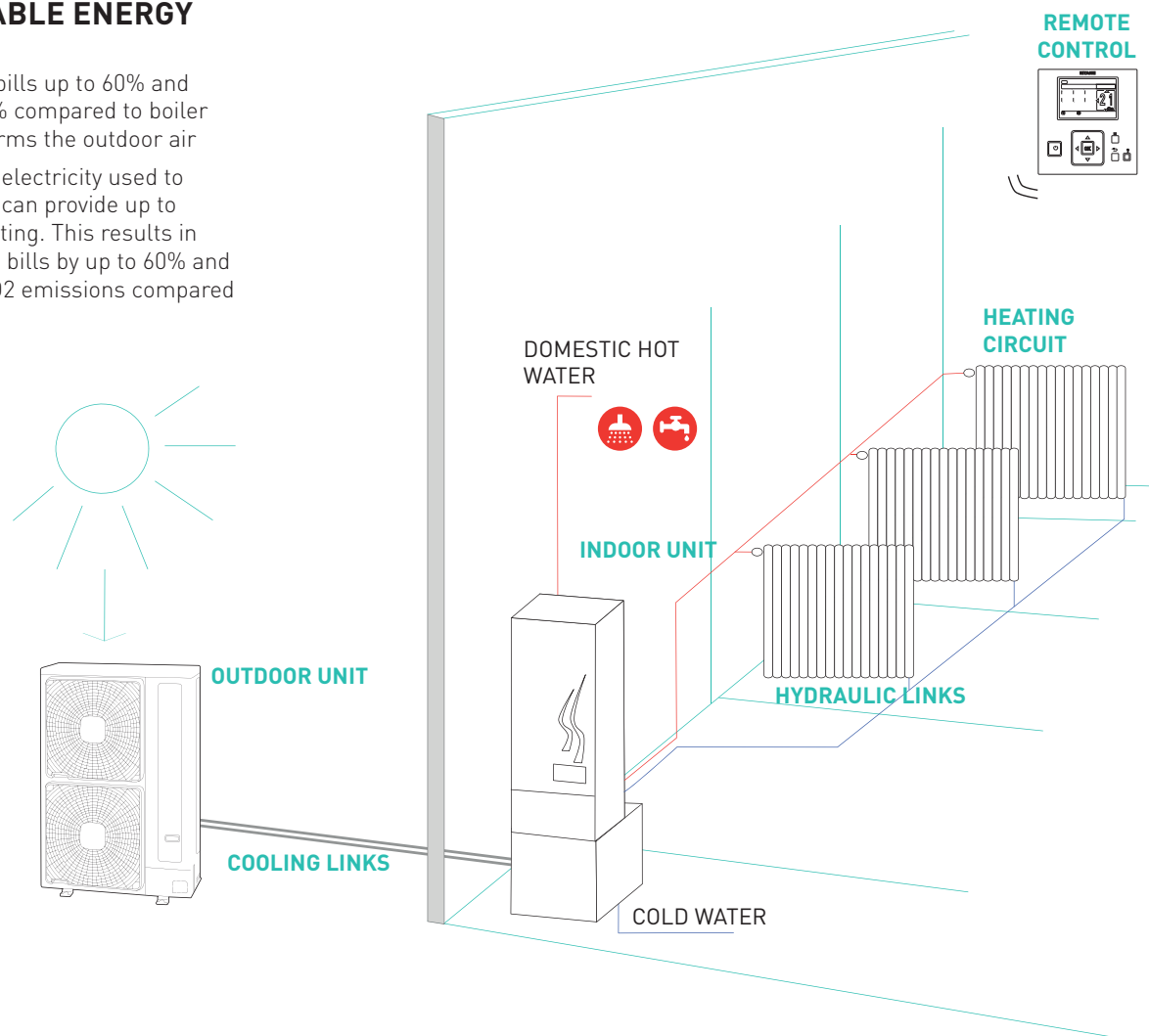

### “SMART CASCADE” CYCLE

Under normal ambient conditions and when heating needs are lower, the smart cascade cycle adjusts automatic operation and uses a single cycle (R410A).

When the heating needs are higher, the second cycle (R134A) automatically starts operating.

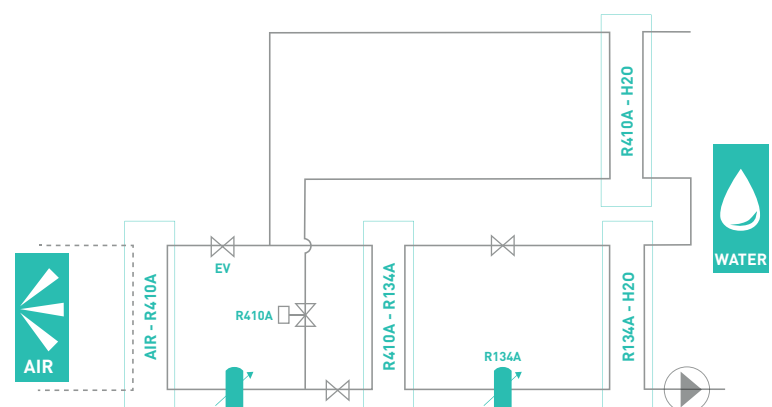



## SMART CONTROL

The control with LCD screen and thermostat create a unique system with functions such as:

- Heating / DHW / solar panel / pool
- Alarm code history for maintenance
- Emergency mode
- Range drying function
- Boiler combination
- Energy conservation mode for the water pump
- Weekly schedule for heating and domestic hot water



PC-ARFHE Control

## FOR ALL TYPES OF EXISTING INSTALLATIONS

Its flexible design allows different installation possibilities and flexible piping connection.

- Hydraulic module
- Hydraulic module + integrated Hitachi hot water tank
- Hydraulic module + Hitachi hot water tank on one side
- Hydraulic module + hot water tank

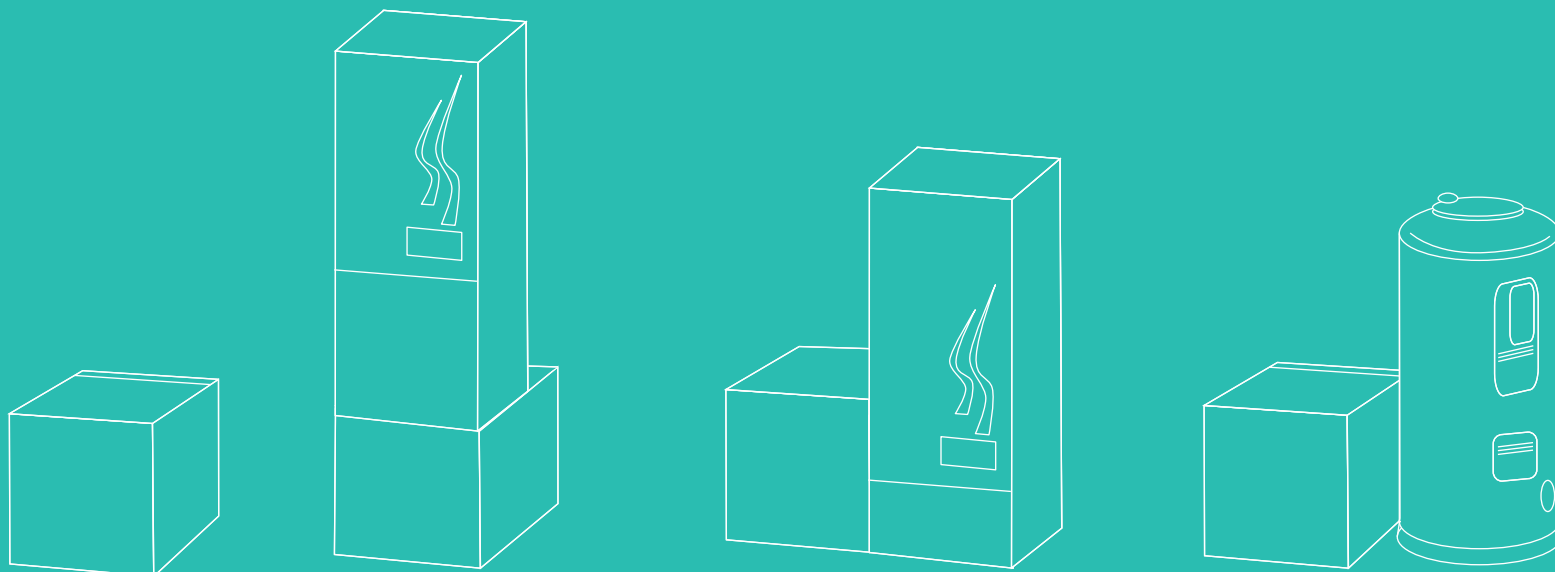

## HEATING AND DHW

### AIR/WATER INVERTER COOLING

# YUTAKI S

## RWM-2~10NE



### CHARACTERISTICS

#### Wide range of powers from 2~10 HP

##### Applications

New model 2.5 HP, for light applications. COP up to 5.25 perfect for new construction and renovation with boiler replacement. Compatible with radiant floor heating, radiators and fan coils.

#### Broad operating ranges

In heating mode, the water output fluctuates between 20~60°C and in cooling mode between 5~22°C.

#### New LCD PC-ARFHE controller

Easy to use with weekly programs.

#### Reduced dimensions

The 2~3 HP models can be installed inside the kitchen doors.

#### Maximum efficiency

It improves performance and energy efficiency thanks to the combination of the Scroll compressor, plate exchanger and the energy-saving water pump.

#### All in one

Cooling, heating and DHW. Compatible with **Cooling Kit**.

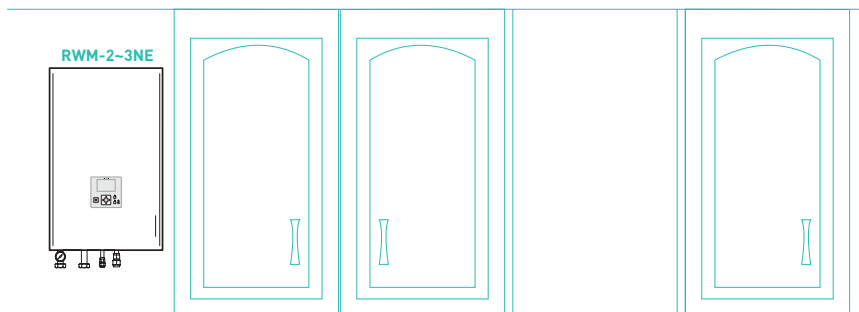

# YUTAKI S

NAME OF THE SET			YUTAKI S 2HP	YUTAKI S 2.5HP	YUTAKI S 3HP	YUTAKI S 4HP	YUTAKI S 5HP	YUTAKI S 6HP
			SINGLE PHASE					
INDOOR UNIT			RWM-2.0NE	RWM-2.5NE	RWM-3.0NE	RWM-4.0NE	RWM-5.0NE	RWM-6.0NE
Power supply			1 ~230 V 50 Hz			1 ~230 V 50 Hz / 3 N ~400 V 50 Hz		
Sound Power <sup>(2)</sup>			dB(A)			37		
Pipe diameter (Liquid - Gas)			inches			1/4 - 5/8		
Heating Operating Range			Outdoor temperature °C (DB)			-15-25		
			Water output temperature °C			20-55		
Cooling Operating Range			Outdoor temperature °C (DB)			-25-25		
			Water output temperature °C			20-60		
Operating rank range (DHW)			Outdoor temperature °C (DB)			10-46		
			Water output temperature °C			5-22		
Operating rank range (DHW)			Outdoor temperature °C (DB)			-15-35		
			Water output temperature °C			-25-35		
Operating rank range (DHW)			Water output temperature °C			30-75		
OUTDOOR UNIT			RAS-2WHVNP	RAS-2.5WHVNP	RAS-3WHVNP	RAS-4WHVNPE	RAS-5WHVNPE	RAS-6WHVNPE
Absorbed nominal power			Heating: 7°C outdoor / 30-35°C water <sup>(1)</sup> kW			0.82		
			Cooling: 7°C outdoor / 30-35°C water <sup>(1)</sup> kW			1.25		
Absorbed nominal capacity			Heating: 7°C outdoor / 30-35°C water (max) <sup>(1)</sup> kW			1.65		
			Cooling: 7°C outdoor / 30-35°C water <sup>(1)</sup> kW			2.20		
COP 7°C outdoor / 30-35°C water			5.25			4.80		
EER 35°C outdoor / 7-12°C water			3.12			3.15		
Nominal energy class 35°C			A+++			A+++		
Power supply			1 ~230 V 50 Hz					
Sound Power <sup>(2)</sup>			dB(A)			59		
Airflow			m3/h			2436		
Pipe diameter (Liquid - Gas)			inches			1/4 - 1/2		
Maximum length			m			50		
Maximum Height			m			30/20		
Operating ranges			°C (DB)			10-46 // -15-25 / -15-35		
Refrigerant fluid			R410					
Refrigerant charge			kg			1.40 (30)		
Compressor			Scroll DC Inverter					
INDOOR UNIT PRICE								
OUTDOOR UNIT PRICE								
DHWT 200 L WATER TANK PRICE								
DHWT 300 L WATER TANK PRICE								

\* Corresponds to the height of the unit with the minimum mounting foot height. This value can be adjusted up to +30 mm.

(1) The nominal power for cooling and heating is based on EN14511 and on the following conditions:  
 - Cooling: Input water temperature 12°C and output water temperature 7°C; Outdoor temperature 35°C DB  
 - Heating: Input water temperature 30°C and output water temperature 35°C; Outdoor temperature 7°C DB, 6°C WB  
 - Pipe length 7.5 m; pipe Height 0 m

(2) The sound level measurement is performed under the following conditions:  
 Outdoor temperature: 7°C (DB) / 6°C (WB)  
 Water input and output temperature: 30/35°C

The sound level measurement is performed in an anechoic camera at 1 m from the frontal surface and at 1.5 m from the ground level  
 The sound pressure level is carried out in a reverberating chamber according to EN12102. The environmental conditions are those specified in standard EN 14511.

Guaranteed performance

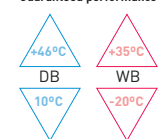

RWM-2-2.5NE 45 kg  
 RWM-3NE 46 kg

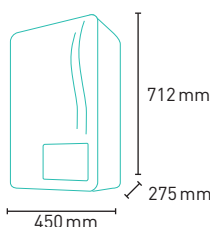

RWM-4NE 54 kg  
 RWM-5-6NE 56 kg

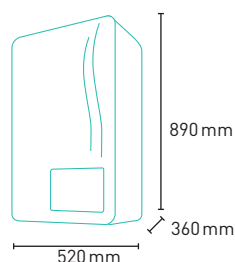

RAS-2-2.5WHVNP 43 kg  
 RAS-3WHVNP 44 kg

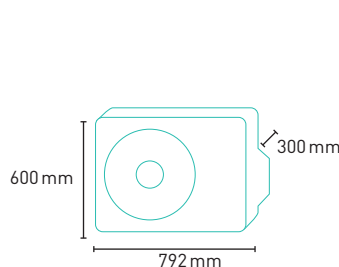

RAS-4-6WHVNPE 103 kg

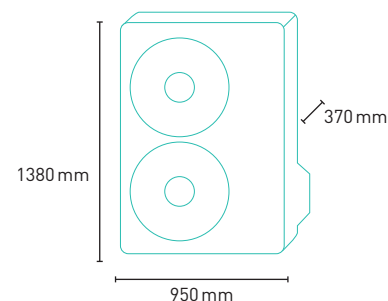

For more information about controls, see page 195.  
 Recommended prices - VAT not included, Waste Electrical and Electronic Equipment Directive (WEEE) fee not included.  
 To create the energy label visit our website [www.hitachiircon.es](http://www.hitachiircon.es) and use our Hitachi ErP AcTive Tool application.



## YUTAKI S

NAME OF THE SET			YUTAKI S 4HP	YUTAKI S 5HP	YUTAKI S 6HP	YUTAKI S 8HP	YUTAKI S 10HP
			THREE-PHASE				
INDOOR UNIT			RWM-4.0NE	RWM-5.0NE	RWM-6.0NE	RWM-8.0NE	RWM-10.0NE
Power supply			3N ~400 V 50 Hz			3N ~400 V 50 Hz	
Sound Power [2]	dB(A)		39			73	74
Pipe diameter (Liquid - Gas)	inches		3/8 - 5/8			3/8 - 1	1/2 - 1
Heating Operating Range	Outdoor temperature	°C (DB)	-25~25			-25~25	
	Water output temperature	°C	20~60			20~60	
Cooling Operating Range	Outdoor temperature	°C (DB)	10~46			10~46	
	Water output temperature	°C	5~22			5~22	
Operating rank range (DHW)	Outdoor temperature	°C (DB)	-25~35			-25~35	
	Water output temperature	°C	30~75			30~75	
OUTDOOR UNIT			RAS-4WHNPE	RAS-5WHNPE	RAS-6WHNPE	RAS-8WHNPE	RAS-10WHNPE
Absorbed nominal power	Heating: 7°C outdoor / 30~35°C water [1]	kW	2.20	2.97	3.50	4.65	5.58
	Cooling: 7°C outdoor / 30~35°C water [1]	kW	2.18	2.95	3.72	pending	pending
Absorbed nominal capacity	Heating: 7°C outdoor / 30~35°C water (max) [1]	kW	11.00 [15.20]	14.00 [16.70]	16.00 [17.80]	20.00 [25.50]	24.00 [32.00]
	Cooling: 7°C outdoor / 30~35°C water [1]	kW	7.20	9.50	10.50	pending	pending
COP 7°C outdoor / 30~35°C water			5.00	4.71	4.57	4.30	4.30
EER 35°C outdoor / 7~12°C water			3.30	3.22	2.82	pending	pending
Nominal energy class 35°C			<b>A+++</b>	<b>A++</b>	<b>A++</b>	<b>A++</b>	<b>A+</b>
Power supply			3N ~400 V 50 Hz				
Sound Power [2]	dB(A)		63	64	65	71	72
Airflow	m <sup>3</sup> /h		4800	5400	6000	7620	8040
Pipe diameter (Liquid - Gas)	inches		3/8 - 5/8			3/8 - 1	1/2 - 1
Maximum length	m		75			70	
Maximum Height			30/20				
Operating ranges	°C (DB)		10~46 // -25~25 / -25~35				
Refrigerant fluid			R410				
Refrigerant charge	kg		3.30 [60]	3.40 [60]		5.00	5.30
Compressor			Scroll DC Inverter				
INDOOR UNIT PRICE							
OUTDOOR UNIT PRICE							
DHWT 200 L WATER TANK PRICE							
DHWT 300 L WATER TANK PRICE							

\* Corresponds to the height of the unit with the minimum mounting foot height. This value can be adjusted up to +30 mm.

(1) The nominal power for cooling and heating is based on EN14511 and on the following conditions:

- Cooling: Input water temperature 12°C and output water temperature 7°C; Outdoor temperature 35°C DB
- Heating: Input water temperature 30°C and output water temperature 35°C; Outdoor temperature 7°C DB, 6°C WB
- Pipe length 7.5 m; pipe Height 0 m

(2) The sound level measurement is performed under the following conditions:

Outdoor temperature: 7°C (DB) / 6°C (WB)

Water input and output temperature: 30/35°C

The sound level measurement is performed in an anechoic camera at 1 m from the frontal surface and at 1.5 m from the ground level

The sound pressure level is carried out in a reverberating chamber according to EN12102. The environmental conditions are those specified in standard EN 14511.

Guaranteed performance

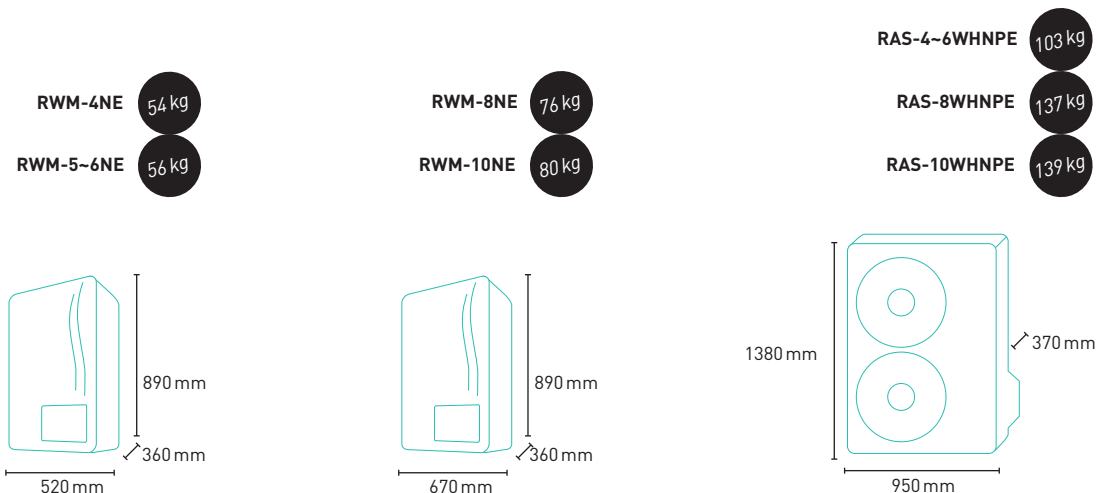
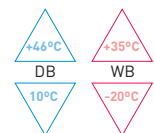

# YUTAKI S EXAMPLES OF APPLICATIONS

## APPLICATION OF HEATING/COOLING AND PRODUCTION OF DHW, WITH OR WITHOUT COMPLEMENTARY RESISTANCE. 2 SPACES

Heating of two spaces (high and low water temperature) and hot water tank, with optional room thermostat and DHW tank heated by heat pump.

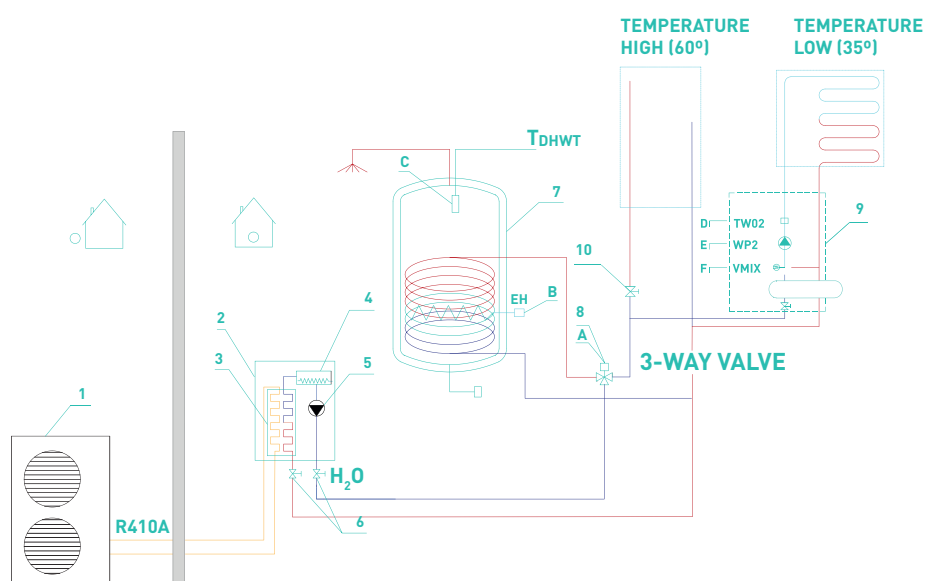

1	Outdoor unit
2	Indoor Unit
3	Heat exchanger
4	Electric resistance
5	Water pump (primary)
6	Valves (factory supplied)
7	DHWT domestic hot water tank (accessory)
8	3-Way valve for DHWT (accessory)
9	Second temperature kit (accessory)
10	Motorized valve (supplied by the installer)
A	3-way valve output signal
B	DHWT Electrical resistance signal
C	DHWT sensor signal (accessory)
D	2nd temperature sensor signal (accessory)
E	Secondary water pump signal
F	Mixing valve signal
K	Optional signal

Note: The diagrams shown here are merely informative and the responsibility for proper installation and operation lies with the installer.

**HEATING AND DHW**

HEATING AND DHW / COOLING INVERTER

**YUTAKI S COMBI**

RWD-2~6NW(S)E

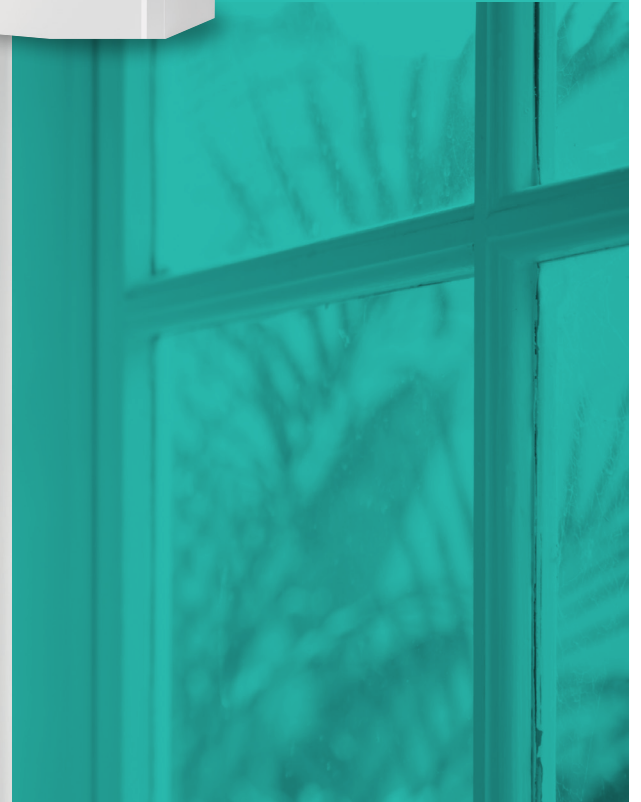
**CHARACTERISTICS****New 2.5 HP model**

For medium facilities, ideal for new construction and renovation with boiler replacement, without being oversized for the facilities.

**More ecological**

Model compatible with RWD-2~6NWSE solar panels. New 260 L solar tank.

**More possibilities**

Reversible model (cooling/heating and DHW). Compatible with the Cooling Kit.

**Wide range of power from 2~6 HP and possibility of 200 or 260 L tank.****Installation in confined spaces**

Reduction of 70% of the space required for installation, thanks to the tank included in the indoor unit.

**New control options**

New easy-to-use LCD controller with weekly programs and compatible with the new wireless control.

**Easy installation and maintenance**

Installation **Plug and Play**, labeled pipes, electrical box on the top and a large base plate.

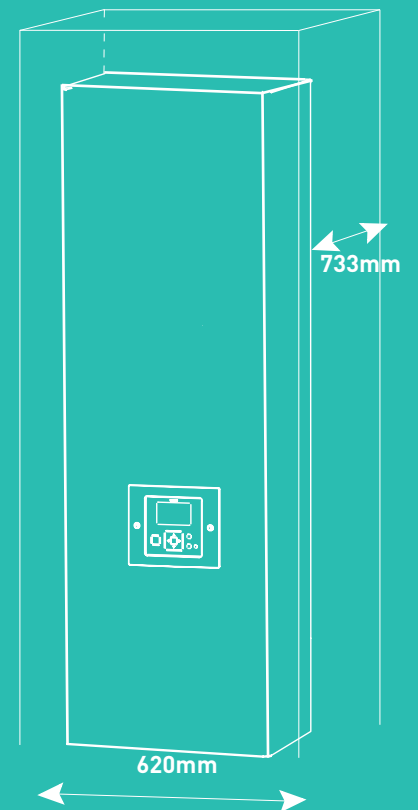



## YUTAKI S COMBI

NAME OF THE SET			YUTAKI S COMBI 2HP	YUTAKI S COMBI 2.5HP	YUTAKI S COMBI 3HP	YUTAKI S COMBI 4HP	YUTAKI S COMBI 5HP	YUTAKI S COMBI 6HP
INDOOR UNIT			SINGLE PHASE					
			RWD-2.0NW(S)E	RWD-2.5NW(S)E	RWD-3.0NW(S)E	RWD-4.0NW(S)E	RWD-5.0NW(S)E	RWD-6.0NW(S)E
Power supply			1 ~230 V 50 Hz			3N ~400 V 50 Hz		
Sound Power (2)			37			39		
Dimensions	High (with connections)		1750 (1816)*			1750 (1816)*		
	Width	mm	600			600		
	Depth		733			733		
200 L tank weight			120		121	124		126
260 L tank weight **			135		136	139		141
Pipe diameter (Liquid - Gas)			1/4 - 5/8	3/8 - 5/8		3/8 - 5/8		
Heating Operating Range	Temperature outdoors	°C (DB)	-15~25			-25~25		
	Temperature water output	°C	20~55			20~60		
Cooling Operating Range	Temperature outdoors	°C (DB)	10~46			10~46		
	Temperature water output	°C	5~22			5~22		
Operating rank range (DHW)	Temperature outdoors	°C (DB)	-15~35			-25~35		
	Temperature water output	°C	30~75			30~75		

OUTDOOR UNIT			RAS-2WHVNP	RAS-2.5WHVNP	RAS-3WHVNP	RAS-4WHVNP	RAS-5WHVNP	RAS-6WHVNP
Absorbed nominal power	Heating 7°C outdoor / 30~35°C water (1)	kW	0.82	1.25	1.65	2.20	2.97	3.50
	Cooling 7°C outdoor / 30~35°C water (1)	kW	1.22	1.59	2.18	2.18	2.95	3.72
Absorbed nominal capacity	Heating 7°C outdoor / 30~35°C water (max) (1)	kW	4.30 (7.00)	6.00 (9.00)	7.50 (11.00)	11.00 (15.20)	14.00 (16.70)	16.00 (17.80)
	Cooling 7°C outdoor / 30~35°C water (1)	kW	3.80	5.00	6.00	7.20	9.50	10.50
COP 7°C outdoor / 30~35°C water			5.25	4.80	4.55	5.00	4.71	4.57
EER 35°C outdoor / 7~12°C water			3.12	3.15	2.75	3.30	3.22	2.82
Nominal energy class 35°C			<b>A+++</b>	<b>A+++</b>	<b>A++</b>	<b>A+++</b>	<b>A++</b>	<b>A++</b>
Power supply			1 ~230 V 50 Hz					
Sound Power (2)			59	60	61	63	64	65
Airflow			2436	2436	2682	4800	5400	6000
Pipe diameter (Liquid - Gas)			1/4 - 1/2		3/8 - 5/8			
Maximum length			50			75		
Maximum Height			30/20					
Operating ranges			10~46 // -15~25 / -15~35			10~46 // -25~25 / -25~35		
Refrigerant fluid			R410					
"Refrigerant charge			1.40 (30)	1.50 (30)	1.70 (40)	3.30 (60)	3.40 (60)	3.40 (60)
"Maximum length of pipes without load"			1.40 (30)	1.50 (30)	1.70 (40)	3.30 (60)	3.40 (60)	3.40 (60)
Compressor			Scroll DC Inverter					
200 L INDOOR UNIT PRICE								
260 L INDOOR UNIT PRICE								
260 L SOLAR PANEL PRICE			For indoor unit with solar panel, contact us					
OUTDOOR UNIT PRICE								

\* Corresponds to the height of the unit with the minimum mounting foot height. This value can be adjusted up to +30m.  
 \*\* 260 L tank compatible with models RWD-2.0-6.0NWSE that allow combination with solar panel.

(1) The nominal power for cooling and heating is based on EN14511 and on the following conditions:  
 - Cooling: Input water temperature 12°C and output water temperature 7°C; Outdoor temperature 35°C DB  
 - Heating: Input water temperature 30°C and output water temperature 35°C; Outdoor temperature 7°C DB, 6°C WB  
 - Pipe length 7.5m; pipe Height 0 m"

(2) The sound level measurement is performed under the following conditions:  
 Outdoor temperature: 7°C (DB) / 6°C (WB)  
 Water entrance and exit temperature: 30/35°C

The sound level measurement is performed in an anechoic camera at 1 m from the frontal surface and at 1.5 m from the ground level  
 The sound pressure level is carried out in a reverberating chamber according to EN12102. The environmental conditions are those specified in standard EN 14511.

Guaranteed performance

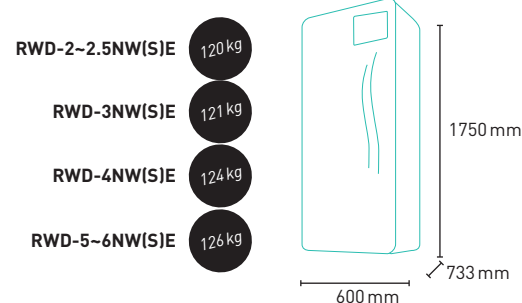
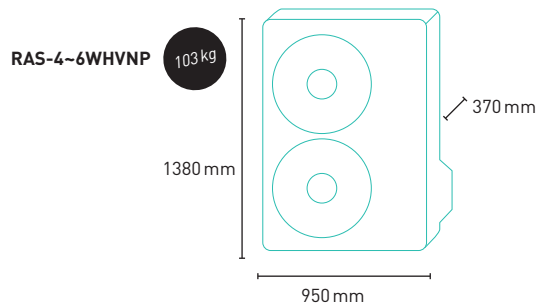
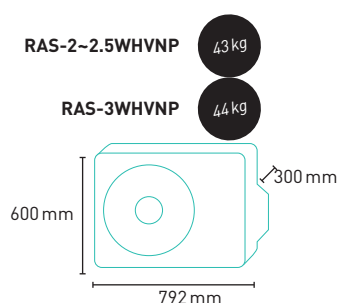
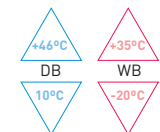

For more information about controls, see page 195.  
 Recommended prices - VAT not included, Waste Electrical and Electronic Equipment Directive (WEEE) fee not included.  
 To create the energy label visit our website [www.hitachiircon.es](http://www.hitachiircon.es) and use our Hitachi ErP AcTive Tool application.

NAME OF THE SET			YUTAKI S COMBI 4HP		YUTAKI S COMBI 5HP		YUTAKI S COMBI 6HP			
			THREE-PHASE							
INDOOR UNIT			RWD-4.0NW(S)E		RWD-5.0NW(S)E		RWD-6.0NW(S)E			
Power supply			3N ~400 V 50 Hz							
Sound Power [2]			dB(A) 39							
Dimensions			High (with connections) 1750 [1816]*							
			Width mm 600							
			Depth 733							
200 L tank weight			kg 124		126					
260 L tank weight **			kg 139		141					
Pipe diameter (Liquid - Gas)			inches 3/8 - 5/8							
Heating Operating Range			Temperature outdoors °C (DB)		-25~25					
			Temperature water output °C		20~60					
Cooling Operating Range			Temperature outdoors °C (DB)		10~46					
			Temperature water output °C		5~22					
Operating rank range (DHW)			Temperature outdoors °C (DB)		-25~35					
			Temperature water output °C		30~75					
OUTDOOR UNIT			RAS-4WHNPE		RAS-5WHNPE		RAS-6WHNPE			
Absorbed nominal power			Heating: 7°C outdoor / 30~35°C water (1) kW		2.20		2.97		3.50	
			Cooling: 7°C outdoor / 30~35°C water (1) kW		2.18		2.95		3.72	
Absorbed nominal capacity			Heating: 7°C outdoor / 30~35°C water (max) (1) kW		11.00 [15.20]		14.00 [16.70]		16.00 [17.80]	
			Cooling: 7°C outdoor / 30~35°C water (1) kW		7.20		9.50		10.50	
COP 7°C outdoor / 30~35°C water			5.00		4.71				4.57	
EER 35°C outdoor / 7~12°C water			3.30		3.22				2.82	
Nominal energy class 35°C			A+++		A++				A++	
Power supply			3N ~400 V 50 Hz							
Sound Power [2]			dB(A) 63		64		65			
Airflow			m3/h 4800		5400		6000			
Pipe diameter (Liquid - Gas)			inches 3/8 - 5/8							
Maximum length			m 75							
Maximum Height			30/20							
Operating ranges			°C (DB) 10~46 // -25~25 / -25~35							
Refrigerant fluid			R410							
Refrigerant charge			3.30 (60)		3.40 (60)					
(Maximum length of pipes without load)*			kg 3.30 (60)		3.40 (60)					
Compressor			Scroll DC Inverter							
200 L INDOOR UNIT PRICE										
260 L INDOOR UNIT PRICE										
260 L INDOOR SOLAR PANEL UNIT PRICE			For indoor unit with solar panel, contact us							
OUTDOOR UNIT PRICE										

\* Corresponds to the height of the unit with the minimum mounting foot height. This value can be adjusted up to +30 m.

\*\* 260 L tank compatible with models RWD-2.0-6.0NWSE that allow combination with solar panel.

†(1) The nominal power for cooling and heating is based on EN14511 and on the following conditions:

- Cooling: Entering water temperature 12°C and exiting water temperature 7°C; Outdoor temperature 35°C DB
- Heating: Input water temperature 30°C and output water temperature 35°C; Outdoor temperature 7°C DB, 6°C WB
- Pipe length 7.5 m; pipe Height 0 m†

(2) The sound level measurement is performed under the following conditions:

- Outdoor temperature: 7°C (DB) / 6°C (WB)
- Water entrance and exit temperature: 30/35°C

The sound level measurement is performed in an anechoic camera at 1 m from the frontal surface and at 1.5 m from the ground level

The sound pressure level is carried out in a reverberating chamber according to EN12102. The environmental conditions are those specified in standard EN 14511.

Guaranteed performance

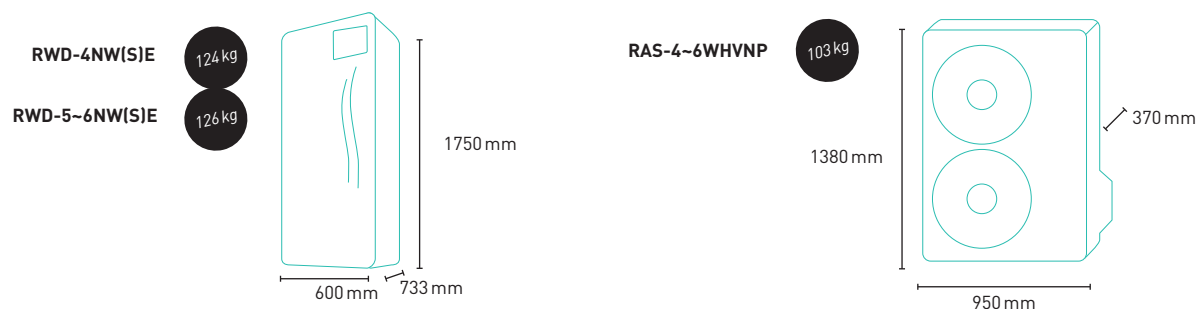
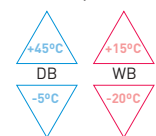

### STRUCTURE OF THE YUTAKI S COMBI

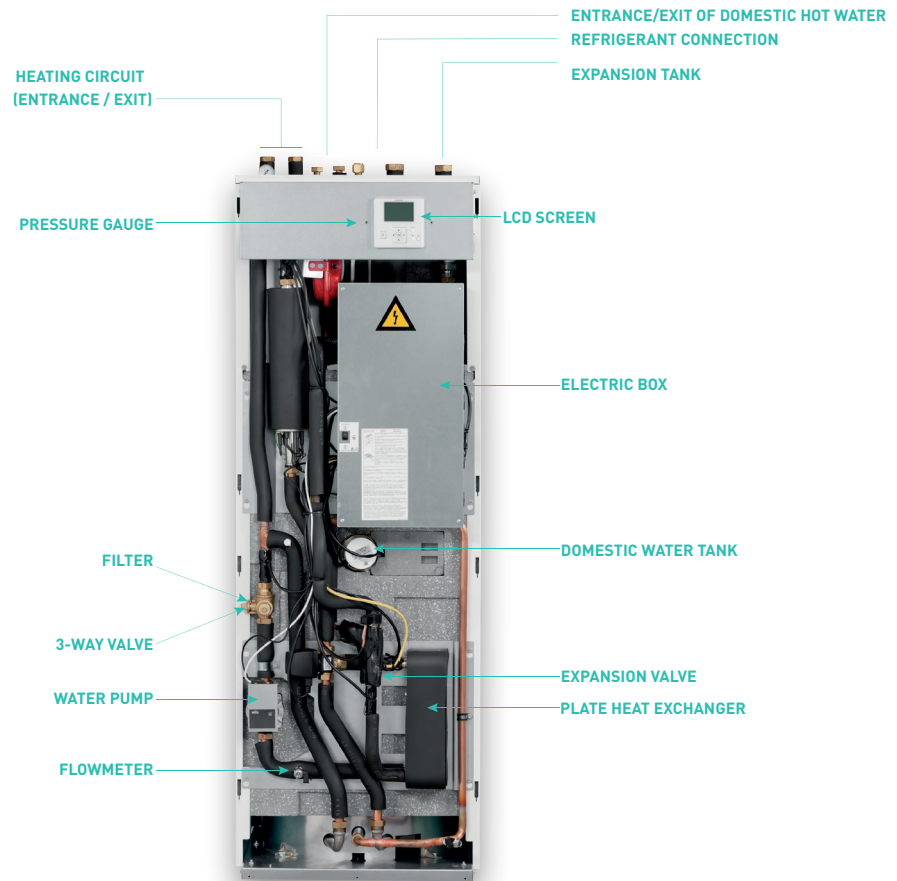
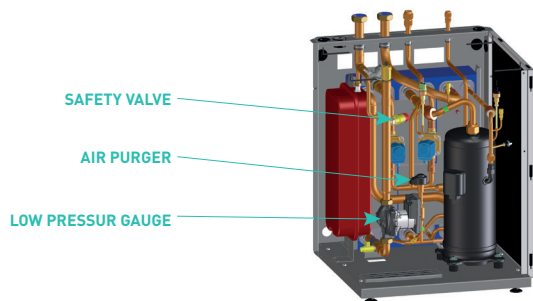

### SOLAR PANEL INSTALLATION

It connects the solar panel directly to the tank.

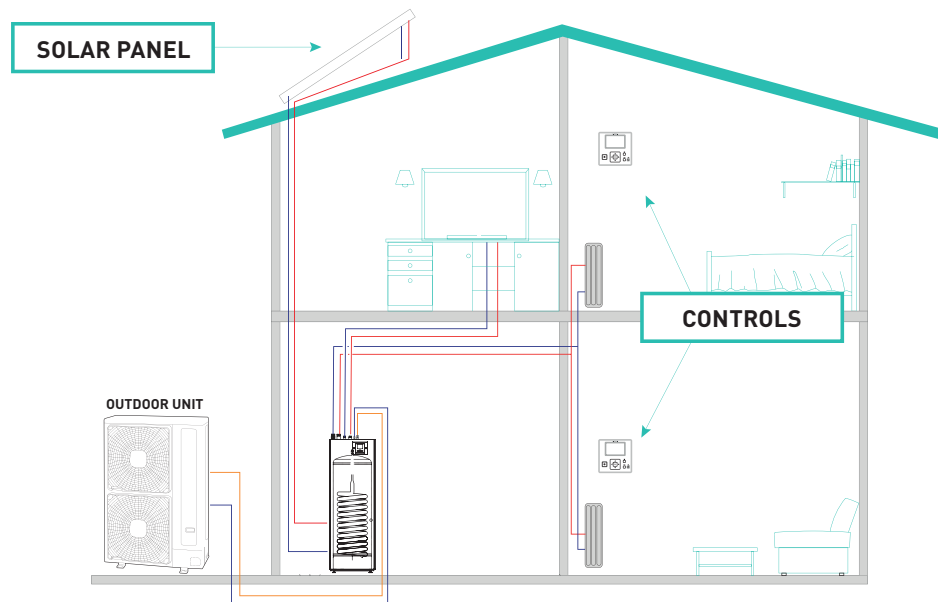

### HEATING/COOLING APPLICATION IN COMBINATION WITH SOLAR PANELS

The solar option is designed to transfer heat from the solar panels to the heat exchanger of the DHW tank and is installed in the system as shown.

In this option, the solar panels capture the sun's heat. When the temperature of the glycol solution in the solar panel is greater than that of the water in the DHW tank, the pump in the solar pump station and the solar kit start transferring the heat to the heat exchanger of the DHW tank.

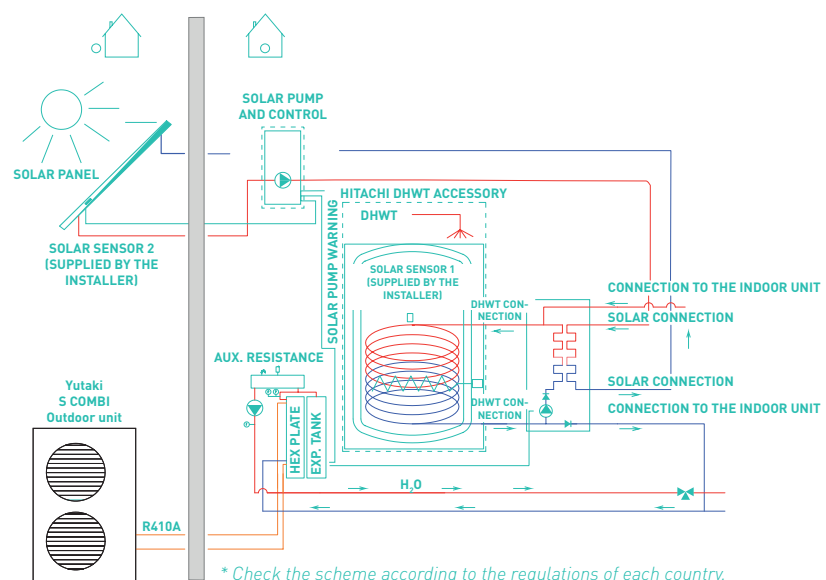



## HEATING AND DHW INVERTER AND HEATING AND DHW

### YUTAKI M RASM-3~6(V)NE

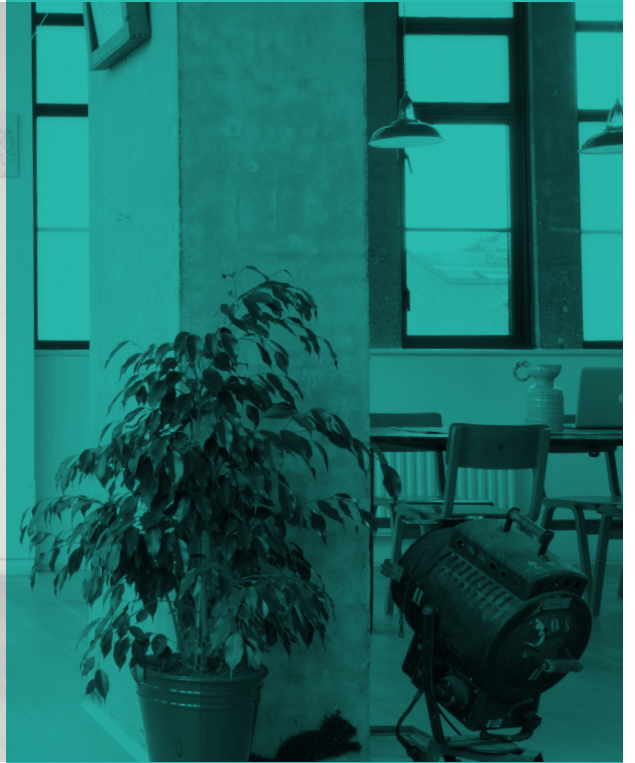

#### CHARACTERISTICS

##### Applications

Perfect for new construction and renovation with boiler replacement. Compatible with radiant floor heating, low and high temperature radiators and domestic hot water production.

##### Energy class A+++\*

##### 4 modes of operation

Comfort, savings, anti freeze and vacation.

##### Cooling kit

Reversible heat pump and temperature up to 60°C.

##### New technical components that improve performance

- Smaller electrical box without loss of efficiency
- Heat exchanger (PHEX)
- Water pump (before accessory)
- Water filter
- Closing valve
- Security valve
- Expansion valve

##### Wide operating ranges guaranteed

It ensures a comfortable heating temperature with minimum energy consumption, even in the most extreme conditions.

\*Depending on model.

## YUTAKI M

NAME OF THE SET		YUTAKI M 3HP	YUTAKI M 4HP	YUTAKI M 5HP	YUTAKI M 6HP	YUTAKI M 4HP	YUTAKI M 5HP	YUTAKI M 6HP	
		SINGLE PHASE				THREE-PHASE			
OUTDOOR UNIT		RASM-3VNE	RASM-4VNE	RASM-5VNE	RASM-6VNE	RASM-4NE	RASM-5NE	RASM-6NE	
Absorbed nominal power	Heating 7°C outdoor / 30-35°C water (1)	1.65	2.20	2.97	3.50	2.20	2.97	3.50	
	Cooling 7°C outdoor / 30-35°C water (1)	2.18	2.18	2.95	3.72	2.18	2.95	3.72	
Absorbed nominal capacity	Heating 7°C outdoor / 30-35°C water (max) (1)	7.50 [11.00]	11.00 [15.20]	14.00 [16.70]	16.00 [17.80]	11.00 [15.20]	14.00 [16.70]	16.00 [17.80]	
	Cooling 7°C outdoor / 30-35°C water (1)	6.00	7.20	9.50	10.50	7.20	9.50	10.50	
COP 7°C outdoor / 30-35°C water		4.55	5.00	4.71	4.57	5.00	4.71	4.57	
EER 35°C outdoor / 7-12°C water		2.75	3.30	3.22	2.82	3.30	3.22	2.82	
Nominal energy class 35°C		<b>A++</b>	<b>A+++</b>	<b>A+++</b>	<b>A++</b>	<b>A+++</b>	<b>A+++</b>	<b>A++</b>	
Power supply		1 ~230 V 50 Hz				3N ~400 V 50 Hz			
Sound Power (2)	dB(A)	64	64	65	67	64	65	67	
Airflow	m <sup>3</sup> /h	2682	4800	5400	6000	4800	5400	6000	
Heating Operating Range	Outdoor temperature °C (DB)	-25~25				-25~25			
	Water output temperature °C	20~55	20~60				20~60		
Cooling Operating Range	Outdoor temperature °C (DB)	10~46				10~46			
	Water output temperature °C	5~22				5~22			
Operating rank range (DHW)	Outdoor temperature °C (DB)	-25~35				-25~35			
	Water output temperature °C	30~75				30~75			
Refrigerant		R410a				R410a			
Refrigerant charge	kg	2.40	2.80	3.10		2.80	3.10		
Compressor		Scroll DC Inverter				Scroll DC Inverter			
OUTDOOR UNIT PRICE									
200 LITER DHWT WATER TANK PRICE									
300 LITER DHWT WATER TANK PRICE									

~(1) The nominal power for cooling and heating is based on EN14511 and on the following conditions:  
 - Cooling: Entering water temperature 12°C and exiting water temperature 7°C; Outdoor temperature 35°C DB  
 - Heating: Input water temperature 30°C and output water temperature 35°C; Outdoor temperature 7°C DB, 6°C WB  
 - Pipe length 7.5 m; pipe Height 0 m"

(2) The sound level measurement is performed under the following conditions:  
 -Outdoor temperature: 7°C (DB) / 6°C (WB)  
 -Water entrance and exit temperature: 30/35°C  
 -The sound level measurement is performed in an anechoic camera at 1 m from the frontal surface and at 1.5 m from the ground level  
 -The sound pressure level is carried out in a reverberating chamber according to EN12102. The environmental conditions are those specified in standard EN 14511.

Performance guaranteed

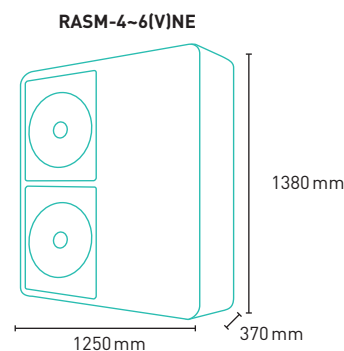
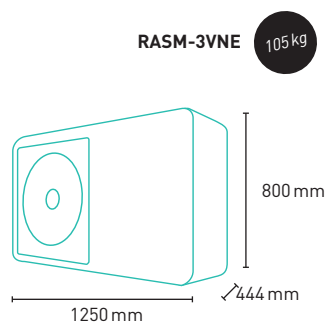

For more information about controls, see page 195.  
 Recommended prices - VAT not included, Waste Electrical and Electronic Equipment Directive (WEEE) fee not included.  
 To create the energy label visit our website [www.hitachiircon.es](http://www.hitachiircon.es) and use our Hitachi ErP Active Tool application.

## HEATING AND DHW

### SPLIT TYPE THERMODYNAMIC TANK

# YUTAMPO

## TAW-270NH2A

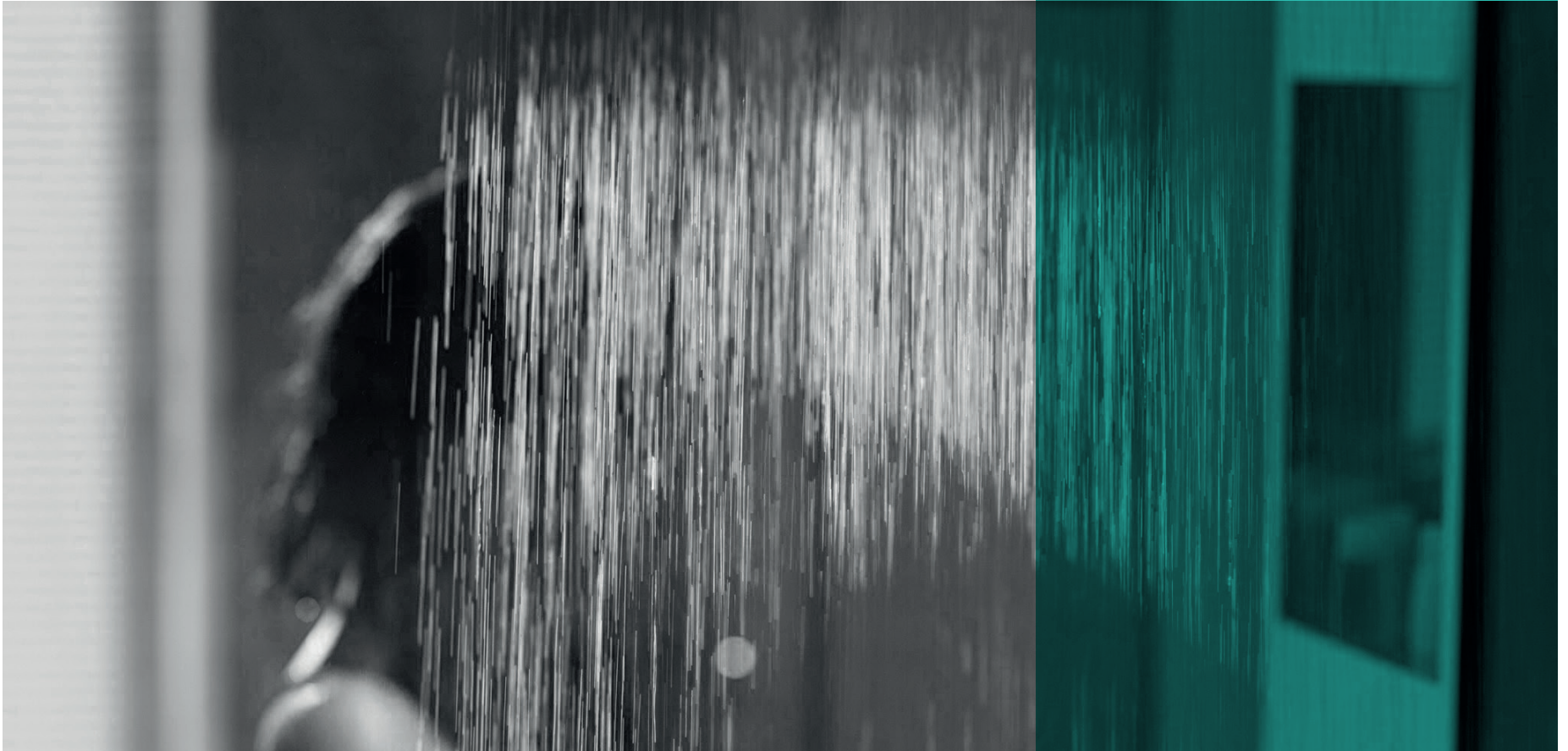

### CHARACTERISTICS

**Operation with outdoor air** For all seasons of the year (from +37°C ~ -15°C).

**More ecological**

Savings up to 70% on a traditional term.  
It does not directly emit CO<sub>2</sub> and intelligently manages operation with the weekly programmable clock.

**Double wall exchanger**

With anti-legionella function according to sanitary regulations.

**Production of domestic hot water**

**without increasing the heat indoors**

It absorbs the heat from the outdoor air and transfers it to the storage tank to heat the water up to 55°C with minimum energy consumption. Able to produce domestic hot water for a family of 4 to 6 people.

**Split System, maximum comfort**

No noise inside the house thanks to the double system. The outdoor unit withstands extreme environmental conditions as it is coated with Green Fin.



## YUTAMPO

NAME OF THE SET			YUTAMPO
<b>DHW WATER TANK</b>			<b>TAW-270NH2A</b>
Capacity	L		262
Material			Stainless steel
Electric resistance	W		2000
Pipe diameter	Liquid	inches	3/4
	Gas		1/4 - 3/8
<b>OUTDOOR UNIT</b>			<b>RAW-25NH2A</b>
COP (1)			3.09
Average heating capacity	W		2000
Sound pressure level (2)	dB(A)		46
Refrigerant			R410A
Power supply			230 V - 1 Ph - 50 Hz
Compressor			DC Twin Rotary
Type of regulation			DC Inverter
			<b>DOMESTIC HOT WATER PERFORMANCE</b>
Setpoint temperature only heat pump (with electrical resistance)	°C		55 (65)
Energy consumed in Standby mode	W		30
Maximum usable water volume	L		375
Heating time	h:min		06:20
<b>PRICE OF THE SET</b>			

(1) The technical data are based on standard EN16147, XL cycle. Ambient air temperature 7°C, hot water temperature 53.3°C.

(2) Sound pressure level is based on standard JIZ8731

Performance guaranteed

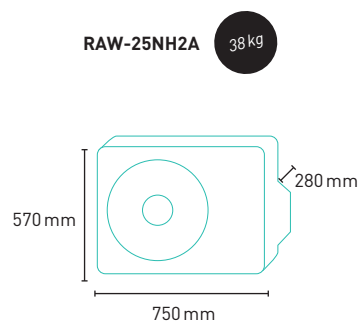
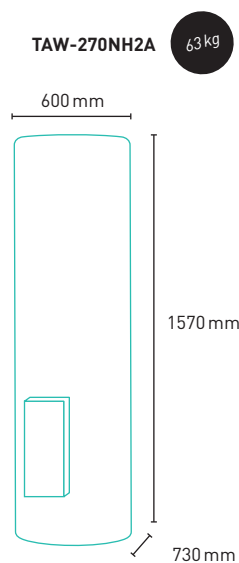

For more information about controls, see page 195.  
 Recommended prices - VAT not included, Waste Electrical and Electronic Equipment Directive (WEEE) fee not included.  
 To create the energy label visit our website [www.hitachiircon.es](http://www.hitachiircon.es) and use our Hitachi ErP AcTive Tool application.







# INDOOR UNITS







# INDOOR UNITS

<b>INDOOR UNITS</b>	<b>98</b>
CASSETTE TYPE	99
DUCT TYPE	103
WALL MOUNTED TYPE	107
FLOOR TYPE	109
CEILING TYPE	111
DX INTERFACE KIT	113

## INDOOR UNITS

## CASSETTE TYPE UNITS

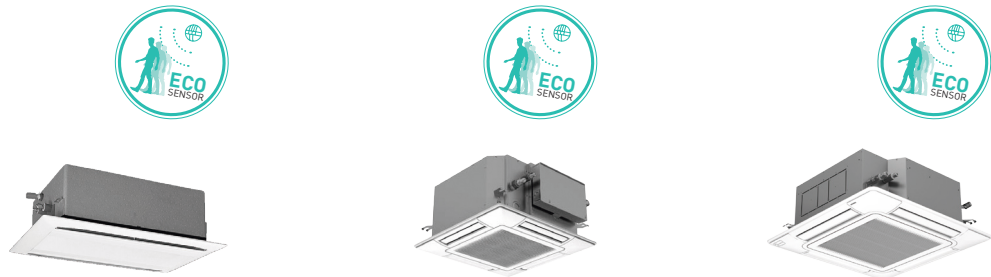

INDOOR UNIT	2-WAY CASSETTE	4-WAY 600 X 600 CASSETTE	4-WAY 800 X 800 PREMIUM CASSETTE
<b>CODE</b>	<b>RCD-(1-6)FSN3</b>	<b>RCIM-(0.6-2.5)FSN4E</b>	<b>RCI- 1-6 FSN4</b>
Presence sensor	YES	YES	YES
Slat/side axis control panel	YES/NO	YES/NO	YES/YES
Unit height	298 mm	285 mm	248 mm (1.0-2.5 HP) and 298 mm (3.0-6 HP)
<b>Electronic expansion valve</b>	<b>YES</b>	<b>YES</b>	<b>YES</b>
Drainage pump	YES	YES	YES
Adaptable to ceilings of up to	3.1 m	3.1 m	3.5 m (1.0-2.5 HP) and 4.2 m (3.0-6 HP)
Compatible with Utopia commercial range and VRF Set Free	YES	YES	YES

### RCIM-FSN4E PERFECT INSTALLATION BETWEEN 600 X 600 MM FALSE CEILINGS

Its measurements are perfect for installing in small spaces, where the height of the false ceiling and the width of the ceilings pose a requirement in choosing the cassette. The RCIM range adapts to these requirements without the need for removing any other false ceiling, **measuring only 285 mm high and 570 mm wide.**

Its **new compact panel**, allows its installation in narrow places as it can be placed between lighting fixtures in the modular ceiling. It fits in 600 x 600 mm panels leaving a margin of the same. It allows for the panel to be placed in narrow places, such as between lighting fixtures installed in the modular ceiling.

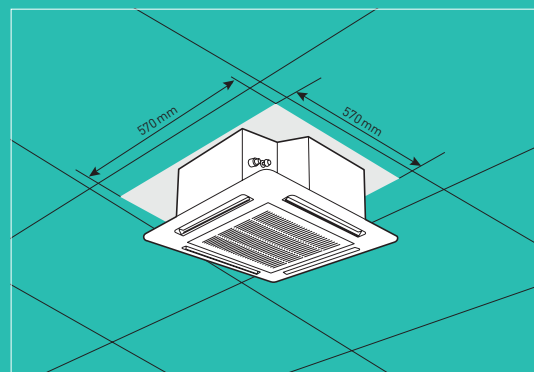
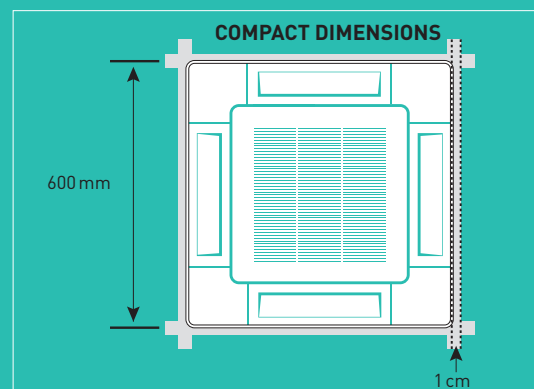



## PRESENCE SENSOR ENERGY CONSERVATION

The activity sensor allows the energy consumption to be adapted to the occupation of the room where it is installed. This maintains a comfortable indoor environment and reduces unnecessary consumption, generating significant energy savings.

**Adjusting the temperature by 1°C equals 7% savings.**

The presence sensor: Adjusts the temperature, volume and direction of the air flow according to occupancy. It also measures the activity of the room at constant intervals. When activating the sensor, there are three operating phases on the remote control with different operating conditions. The elapsed time between each phase is 1/3 of the time set in the control interval.

### EXAMPLE WITH A CONTROL INTERVAL OF 30 MIN

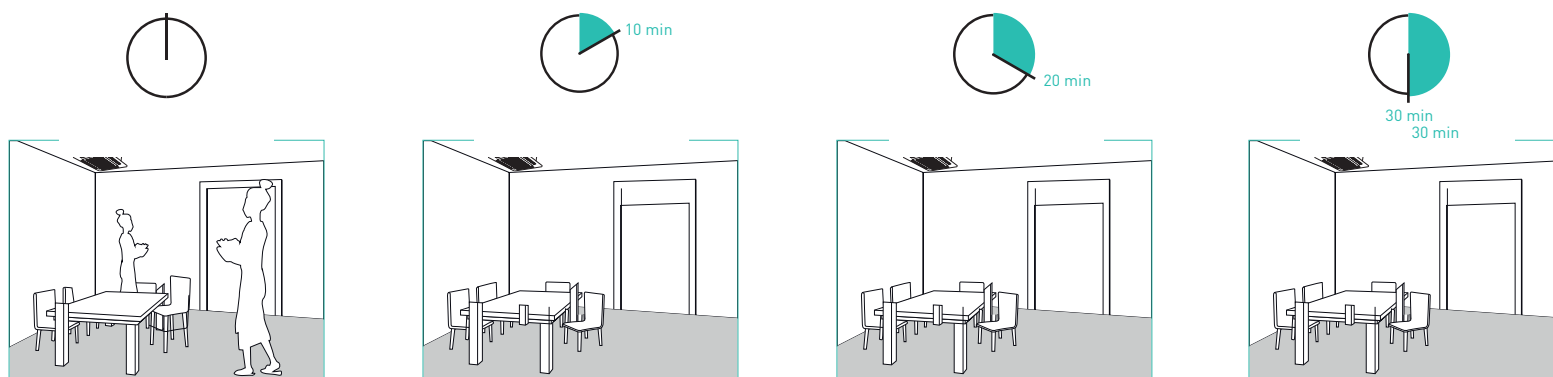

#### Phase A Activity

The cassette will operate with the setpoint temperature and selected fan speed.

#### Phase B 10 min without activity

Adjusting the temperature by 1°C. Volume of air -1 (minimum speed "low")

**7% ENERGY CONSERVATION**

#### Phase C 20 min without activity

Adjusting the temperature by 2°C, Air volume -2 minimum speed "low")

**14% ENERGY CONSERVATION**

#### Phase D 30 min without activity

**3 options:**  
 1. **"On" Mode**, keeps operation in Phase C.  
 2. **"Stand By" Mode**, the Indoor Unit enters "Thermo-off" and returns to normal operation when it detects activity.  
 3. **"Off" Mode** The Indoor Unit is turned off and on manually. (Contact Hitachi for more information)

## 4-WAY 600X600 CASSETTE



INDOOR UNIT		RCIM-0.6FSN4E	RCIM-0.8FSN4E	RCIM-1FSN4E	RCIM-1.5FSN4E	RCIM-2FSN4E	RCIM-2.5FSN4E
General information for adjustable Power	HP				● 1.30 ← 1.50	● 1.80 ← 2.00	● 2.30 ← 2.50
Nominal power <sup>(1)</sup> (UTOPIA)	Cooling	-	2.00	2.50	3.60	5.00	5.60
	Heating	-	2.20	2.80	4.00	5.60	6.30
Nominal power <sup>(1)</sup> (SET FREE)	Cooling	1.70	2.20	2.80	4.00	5.60	7.10
	Heating	1.90	2.50	3.20	4.80	6.30	8.50
Sound pressure level (low - medium - high) <sup>(2)</sup>	dB(A)	24.5 - 28 - 30 - 34	24.5 - 29 - 33 - 36	24.5 - 30 - 34 - 38	27.5 - 33 - 37 - 41	31 - 35 - 39 - 45	35 - 39 - 43 - 47
Sound power		47	50	51	54	56	60
Airflow (low - medium - high)	m3/h	360 - 450 - 510 - 600	360 - 480 - 570 - 660	360 - 510 - 600 - 720	420 - 570 - 660 - 780	480 - 600 - 720 - 900	600 - 720 - 840 - 960
power supply		230 V - 1 h - 50 Hz					
Pipe diameter (Liquid - Gas)	inches	1/4 - 1/2					
<b>INDOOR UNIT PRICE</b>							
<b>PANEL PRICE</b>							
<b>TOTAL PRICE</b>							

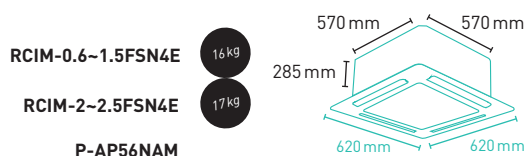



## 4-WAY 800X800 RCI PREMIUM CAS- SETTE

INDOOR UNIT		RCI - 1.0FSN4	RCI - 1.5FSN4	RCI - 2FSN4	RCI - 2.5FSN4	RCI - 3FSN4	RCI - 4FSN4	RCI - 5FSN4	RCI - 6FSN4
Adjustable power	HP		● 1.30 ← 1.50	● 1.80 ← 2.00	● 2.30 ← 2.50				
Nominal power <sup>(1)</sup> (UTOPIA)	Cooling	2.50	3.60	5.00	5.60	7.10	10.00	12.50	14.00
	Heating	2.80	4.00	5.60	6.30	8.00	11.20	14.00	16.00
Nominal power <sup>(1)</sup> (SET FREE)	Cooling	2.80	4.00	5.60	7.10	8.00	11.20	14.00	16.00
	Heating	3.20	4.80	6.30	8.50	9.00	12.50	16.00	18.00
Sound pressure level (low - medium - high) <sup>(2)</sup>	dB(A)	27 - 28 - 30 - 33	27 - 30 - 31 - 35	27 - 30 - 32 - 37	28 - 32 - 36 - 42	28 - 32 - 36 - 42	33 - 39 - 43 - 48	35 - 40 - 45 - 48	37 - 41 - 46 - 48
Sound power		52	53	55	56	57	64		68
Airflow (low - medium - high)	m3/h	540 - 660 - 780 - 900	660 - 840 - 1020 - 1260	660 - 840 - 1020 - 1320	840 - 1080 - 1380 - 1620	1200 - 1380 - 1560		1260 - 1560 - 1980 - 2220	1320 - 1680 - 2100 - 2220
Power supply		230 V - 1 Ph - 50 Hz							
Pipe diameter (Liquid - Gas)	inches	1/4 - 1/2		1/4 - 5/8		3/8 - 5/8			
<b>INDOOR UNIT PRICE</b>									
<b>P-AP160NA1 PANEL PRICE (WITHOUT SENSOR)</b>									
<b>P-AP160NAE ECO SENSOR OPTIONAL PANEL PRICE</b>									

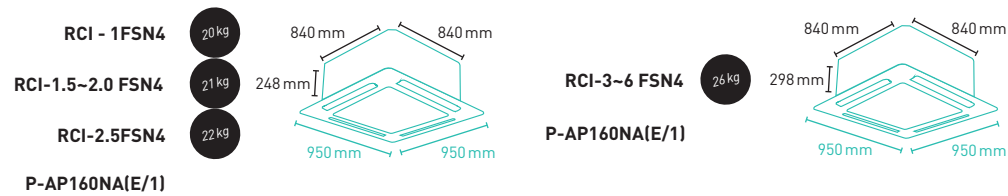



## 2-WAY CASSETTE

INDOOR UNIT		RCD-0,8FSN3	RCD-1FSN3	RCD-1.5FSN3	RCD-2FSN3	RCD-2.5FSN3	RCD-3FSN3	RCD-4FSN3	RCD-5FSN3	RCD-6FSN3
Adjustable power	HP		● 1.30 ← 1.50	● 1.80 ← 2.00	● 2.30 ← 2.50					
Nominal power <sup>(1)</sup> (UTOPIA)	Cooling	2.00	2.50	3.60	5.00	5.60	7.10	10.00	12.50	14.00
	Heating	2.20	2.80	4.00	5.60	6.30	8.00	11.20	14.00	16.00
Nominal power <sup>(1)</sup> (SET FREE)	Cooling	2.20	2.80	4.00	5.60	7.10	8.00	11.20	14.00	16.00
	Heating	2.50	3.20	4.80	6.30	8.50	9.00	12.50	16.00	18.00
Sound pressure level (low - medium - high) <sup>(2)</sup>	dB(A)	27 - 28 - 29 - 30	27 - 28 - 29 - 31	30 - 31 - 34 - 37	30 - 33 - 36 - 39	33 - 36 - 39 - 42	33 - 38 - 42 - 45	34 - 37 - 40 - 43	35 - 41 - 44 - 47	39 - 42 - 45 - 48
Sound power		44	46	49	51	52	55			59
Airflow (low - medium - high)	m3/h	6.5 - 7.5 - 9	7 - 8.5 - 9.5	10 - 11.5 - 13	10.5 - 12.5 - 14.5	12.5 - 14.5 - 16.5	12.5 - 16 - 18.5	20 - 23 - 26.5	21 - 27 - 31	24 - 28.5 - 32.5
Power supply		230 V - 1 h - 50 Hz								
Pipe diameter (Liquid - Gas)	inches	1/4 - 1/2				3/8 - 5/8				
<b>INDOOR UNIT PRICE</b>										
<b>PANEL PRICE</b>										
<b>TOTAL PRICE</b>										

Optional movement sensor SOR-NED

[1] The nominal power for cooling and heating is the combined power of the outdoor and indoor units of the system and are based on the EN14511 regulation with the following conditions:  
Cooling: indoor temperature 27°C DB, 19°C WB, outdoor temperature 35°C DB, -Heating: indoor temperature 20°C DB; outdoor temperature 7°C DB, 6°C WB. -Pipe length to 7.5m; height at 0m.  
[2] The sound level measurement is performed in an anechoic camera at 1.5 m below the unit.  
[3] The Cooling and Heating data for Nominal Heating Capacity (UTOPIA) refers to combinations of indoor units (0.8-10 HP) with UTOPIA series (IVX Premium, IVX, Comfort and ES). For combinations with indoor units of 2-10 HP, the nominal capacity refers to the combination 1 indoor unit.  
Recommended prices - VAT not included  
● Unit that can decrease its power using the DIP Switch.

**NOTE:**  
For Utopia Comfort, Utopia ES, Centrifugal VRF and Premium Utopia, use Nominal Power for Utopia.

RCD-0.8-1FSN3 23 kg  
RCD-1.5-3FSN3 25 kg  
P-AP90DNA

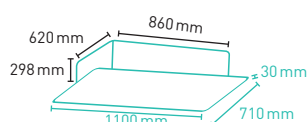

RCD-4-6FSN3 39 kg  
P-AP160DNA

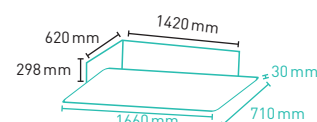



## INDOOR UNITS

# DUCT TYPE UNITS

QUICKLY CHOOSE THE UNIT THAT MOST CLOSELY MATCHES THE INSTALLATION REQUIREMENTS



INDOOR UNIT	MINI HOTEL DUCTS	LOW SILHOUETTE DUCTS	MEDIUM PRESSURE DUCTS	HIGH PRESSURE DUCTS	
CODE	RPIM-(0.6~1.5)FSN4E (-DU)	RPI-(0.6~1.5)FSN4E	RPI-(2~6)FSN4E	RPI-(8~10)FSN3E	RPI-(16~20)FSN3E
Unit height	275 mm	197 mm	275 mm	423 mm	846 mm
Electronic expansion valve	YES	YES	YES	YES	YES
Integrated condensate pump.	YES	YES	YES	NO	NO
Compatible with Utopia commercial range and VRF Set Free	YES	YES	YES	YES	NO

## LOW SILHOUETTE DUCTS

Easy installation in low-height false ceilings.

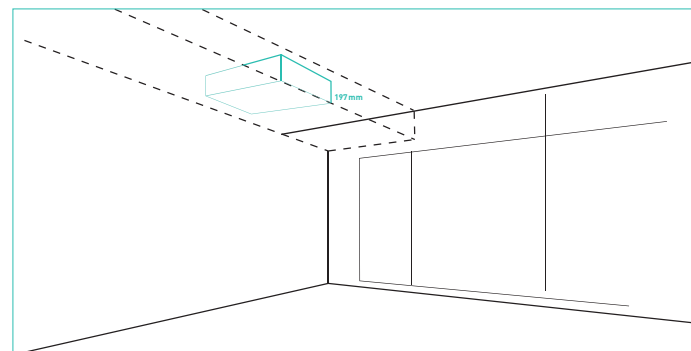

## CONDENSATE PUMP

It allows condensates to be elevated up to a height of 850 mm with regard to the unit. It is automatically activated when the water level is excessive.

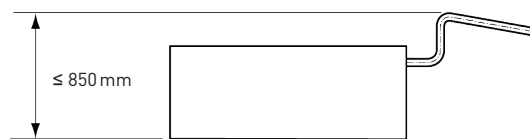

## MINI HOTEL DUCTS

By simply disassembling and swapping the unit's frontal panel, back panel and the electrical box, we can vary the position and direction of the entry of the air.

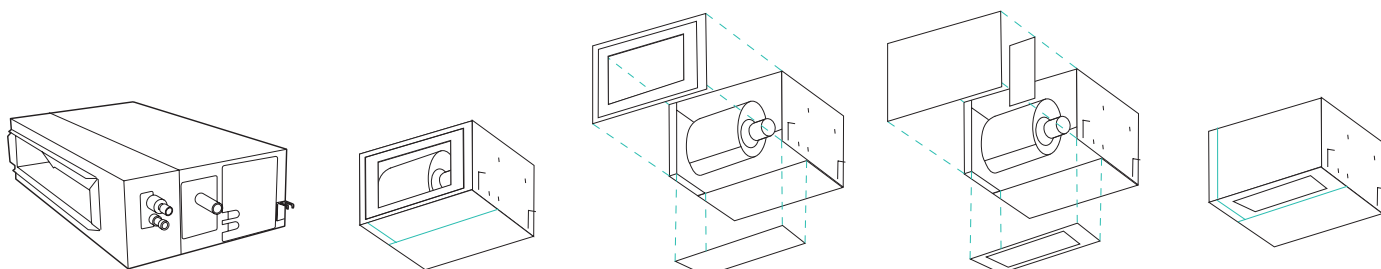

## HIGH PRESSURE DUCTS

Large capacity ducts for installations with higher requirements for cooling power and airflow.

Ideal for installation in large and open halls, supermarkets, restaurants and industrial warehouses.

The RPI-16~20FSN3 can be managed with a single remote and/or wired control.

No need to install UTA.

Boutique Gym by Martin Giacchetta, Madrid.  
VRF - Duct  
More info: [www.hitachiaircon.es](http://www.hitachiaircon.es)

### PRE-ASSEMBLED HOOKS (COMPACT UNIT)

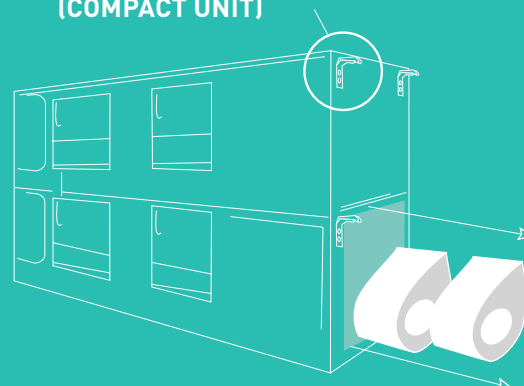

New lateral access for engine maintenance.

### AIR FILTER

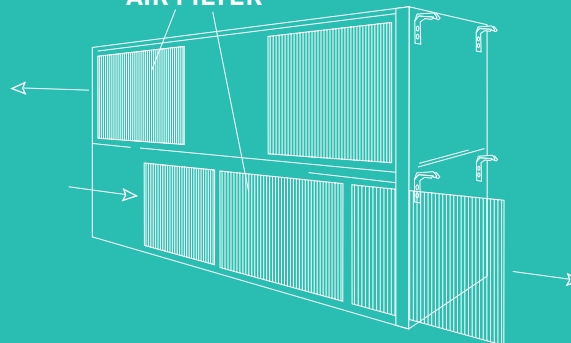

New air filter separated in three parts.  
(With access on both sides for maintenance)





## MINI HOTEL DUCTS

INDOOR UNIT		RPIM-0.6FSN4E	RPIM-0.8FSN4E	RPIM-1.FSN4E	RPIM-1.5FSN4E	RPIM-0.6FSN4E- DU*	RPIM-0.8FSN4E- DU*	RPIM-1.0FSN4E- DU*	RPIM-1.5FSN4E- DU*
Adjustable power	HP		● 0.60 ← 0.80		● 1.30 ← 1.50		● 0.60 ← 0.80		● 1.30 ← 1.50
Nominal power <sup>(1)</sup> (UTOPIA) <sup>(3)</sup>	Cooling		2.00	2.50	3.60		2.00	2.50	3.60
	Heating		2.20	2.80	4.00		2.20	2.80	4.00
Nominal power <sup>(1)</sup> (SET FREE)	Cooling	1.70	2.20	2.80	4.00	1.70	2.20	2.80	4.00
	Heating	1.90	2.50	3.20	4.80	1.90	2.50	3.20	4.80
Sound pressure level (low - medium - high) <sup>(2)</sup>	dB(A)	25 - 28 - 28	27 - 29 - 29		28 - 30 - 30	25 - 28 - 28	27 - 29 - 29		28 - 30 - 30
Sound power		49	50		51	49	50		51
Airflow (low - medium - high)	m <sup>3</sup> /h	330 - 372 - 420	330 - 408 - 480		480 - 540 - 600	330 - 372 - 420	330 - 408 - 480		480 - 540 - 600
Outdoor static pressure	Nom.	20	32		27	20	32		27
	(min-max)	[0-35]	[0-50]		[0-58]	[0-35]	[0-50]		[0-58]
Power supply		230 V - 1 Ph - 50 Hz							
Pipe diameter (Liquid - Gas)	inches	1/4 - 1/2							
PRICE									

\* Includes condensate pump  
Compatible with Airzone



## LOW SILHOUETTE DUCTS

INDOOR UNIT		RPI - 0.6FSN4E	RPI - 0.8FSN4E	RPI - 1.FSN4E	RPI - 1.5FSN4E
Adjustable power	HP		● 0.60 ← 0.80		● 1.30 ← 1.50
Nominal power <sup>(1)</sup> (UTOPIA) <sup>(3)</sup>	Cooling		2.00	2.50	3.60
	Heating		2.20	2.80	4.00
Nominal power <sup>(1)</sup> (SET FREE)	Cooling	1.70	2.20	2.80	4.00
	Heating	1.90	2.50	3.20	4.80
Sound pressure level (low - medium - high) <sup>(2)</sup>	dB(A)	27 - 30 - 32	29 - 31 - 33		29 - 31 - 34
Sound power		50	52		53
Airflow (low - medium - high)	m <sup>3</sup> /h	330 - 372 - 420	378 - 432 - 480		480 - 540 - 600
Outdoor static pressure	Nom.	20	32		27
	(min-max)	[0-30]	[0-50]		[0-50]
Power supply		230 V - 1 Ph - 50 Hz			
Pipe diameter (Liquid - Gas)	inches	1/4 - 1/2			
PRICE					

[1] The nominal power for cooling and heating is the combined power of the outdoor and indoor units of the system and are based on the EN14511 regulation with the following conditions: Cooling: indoor temperature 27°C DB, 19°C WB, outdoor temperature 35°C DB. -Heating: indoor temperature 20°C DB; outdoor temperature 7°C DB, 6°C WB. -Pipe length to 7.5m; height at 0m.

[2] The sound level measurement is performed in an anechoic camera at 1.5 m below the unit.

[3] The Cooling and Heating data for Nominal Heating Capacity (UTOPIA) refers to combinations of indoor units (0.8-10 HP) with UTOPIA series (IVX Premium, IVX, Comfort and ES). For combinations with indoor units of 2-10 HP, the nominal capacity refers to the combination 1 indoor unit.

Recommended prices - VAT not included

● Unit that can decrease its power using the DIP Switch.

### NOTE:

For Utopia Comfort, Utopia ES, Centrifugal VRF and Premium Utopia, use Nominal Power for Utopia.

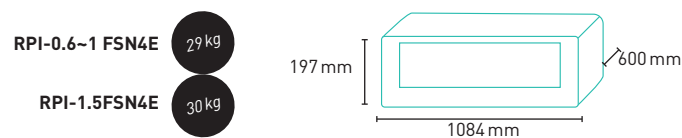





## MEDIUM PRESSURE DUCTS

INDOOR UNIT		RPI - 2.FSN4E	RPI - 2.5FSN4E	RPI - 3.FSN4E	RPI - 4.FSN4E	RPI - 5.FSN4E	RPI - 6.FSN4E
Adjustable power	HP	● 1.80 ← 2.00	● 2.30 ← 2.50	-	-	-	-
Nominal power <sup>(1)</sup> (UTOPIA)	Cooling	5.00	5.60	7.10	10.00	12.50	14.00
	Heating	5.60	6.30	8.00	11.20	14.00	16.00
Nominal power <sup>(1)</sup> (SET FREE)	Cooling	5.60	7.10	8.00	11.20	14.00	16.00
	Heating	6.30	8.50	9.00	12.50	16.00	18.00
Sound pressure level (low - medium - high) <sup>(2)</sup>	dB(A)	27 - 29 - 29	28 - 30 - 30	29 - 31 - 31	32 - 35 - 37	33 - 35 - 38	33 - 36 - 39
Sound power		55	56	57	62	65	66
Airflow (low - medium - high)	m3/h	600 - 750 - 960	780 - 960 - 1140	960 - 1140 - 1320	1500 - 1680 - 1800	1740 - 1920 - 2100	1800 - 1980 - 2160
Outdoor static pressure	Nom.	30	30		45	50	
	(min-max)	(0-120)	(0-125)		(0-120)	(0-140)	
Power supply		230 V - 1 Ph - 50 Hz					
Pipe diameter (Liquid - Gas)	inches	1/4 - 5/8			3/8 - 5/8		
<b>PRICE</b>							

\* Includes condensate pump  
Compatible with Airzone

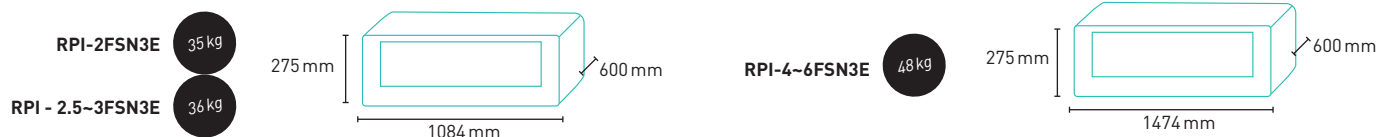

## HIGH PRESSURE DUCTS

INDOOR UNIT		RPI - 8.FSN3E	RPI - 10.FSN3E	RPI - 16.FSN3E	RPI - 20.FSN3E
Adjustable power	HP	-	-	-	-
Nominal power <sup>(1)</sup> (UTOPIA)	Cooling	20.00	25.00	-	-
	Heating	22.40	28.00	-	-
Nominal power <sup>(1)</sup> (SET FREE)	Cooling	22.40	28.00	45.00	56.00
	Heating	25.00	31.00	50.00	63.00
Sound pressure level (low - medium - high) <sup>(2)</sup>	dB(A)	51 - 54 - 54	52 - 55 - 55	51 - 54 - 54	52 - 55 - 55
Sound power		77	78	79	80
Airflow (low - medium - high)	High static pressure	3600 - 3960 - 3960	4110 - 4500 - 4500	7200 - 7920 - 7920	8220 - 9000 - 9000
	Low static pressure	3570 - 3960 - 3960	4056 - 4500 - 4500	7140 - 7920 - 7920	8100 - 9000 - 9000
Available static pressure (HSP)	Pa	180/220/220		180/220	
Available static pressure (LSP)		140/180/180		140/180	
Power supply		230 V - 1 Ph - 50 Hz			
Pipe diameter (Liquid - Gas)	inches	3/8 - 3/4	3/8 - 7/8	3/8 - 3/4	3/8 - 7/8
<b>PRICE</b>					

(1) The nominal power for cooling and heating is the combined power of the outdoor and indoor units of the system and are based on the EN14511 regulation with the following conditions:  
Cooling: indoor temperature 27°C DB, 19°C WB, outdoor temperature 35°C DB, -Heating: indoor temperature 20°C DB, outdoor temperature 7°C DB, 6°C WB. -Pipe length to 7.5m; height at 0m.  
(2) The sound level measurement is performed in an anechoic camera at 1.5 m below the unit.  
(3) The Cooling and Heating data for Nominal Heating Capacity (UTOPIA) refers to combinations of indoor units (0.8-10 HP) with UTOPIA series (IVX Premium, IVX, Comfort and ES). For combinations with indoor units of 2-10 HP, the nominal capacity refers to the combination 1 indoor unit.  
Recommended prices - VAT not included  
● Unit that can decrease its power using the DIP Switch.

**NOTE:**  
For Utopia Comfort, Utopia ES, Centrifugal VRF and Premium Utopia, use Nominal Power for Utopia.

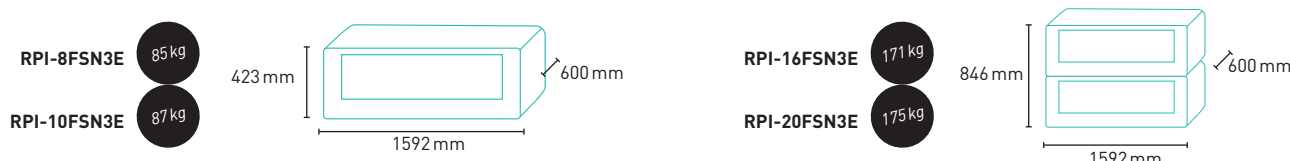

## INDOOR UNITS

## WALL MOUNTED UNITS

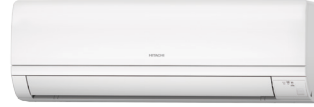

INDOOR UNIT	WALL MOUNTED WITH / WITHOUT VALVE	WALL MOUNTED WITH / WITHOUT VALVE	WALL MOUNTED WITH VALVE
Code	RPK-(0.6-1)FSN(H)3M	RPK-1.5FSN(H)3M	RPK-(2.0-4.0)FSN3M
Expansion valve	YES (RPK-(0.6-1)FSN3M)	YES (RPK-1.5FSN3M)	YES (RPK-(2.0-4.0)FSN3M)
	NO (RPK-(0.6-1)FSNH3M)	NO (RPK-1.5FSNH3M)	NO (RPK-(2.0-4.0)FSNH3M)
Compatible with Utopia commercial range and VRF Set Free	YES	YES	YES

## 4 SPEEDS OF AIR FLOW

The "HIGH H" speed covers the entire room, even rooms with high ceilings.

## CENTRALIZED CONTROL

No need for wired thermostats to connect to centralized Hitachi controllers.

Hotel Royal, Barcelona.  
VRF - Wall mounted.  
More info: [www.hitachiircon.es](http://www.hitachiircon.es)



## WALL-MOUNTED

INDOOR UNIT		RPK-0.6FSN3M	RPK-0.8FSN3M	RPK-1.FSN3M	RPK-1.5FSN3M	RPK-2.FSN3M	RPK-2.5FSN3M	RPK-3.FSN3M	RPK-4.FSN3M
Adjustable power	HP		● 0.60 ← 0.80		● 1.30 ← 1.50	● 1.80 ← 2.00	● 2.30 ← 2.50		
Nominal power <sup>(1)</sup> (UTOPIA)	Cooling		2.00	2.50	3.60	5.00	5.60	7.10	10.00
	Heating		2.20	2.80	4.00	5.60	6.30	8.00	11.20
Nominal power <sup>(1)</sup> (SET FREE)	Cooling	1.70	2.20	2.80	4.00	5.60	7.10	8.00	11.20
	Heating	1.90	2.50	3.20	4.80	6.30	8.50	9.00	12.50
Sound pressure level (low - medium - high) <sup>(2)</sup>	dB(A)	29 - 31 - 32 - 35	30 - 32 - 35 - 39	33 - 36 - 40 - 46	33 - 38 - 40 - 42	36 - 40 - 43 - 49		41 - 46 - 49 - 51	
Sound power		49	53	58	57	59		64	
Airflow (low - medium - high)	m3/h	360 - 420 - 450 - 480	390 - 420 - 480 - 600	450 - 540 - 660 - 840	600 - 780 - 840 - 900	720 - 840 - 1020 - 1140		900 - 1020 - 1140 - 1320	
Power supply		230 V - 1 Ph - 50 Hz							
Pipe diameter (Liquid - Gas)	inches	1/4 - 1/2			1/4 - 5/8		3/8 - 5/8		
PRICE									

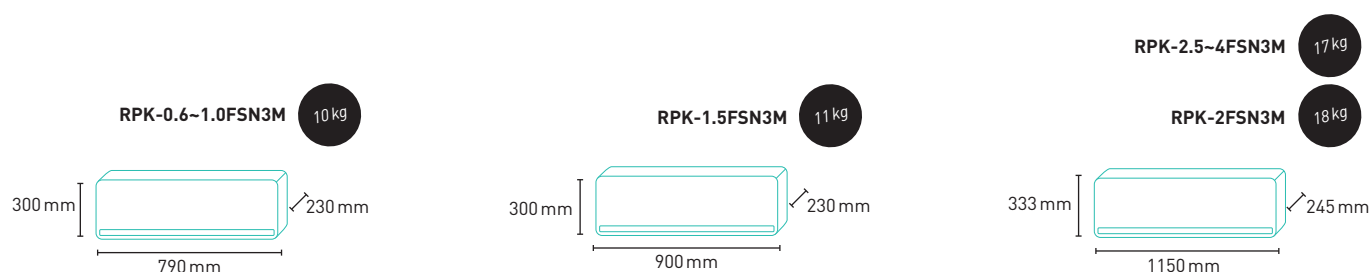

## WALL MOUNTED WITHOUT EXPANSION VALVE

INDOOR UNIT		RPK-0.6FSNH3M*	RPK-0.8FSNH3M*	RPK-1.FSNH3M*	RPK-1.5FSNH3M*
Adjustable power	HP		● 0.60 ← 0.80		● 1.30 ← 1.50
Nominal power <sup>(1)</sup> (UTOPIA)	Cooling		2.00	2.50	3.60
	Heating		2.20	2.80	4.00
Nominal power <sup>(1)</sup> (SET FREE)	Cooling	1.70	2.20	2.80	4.00
	Heating	1.90	2.50	3.20	4.80
Sound pressure level (low - medium - high) <sup>(2)</sup>	dB(A)	29 - 31 - 32 - 35	30 - 32 - 35 - 39	33 - 36 - 40 - 46	
Sound power		49	53	58	
Airflow (low - medium - high)	m3/h	360 - 420 - 450 - 480	390 - 420 - 480 - 600	450 - 540 - 660 - 840	
Power supply		230 V - 1 Ph - 50 Hz			
Pipe diameter (Liquid - Gas)	inches	1/4 - 1/2			
PRICE					

\* Without expansion valve  
Note: If the outdoor unit is centrifugal VRF, select the nominal power corresponding to the Utopia range.

(1) The nominal power for cooling and heating is the combined power of the outdoor and indoor units of the system and are based on the EN14511 regulation with the following conditions:  
Cooling: indoor temperature 27°C DB, 19°C WB, outdoor temperature 35°C DB. -Heating: indoor temperature 20°C DB; outdoor temperature 7°C DB, 6°C WB. -Pipe length to 7.5m; height at 0m.  
(2) The sound level measurement is performed in an anechoic camera at 1.5 m below the unit.  
(3) The Cooling and Heating data for Nominal Heating Capacity [UTOPIA] refers to combinations of indoor units [0.8-10 HP] with UTOPIA series [IVX Premium, IVX, Comfort and ES]. For combinations with indoor units of 2-10 HP, the nominal capacity refers to the combination 1 indoor unit.  
Recommended prices - VAT not included  
● Unit that can decrease its power using the DIP Switch.

**NOTE:**  
For Utopia Comfort, Utopia ES, Centrifugal VRF and Premium Utopia, use Nominal Power for Utopia.

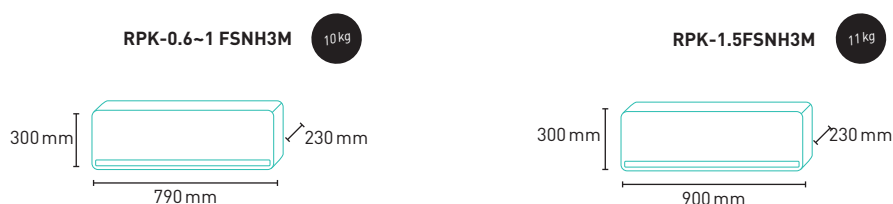



## INDOOR UNITS

## FLOOR TYPE UNITS



INDOOR UNIT	FLOOR TYPE WITHOUT CASING	FLOOR TYPE WITH CASING
CODE	RPF1-(1~2.5)FSN2E	RPF-(1~2.5)FSN2E
Unit height	620 mm	630 mm
Compatible with Utopia commercial range and-	YES	YES

## COMPACT DESIGN

With a depth of only 220 mm, RPF(I) units can be installed along the wall, occupying a minimum floor area. In addition, they allow for installation in limited spaces inside buildings.

## CONTROL IN THE ENCLOSURE

Remote control that can be integrated in the unit's enclosure, under the plastic cover.

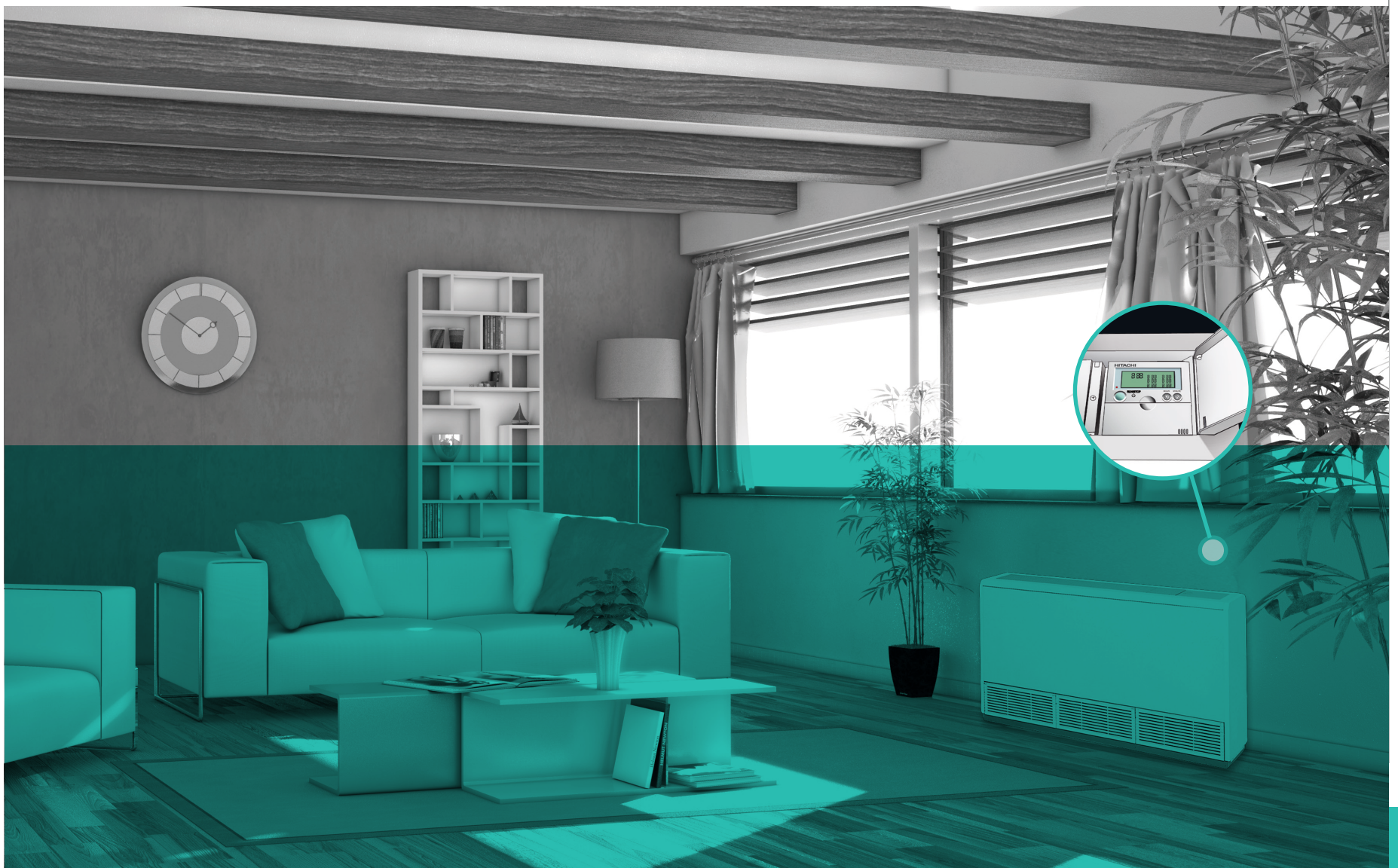

### FLOOR TYPE WITHOUT CASING

INDOOR UNIT		RPMI-1.FSN2E	RPMI-1.5FSN2E	RPMI-2.FSN2E	RPMI-2.5FSN2E
Adjustable power	HP		● 1.30 ← 1.50	● 1.80 ← 2.00	● 2.30 ← 2.50
Nominal power <sup>(1)</sup> (UTOPIA)	Cooling	2.50	3.60	5.00	5.60
	Heating	2.80	4.00	5.60	6.30
Nominal power <sup>(1)</sup> (SET FREE)	Cooling	2.80	4.00	5.60	7.10
	Heating	3.20	4.80	6.30	8.50
Sound pressure level (low - medium - high) <sup>(2)</sup>	dB(A)	29 - 32 - 35	31 - 35 - 38	32 - 36 - 39	34 - 38 - 42
Sound power		57	60		
Airflow (low - medium - high)	m3/h	360 - 420 - 510	540 - 600 - 720	660 - 840 - 960	
Power supply		230 V - 1 Ph - 50 Hz			
Pipe diameter (Liquid - Gas)	inches	1/4 - 1/2		1/4 - 5/8	3/8 - 5/8
<b>PRICE</b>					

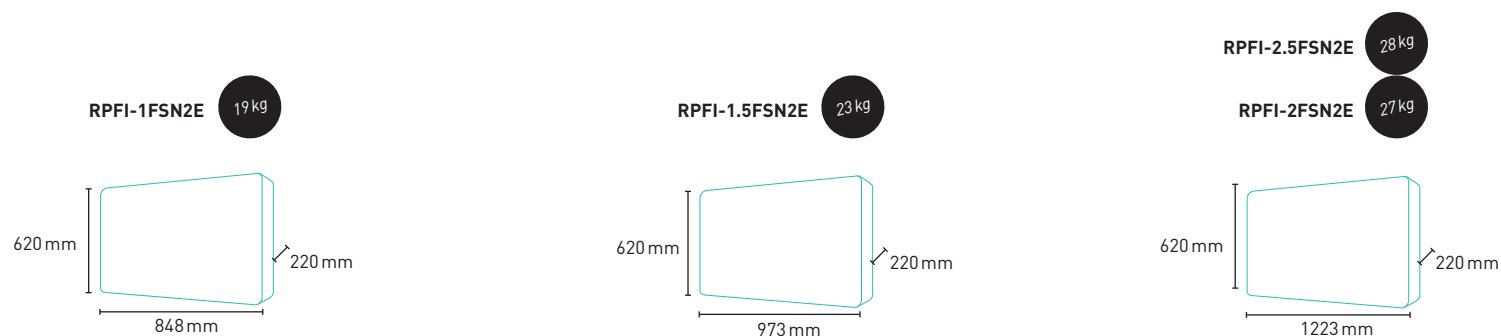

### FLOOR TYPE WITH CASING

INDOOR UNIT		RPF-1.FSN2E	RPF-1.5FSN2E	RPF-2.FSN2E	RPF-2.5FSN2E
Adjustable power	HP		● 1.30 ← 1.50	● 1.80 ← 2.00	● 2.30 ← 2.50
Nominal power <sup>(1)</sup> (UTOPIA VRF CENTRIFUGE)	Cooling	2.50	3.60	5.00	5.60
	Heating	2.80	4.00	5.60	6.30
Nominal power <sup>(1)</sup> (SET FREE)	Cooling	2.80	4.00	5.60	7.10
	Heating	3.20	4.80	6.30	8.50
Sound pressure level (low - medium - high) <sup>(2)</sup>	dB(A)	29 - 32 - 35	31 - 35 - 38	32 - 36 - 39	34 - 38 - 42
Sound power		57	60		
Airflow (low - medium - high)	m3/h	360 - 420 - 510	540 - 600 - 720	660 - 840 - 960	
Power supply		230 V - 1 Ph - 50 Hz			
Pipe diameter (Liquid - Gas)	inches	1/4 - 1/2		1/4 - 5/8	3/8 - 5/8
<b>PRICE</b>					

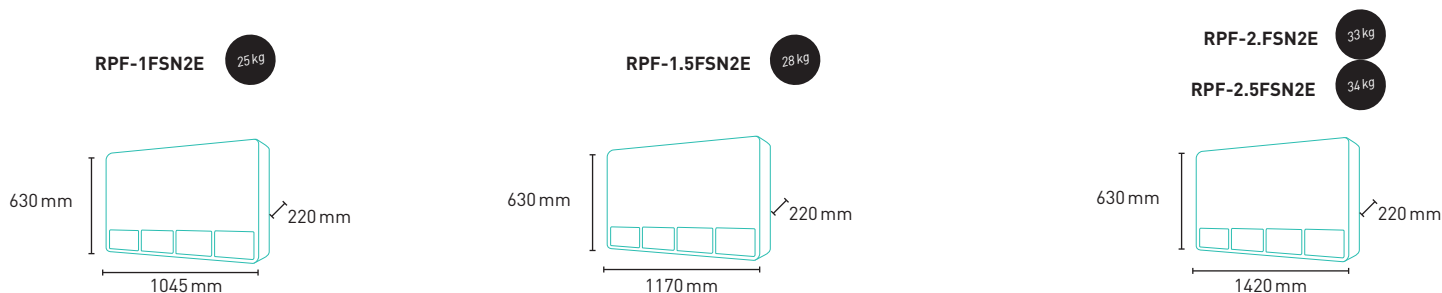

(1) The nominal power for cooling and heating is the combined power of the outdoor and indoor units of the system and are based on the EN14511 regulation with the following conditions: Cooling: indoor temperature 27°C DB, 19°C WB, outdoor temperature 35°C DB. -Heating: indoor temperature 20°C DB; outdoor temperature 7°C DB, 6°C WB. -Pipe length to 7.5m; height at 0m.  
 (2) The sound level measurement is performed in an anechoic camera at 1.5 m below the unit.  
 (3) The Cooling and Heating data for Nominal Heating Capacity (UTOPIA) refers to combinations of indoor units (0.8-10 HP) with UTOPIA series (IVX Premium, IVX, Comfort and ES). For combinations with indoor units of 2-10 HP, the nominal capacity refers to the combination 1 indoor unit.  
 Recommended prices - VAT not included  
 ● Unit that can decrease its power using the DIP Switch.

**NOTE:**  
 For Utopia Comfort, Utopia ES, Centrifugal VRF and Premium Utopia, use Nominal Power for Utopia.

**INDOOR UNITS**

**CEILING TYPE UNITS**



INDOOR UNIT	CEILING WITHOUT SENSOR	CEILING WITH SENSOR
CODE	RPC-(3~6)FSN3E	RPC-(1.5~6)FSN3E
Movement Sensor	NO	YES
Compatible with Utopia commercial range and VRF Set Free	YES	YES

**OPTIMIZED DEFLECTOR**

The deflector achieves better air distribution throughout the room, so the thermal sensation of the people in the room will be homogeneous, both for anyone near the indoor unit and those who are farther from it.

**AUTOMATIC DEFLECTOR**



WHILE IT IS STOPPED



DOWNWARD AIR FLOW



HORIZONTAL AIR FLOW

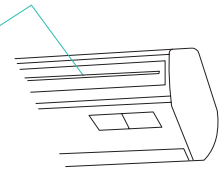

**4 AIR FLOW SPEEDS**

The "HIGH H" speed covers the whole room, even rooms with high ceilings, so you do not need to adjust the speed with the remote control.

**ENERGY CONSERVATION WITH THE PRESENCE SENSOR**

The activity sensor model RPC-(1.5~6)FSN3 adjusts its operation depending on the activity in the room. This way if the unit is installed in a room where the people's activity is intermittent, it automatically stops working if there is no one in it, without needing to turn the indoor unit off.





CEILING

INDOOR UNIT		RPC-3.FSN3E	RPC-4.FSN3E	RPC-5.FSN3E	RPC-6.FSN3E
Adjustable power	HP				
Nominal power <sup>(1)</sup> (UTOPIA)	Cooling	7.10	10.00	12.50	14.00
	Heating	8.00	11.20	14.00	16.00
Nominal power <sup>(1)</sup> (SET FREE)	Cooling	8.00	11.20	14.00	16.00
	Heating	9.00	12.50	16.00	18.00
Sound pressure level (low - medium - high) <sup>(2)</sup>	dB(A)	39 - 45 - 49		41 - 46 - 49	44 - 48 - 50
Sound power		65			66
Airflow (low - medium - high)	m <sup>3</sup> /h	960 - 1260 - 1620	1140 - 1440 - 1800	1260 - 1680 - 2100	1620 - 1920 - 2220
Power supply		230 V - 1 Ph - 50 Hz			
Pipe diameter (Liquid - Gas)	inches	3/8 - 5/8			
<b>PRICE</b>					

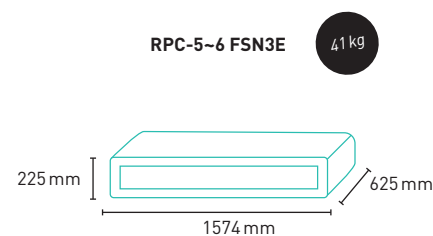
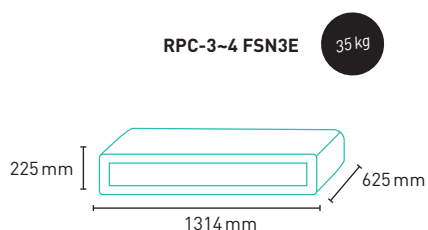

CEILING WITH MOVEMENT SENSOR



INDOOR UNIT		RPC-1.5FSN3	RPC-2.0FSN3	RPC-2.5FSN3	RPC-3.0FSN3	RPC-4.0FSN3	RPC-5.0FSN3	RPC-6.0FSN3
Adjustable power	HP	● 1.30 ← 1.50	● 1.80 ← 2.00	● 2.30 ← 2.50				
Nominal power <sup>(1)</sup> (UTOPIA)	Cooling	3.60	5.00	5.60	7.10	10.00	12.50	14.00
	Heating	4.00	5.60	6.30	8.00	11.20	14.00	16.00
Nominal power <sup>(1)</sup> (SET FREE)	Cooling	4.00	5.60	7.10	8.00	11.20	14.00	16.00
	Heating	4.80	6.30	8.50	9.00	12.50	16.00	18.00
Sound pressure level (low - medium - high) <sup>(2)</sup>	dB(A)	28 - 31 - 35 - 37	28 - 31 - 35 - 38		29 - 33 - 37 - 40	32 - 37 - 42 - 44	35 - 41 - 46 - 49	36 - 42 - 47 - 49
Sound power		53	54		56	60	64	65
Airflow (low - medium - high)	m <sup>3</sup> /h	540 - 660 - 780 - 900	540 - 660 - 780 - 900	690 - 840 - 990 - 1140	750 - 930 - 1110 - 1260	1020 - 1320 - 1590 - 1800	1200 - 1530 - 1860 - 2100	1260 - 1620 - 1950 - 2220
Power supply		230 V - 1 Ph - 50 Hz						
Pipe diameter (Liquid - Gas)	inches	1/4 - 1/2	1/4 - 5/8		3/8 - 5/8			
<b>PRICE</b>								

(1) The nominal power for cooling and heating is the combined power of the outdoor and indoor units of the system and are based on the EN14511 regulation with the following conditions: Cooling: indoor temperature 27°C DB, 19°C WB, outdoor temperature 35°C DB. -Heating: indoor temperature 20°C DB; outdoor temperature 7°C DB, 6°C WB. -Pipe length to 7.5m; height at 0m.  
 (2) The sound level measurement is performed in an anechoic camera at 1.5 m below the unit.  
 (3) The Cooling and Heating data for Nominal Heating Capacity [UTOPIA] refers to combinations of indoor units (0.8-10 HP) with UTOPIA series (IVX Premium, IVX, Comfort and ES). For combinations with indoor units of 2-10 HP, the nominal capacity refers to the combination 1 indoor unit.  
 Recommended prices - VAT not included  
 ● Unit that can decrease its power using the DIP Switch.

**NOTE:**  
 For Utopia Comfort, Utopia ES, Centrifugal VRF and Premium Utopia, use Nominal Power for Utopia.

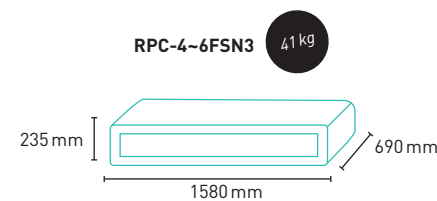
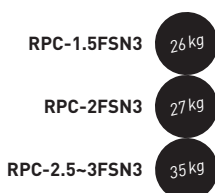
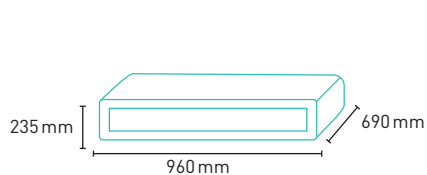

## INDOOR UNITS

## DX INTERFACE KIT

**ENERGY CONSERVATION AND IMPROVED THERMAL SENSATION IN COMMERCIAL INSTALLATIONS WITH VERY HIGH FOOT TRAFFIC.**

**IT SIMPLIFIES THE INSTALLATION OF THIRD-PARTY AIR CONDITIONERS, WITHOUT THE NEED TO INSTALL CHILLERS WITH HYDRAULIC LINES.**

The **DX-KIT interface** is the device used to connect the UTAs' direct expansion batteries, air curtains and high flow duct units with Hitachi outdoor units, to work in heating and cooling mode.

With the possibility of regulating the power depending on the temperature of the input and/or output of the battery, or with an external analog signal depending on the cooling/heating needs.

Its integration allows air curtains with direct expansion valves to also work in cooling, unlike conventional electric air curtains that only operate in heating mode.

In operation with air conditioners, the DX-KIT tempers the air as per the thermal requirements.

The kit includes: expansion valve, temperature probes and the necessary electronic regulation devices. Compatible with the Commercial range and VRF Set Free Systems.

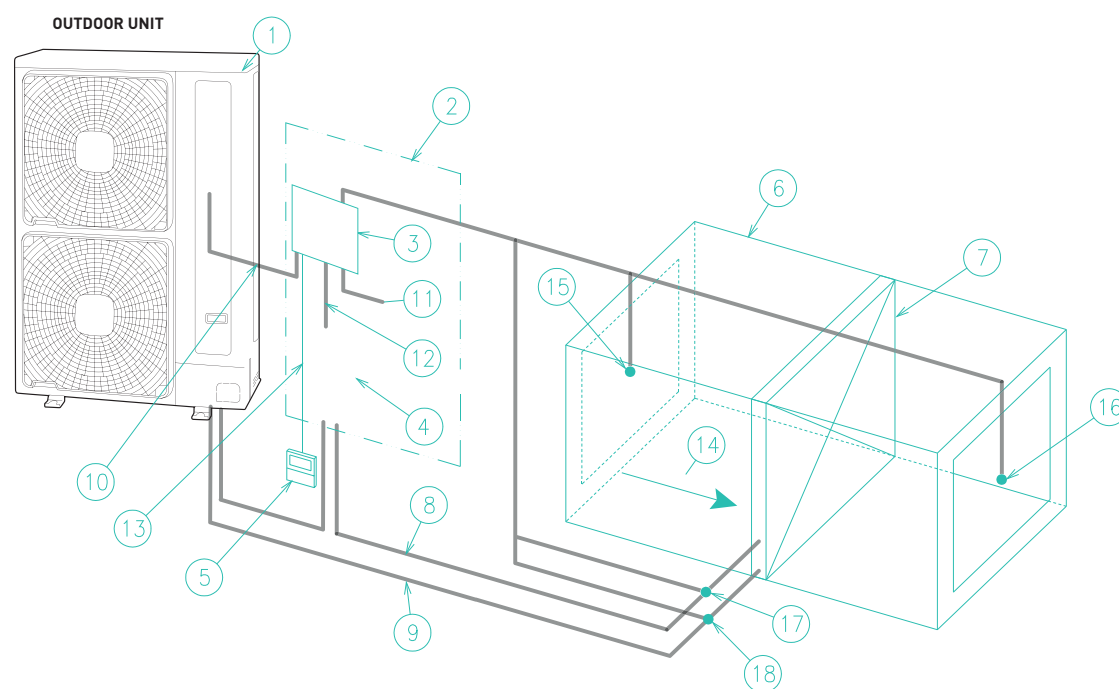

1	Hitachi RAS-H(V)RN(M/S)(1/2)E Outdoor Unit
2	DX EXV-(2.0-10.0)E Interface
3	Control box
4	Expansion valve box
5	Remote control (PC-ART)
6	Unit or device with heat exchange
7	DX heat exchanger
8	Liquid pipes
9	Gas pipes
10	Outdoor-indoor communication
11	Power supply
12	Expansion Valve Control Communication
13	Remote control communication
14	Air flow direction
15	Input thermistor
16	Input thermistor
17	Liquid pipe thermistor
18	Gas pipe thermistor



**DX-KIT**

DX KIT MODEL			EXV-2.0E2	EXV-2.5E2	EXV-3.0E2	EXV-4.0E2	EXV-5.0E2	EXV-6.0E2	EXV-8.0E2	EXV-10.0E2
Allowed capacity	Cooling	kW	4.0 - 5.0 - 5.6	4.8 - 6.0 - 6.3	5.7 - 7.1 - 8.0	8.0 - 10.0 - 11.2	10.0 - 12.5 - 14.0	11.2 - 14.0 - 16.0	16.0 - 20.0 - 22.4	20.0 - 25.0 - 28.0
	Heating		4.5 - 5.6 - 7.1	5.6 - 7.0 - 7.1	6.4 - 8.0 - 9.0	9.0 - 11.2 - 12.5	11.2 - 14.0 - 16.0	12.8 - 16.0 - 18.0	17.9 - 22.4 - 25.0	22.4 - 28.0 - 31.5
Exchanger volume	Minimum	L	0.57	0.89	1.03	1.51	1.92	1.92	2.92	3.89
	Maximum		1.64	1.83	2.89	4.56	4.56	5.11	6.93	10.73
Dimensions	High	mm	291	291	291	291	291	291	291	291
	Width		341	341	341	341	341	341	341	341
	Depth		127	127	127	127	127	127	127	127
Weight		kg	3.0	3.0	3.0	3.0	3.0	3.0	3.0	3.0
Power supply			1~230 V 50 Hz	1~230 V 50 Hz	1~230 V 50 Hz	1~230 V 50 Hz	1~230 V 50 Hz	1~230 V 50 Hz	1~230 V 50 Hz	1~230 V 50 Hz
<b>EXPANSION VALVE BOX</b>										
Dimensions	High	mm	431	431	431	431	431	431	431	431
	Width		199	199	199	199	199	199	199	199
	Depth		103	103	103	103	103	103	103	103
Weight		kg	2.7	2.7	2.7	2.7	2.7	2.7	4.5	4.5
Pipe connection		mm	6.35	9.52	9.52	9.52	9.52	9.52	9.52	9.52
Remote control			PC-ARFPE	PC-ARFPE	PC-ARFPE	PC-ARFPE	PC-ARFPE	PC-ARFPE	PC-ARFPE	PC-ARFPE

Maximum exchanger volume: only allowed with specific UTOPIA DX outdoor units. Contact us for more details.

**CONTACT US FOR INFORMATION ABOUT PRICES.**

**COMBINABILITY ACCORDING TO THE TYPE OF APPLICATION**

		Outdoor unit according to system considered		
		Utopia ES and IVX	Utopia DXw RAS-[XH(V)]NP1E	Set Free
Air curtain	Combinability	1 x 1	-	Multi*
	Controlled variable	Temperature of driven air	-	Temperature of return air
	Capacity	2~10 HP	-	2~10 HP
Ducts	Combinability	1 x 1	Modular	Multi*
	Controlled variable	Temperature of return air	Temperature of return air	Return temperature
	Capacity	2~10 HP	12~50 HP	2~10 HP
UTA	Combinability	-	Single/Modular	-
	Controlled variable	-	Temperature of driven air	-
	Capacity	-	4~50 HP	-

\* The allowed connectivity ratio for the Set Free system changes according to the power of the connected DX KIT. Contact us for more information.

Sephora, Granada.  
Indoor Units





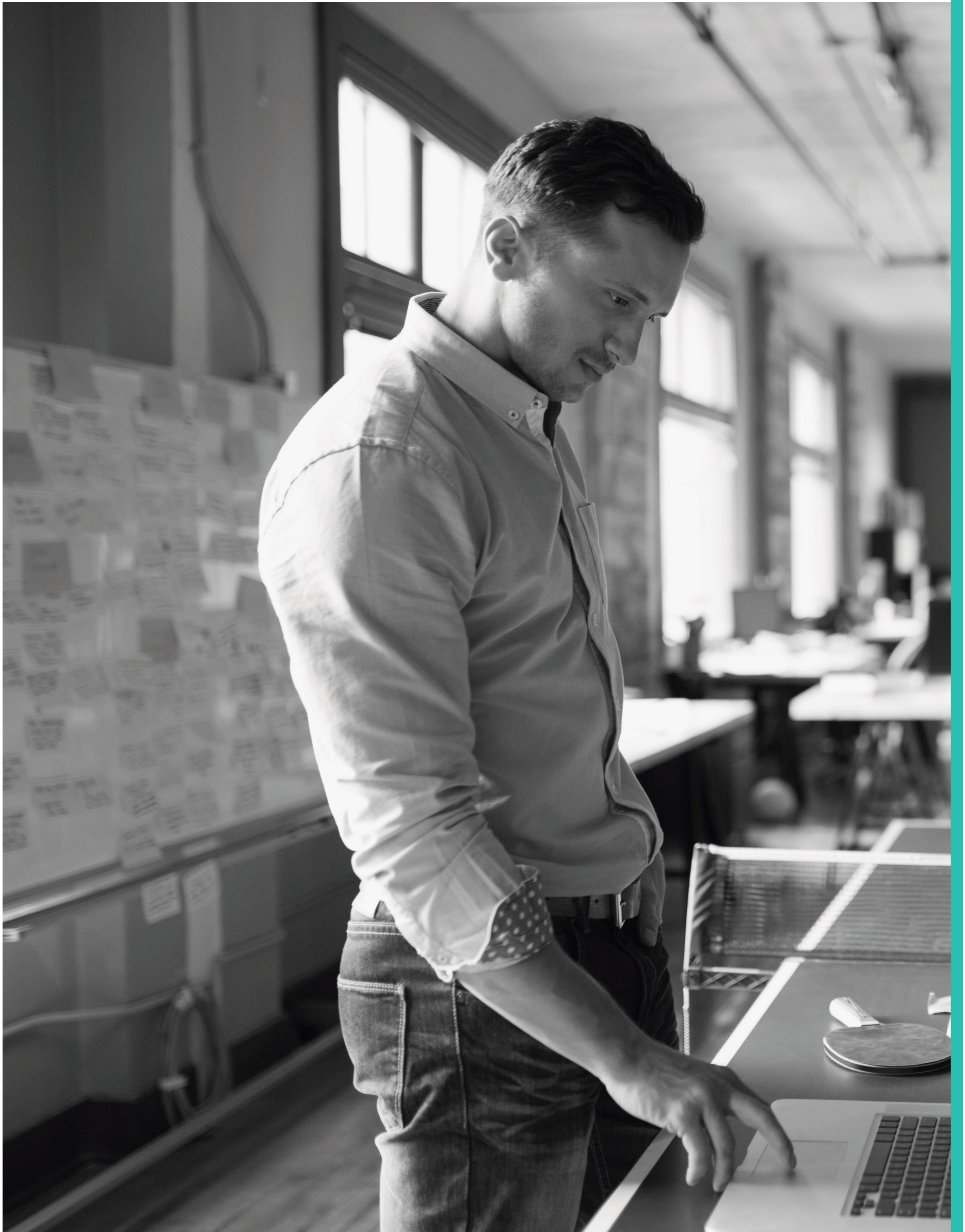



# COM MER CIAL

COMMERCIAL



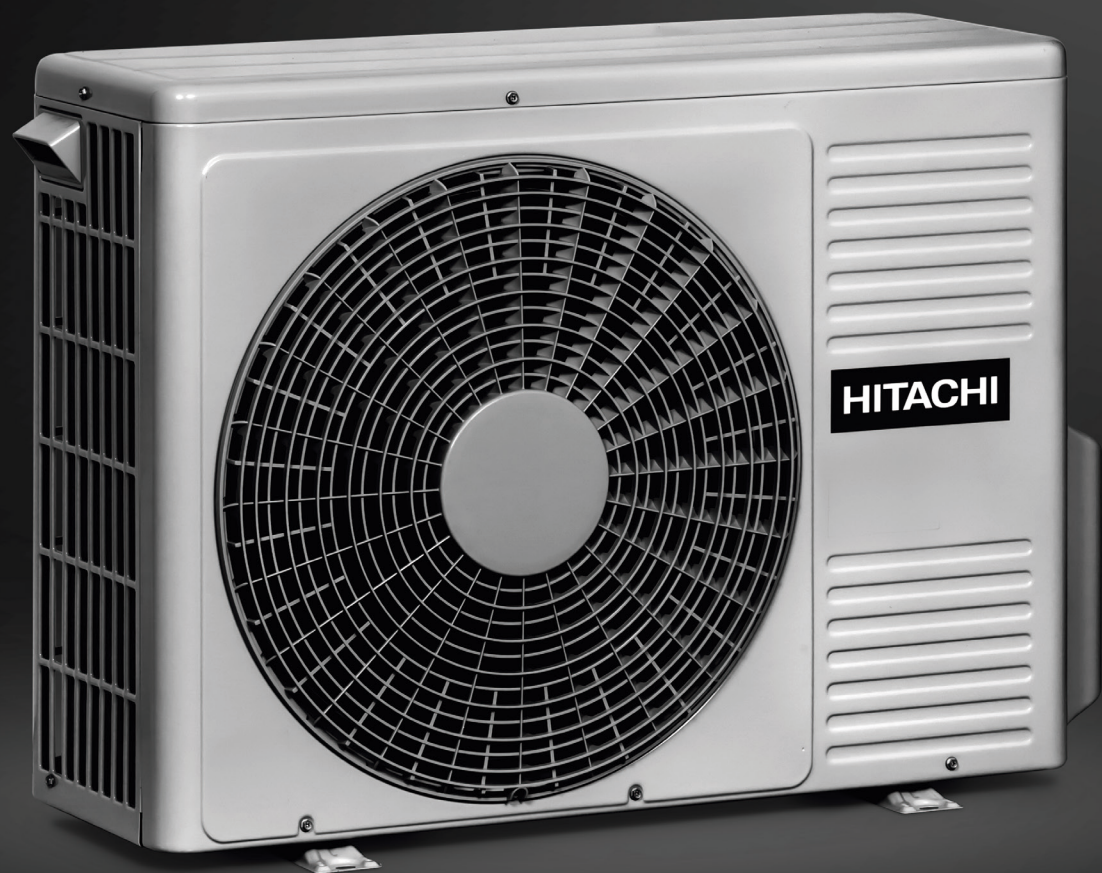



# COMMERCIAL



<b>COMMERCIAL</b>	<b>118</b>
UTOPIA IX COMFORT	121
ENERGY CLASS	123
MONO COMBINATIONS	124
COMBINATIONS	125
UTOPIA ES	130
ENERGY CLASS	133
MONO COMBINATIONS	134
MULTICOMBINATIONS	135

# UTOPIA IVX COMFORT

With the precision of a VRF

**Ideal solution for light commercial applications**

**Easy to install**, because it is a flexible, compact and lightweight solution, it reduces installation time by half.

**High seasonal performance** even at partial loads. Capacity index between 90% and 115%.

**Compatible** with all Hitachi centralized control and management systems.

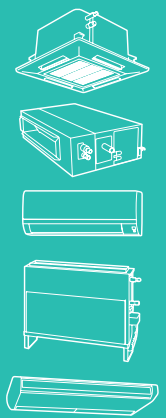

More information about compatible indoor units

▶ Page 98



More information about compatible controls and accessories

▶ Page 192

- Cools up to 4 different spaces
- Independent control
- Different setpoint temperatures
- Different fan speeds
- Different work schedules (with a programmable control)

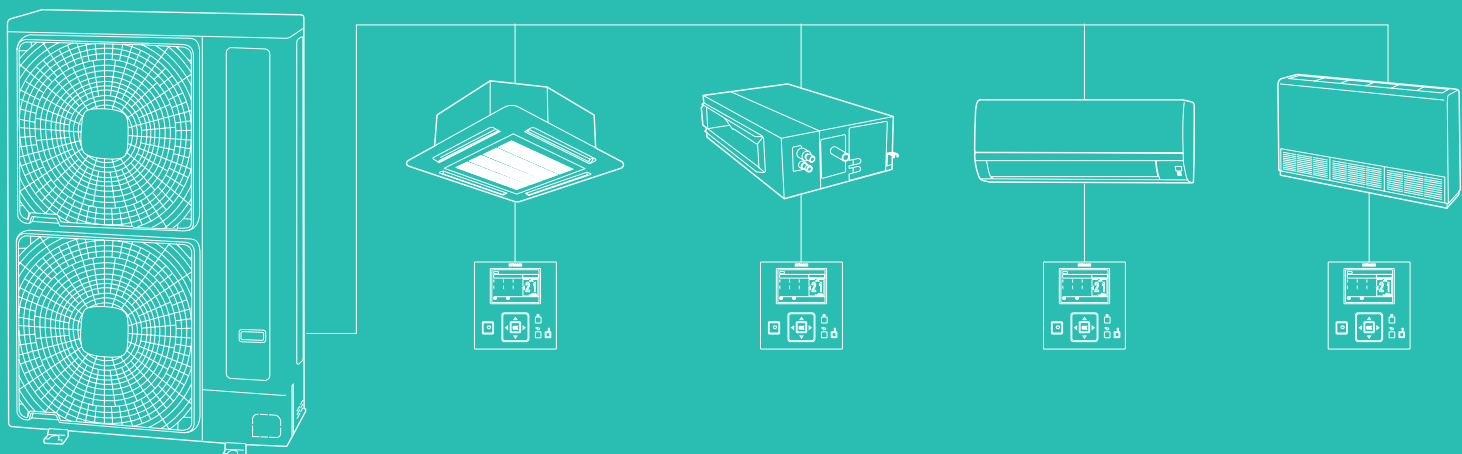



AIR CONDITIONING FOR  
**4 DIFFERENT SPACES**  
WITH **INDEPENDENT CONTROL**



MAXIMUM ACTUAL  
**COLD DISTANCE UP TO 100 M (125 M EQUIVALENT)**



UP TO  
**6 HP** WITH  
A SINGLE  
FAN

COMPLIES WITH EUROPEAN  
REGULATIONS **LOT.11 AND**  
**THE ERP TIER 2 DIRECTIVE**



## OUTDOOR UNIT INVERTER

# UTOPIA IVX COMFORT

RAS - 3 ~ 6H(V)NC1E

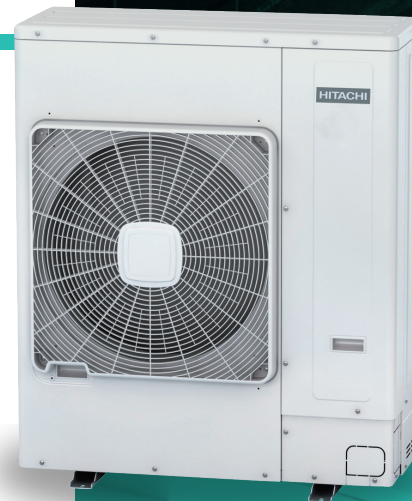

## CHARACTERISTICS

### UTOPIA IVX COMFORT in HITACHI's simplified alternative to VRF

It is the perfect choice for air conditioning small and medium businesses, with highly demanding requirements.

### High performance

Maximum seasonal performance at partial loads, which generates energy conservation.

### Flexibility

Compatible with System Free indoor units that are managed through all individual or centralized control systems, with H - Link II option.

### Optional DX-KIT

Intended for the integration of air curtains and air treatment units when required.

### Operation at extreme temperatures

The best performance even at extreme temperatures,  $-20^{\circ}\text{C}$  in heating and at  $46^{\circ}\text{C}$  in cooling.

### DC Inverter Compressor

Increased performance at low speed thanks to the transmission mechanism and refinement of the engine.

### Air conditioning of 4 spaces

Air condition up to 4 different and independent spaces, each indoor unit with its own control.

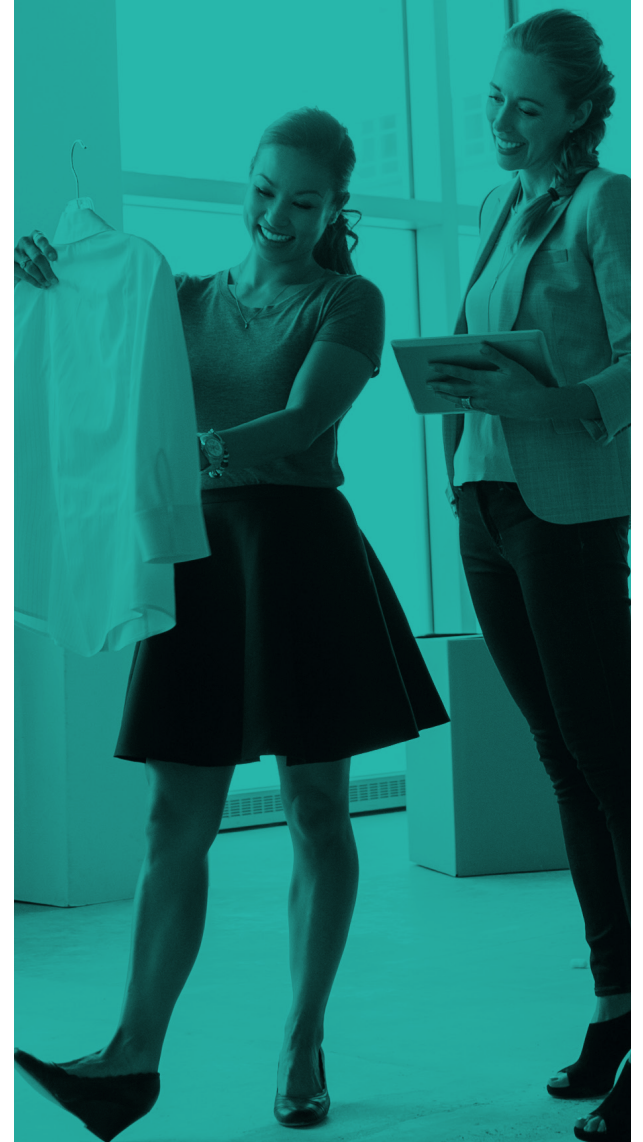
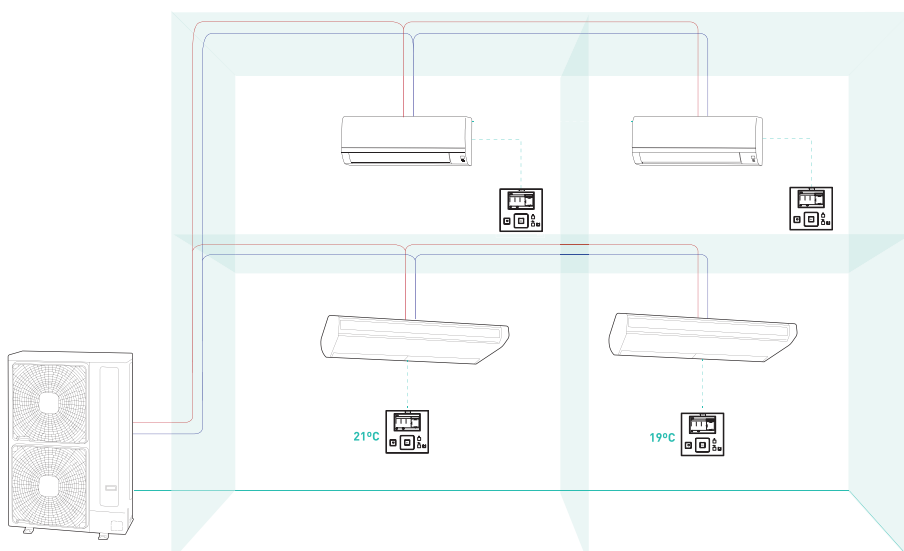

## UTOPIA IVX COMFORT

### UTOPIA IVX COMFORT SINGLE PHASE

OUTDOOR UNITS		RAS-3HVNC1	RAS-4HVNC1E	RAS-5HVNC1E	RAS-6HVNC1E
Number of connected units (min-max)		MONO-TWIN		MONO-TWIN-TRI-QUADRI	
Nominal power <sup>(1)</sup>	Cooling	7.10 (3.20-8.00)	10.00 (4.50-11.20)	12.50 (5.70-14.00)	14.00 (6.00-16.00)
	Heating kW	8.00 (3.50-10.60)	11.20 (5.00-14.00)	14.00 (5.00-18.00)	16.00 (5.00-20.00)
Absorbed nominal power	Cooling	2.14	2.55	3.54	4.12
	Heating	1.88	2.30	3.43	4.32
EER - COP <sup>(2)</sup>		More information on page 123		3.37 - 3.89 (A/A)	3.26 - 3.56 (A/B)
Sound pressure level (night mode) <sup>(3)</sup>		48 (46)	52 (50)	52 (50)	55 (53)
Airflow in heat		2682	3720	4080	4800
Power supply		1-230 V 50 H			
Pipe diameter (Liq - Gas)		inches 3/8 - 5/8			
Maximum length		50	70	75	75
Maximum height		30/20			
Initial refrigerant charge (maximum length of pipes)		1.9 (20)	3.2 (30)		
Additional refrigerant charge		40	40	60	
Refrigerant		R410A			
Compressor		SCROLL DC INVERTER			
PRICE					

### UTOPIA IVX COMFORT THREE-PHASE

OUTDOOR UNITS		RAS-4HNC1E	RAS-5HNC1E	RAS-6HNC1E	RAS-8HNC	RAS-10HNC	RAS-12HNC
Possible Combinations		MONO - TWIN - TRI - QUADRI					
Nominal power (1)	Cooling	10.00 (4.50-11.20)	12.50 (5.70-14.00)	14.00 (6.00-16.00)	20.00 (8.00-22.40)	25.00 (10.00-28.00)	30.00 (11.20-33.50)
	Heating kW	11.20 (5.00-14.00)	14.00 (5.00-18.00)	16.00 (5.00-20.00)	22.40 (6.30-28.00)	28.00 (8.00-35.00)	33.50 (9.00-37.50)
Absorbed nominal power	Cooling	2.55	3.54	4.12	5.69	8.02	11.05
	Heating	2.30	3.43	4.32	5.62	7.45	8.96
EER - COP <sup>(2)</sup>		More info on page 123	3.37 - 3.89 (A/A)	3.26 - 3.56 (A/B)	3.36 - 3.81 (A/A)	3.02 - 3.63 (B/A)	2.57 - 3.54 (E/B)
Sound pressure level (night mode) (3)		52 (50)	52 (50)	55 (53)	57 (55)	58 (56)	59 (56)
Airflow in heat		3720	4080	4800	7620	8040	9780
Power supply		3N-400 V 50 Hz					
Pipe diameter (Liq - Gas)		inches 3/8 - 5/8			3/8 - 1	1/2 - 1	
Maximum length		70	75		100		
Maximum height		30/20					
Initial refrigerant charge (maximum length of pipes)		kg(m) 3.2 (30)			5.7 (30)	6.2 (30)	6.7 (30)
Additional refrigerant charge		40	60	60	it must be calculated		
Refrigerant		R410A					
Compressor		SCROLL DC INVERTER					
PRICE							

(1) The nominal cooling and heating capacity is the combined capacity of the RAS system and is based on EN14511

- Cooling: Indoor temperature 27°C DB; outdoor temperature 35°C DB.  
- Heating: Indoor temperature 20°C DB; outdoor temperature 7°C WB, 6°C WB. Pipe length: 7.5 m

(2) SEER and SCOP conform to the EN 14825 regulation.

The SEER, SCOP, EER and COP are specified on the outdoor unit in combination with the indoor unit mentioned. COP and EER data are specified for RCI-FSN4 indoor unit combination.

(3) The sound pressure level has been measured in an anechoic camera at 1.5m from ground level and 1m from the front of the unit (Units operating at their nominal supply voltage).

Guaranteed performance



RAS - 3HVNC1 44 kg

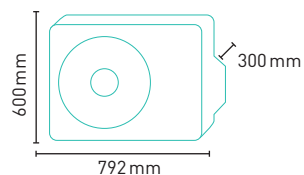

RAS - 4H(V)NC1E 79 kg

RAS-5-6H(V)NC1E 89 kg

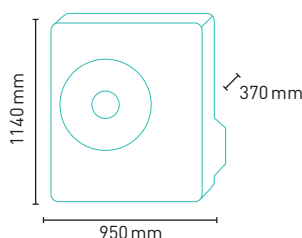

RAS - 8HNC 136 kg

RAS - 10HNC 138 kg

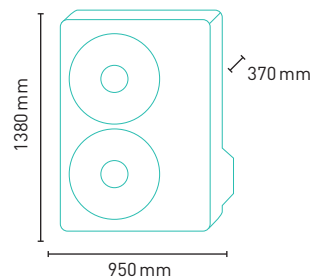

RAS - 12HNC 168 kg

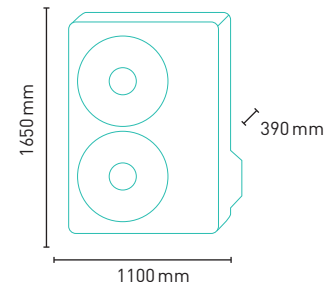

For more information about controls, see page 199.

Recommended prices - VAT not included, Waste Electrical and Electronic Equipment Directive (WEEE) fee not included.

To create the energy label visit our website [www.hitachiircon.es](http://www.hitachiircon.es) and use our Hitachi ErP AcTive Tool application.

## ENERGY CLASS

### OUTDOOR UNIT INVERTER

# UTOPIA IVX COMFORT

RAS - 3 ~ 6H(V)NC1E

## STANDARD CAPACITIES IN COOLING AND HEATING

Since January 1, 2015, the European Union's Eco-design ErP regulations affect air conditioning units of less than 12 kW (ErP.Tier 2 Directive). Therefore, the SEER and SCOP seasonal yields must be shown in these units, which provide a more accurate estimate of the actual performance of the product during the period in use.

COMBINATIONS		COOLING			HEATING		
OUTDOOR UNIT	INDOOR UNIT	SEER	ENERGY CLASS	P DESIGN (35°C)	SCOP	ENERGY CLASS	P DESIGN (-10°C)
				KW			KW
RAS-3HVNC1	RCI-3,0FSN4	6.00	A +	7.10	4.21	A +	5.60
	RPC-3,0FSN3	5.29	A	7.10	4.13	A +	5.60
	RPC-3,0FSN3E	4.68	B	7.10	3.80	A	5.60
	RPI-3,0FSN4E	4.97	B	7.10	3.80	A	5.60
	RPK-3,0FSN3M	5.35	A	7.10	3.80	A	5.60
RAS-4HVNC1E	RCI-4.0FSN4	6.57	A ++	10.00	4.47	A +	8.70
	RPC-4.0FSN3	5.02	B	10.00	3.90	A	8.70
	RPC-4.0FSN3E	4.61	B	10.00	3.80	A	7.40
	RPI-4.0FSN4E	5.38	A	10.00	4.01	A +	8.70
	RPK-4.0FSN3M	5.56	A	10.00	3.83	A	7.40
RAS-4HNC1E	RCI-4.0FSN4	6.41	A ++	10.00	4.47	A +	8.70
	RPC-4.0FSN3	4.93	B	10.00	3.9	A	8.70
	RPC-4.0FSN3E	4.53	C	10.00	3.8	A	7.40
	RPI-4.0FSN4E	5.27	A	10.00	4.01	A +	8.70
	RPK-4.0FSN3M	5.45	A	10.00	3.83	A	7.40





# MONO COMBINATIONS

These examples of mono combinations have been calculated with the PC-ARF PE control (not standard). For another control option, discount this and enter the price of the control chosen.

For other types of combinations (up to 4 x 1) refer to page 96 for the different System Free indoor units and page 190 for the different controls.

## 1X1 UTOPIA IVX COMFORT WALL MOUNTED

SET NAME	INDOOR UNIT	OUTDOOR UNIT	CONTROL	PRICES
Utopia RPK 3 IVX.V.3M	RPK-3.0FSN3M	RAS - 3HVNC1	PC - ARFPE	
Utopia RPK 4 IVX.V.3M	RPK-4.0FSN3M	RAS - 4HVNC1E	PC - ARFPE	
Utopia RPK 4 IVX.3M	RPK-4.0FSN3M	RAS - 4HNC1E	PC - ARFPE	

## 1X1 UTOPIA IVX COMFORT DUCT

SET NAME	INDOOR UNIT	OUTDOOR UNIT	CONTROL	PRICES
Utopia RPI 3 IVX.V.C1	RPI - 3.0FSN4E	RAS - 3HVNC1	PC - ARFPE	
Utopia RPI 4 IVX.V.C1E	RPI - 4.0FSN4E	RAS - 4HVNC1E	PC - ARFPE	
Utopia RPI 4 IVX.C1E	RPI - 4.0FSN4E	RAS - 4HNC1E	PC - ARFPE	
Utopia RPI 5 IVX.V.C1E	RPI - 5.0FSN4E	RAS - 5HVNC1E	PC - ARFPE	
Utopia RPI 5 IVX.C1E	RPI - 5.0FSN4E	RAS - 5HNC1E	PC - ARFPE	
Utopia RPI 6 IVX.V.C1E	RPI - 6.0FSN4E	RAS - 6HVNC1E	PC - ARFPE	
Utopia RPI 6 IVX.C1E	RPI - 6.0FSN4E	RAS - 6HNC1E	PC - ARFPE	
Utopia RPI 5 IVX.V.C1E	RPI - 5.0FSN4E	RAS - 5HVNC1E	PC - ARFPE	
Utopia RPI 5 IVX.4E	RPI - 5.0FSN4E	RAS - 5HNC1E	PC - ARFPE	
Utopia RPI 6 IVX.V.4E	RPI - 6.0FSN4E	RAS - 6HVNC1E	PC - ARFPE	
Utopia RPI 6 IVX.4E	RPI - 6.0FSN4E	RAS - 6HNC1E	PC - ARFPE	
Utopia RPI 8 IVX.CE	RPI - 8.0FSN3E	RAS - 8HNCE	PC - ARFPE	
Utopia RPI 10 IVX.CE	RPI - 10.0FSN3E	RAS - 10HNCE	PC - ARFPE	

## 1X1 UTOPIA IVX COMFORT CEILING

SET NAME	INDOOR UNIT	OUTDOOR UNIT	CONTROL	PRICES
Utopia RPC 3 IVX.V.C1	RPC-3.0FSN3E	RAS - 3HVNC1	PC - ARFPE	
Utopia RPC 4 IVX.V.C1E	RPC-4.0FSN3E	RAS - 4HVNC1E	PC - ARFPE	
Utopia RPC 4 IVX.C1E	RPC-4.0FSN3E	RAS - 4HNC1E	PC - ARFPE	
Utopia RPC 5 IVX.V.C1E	RPC-5.0FSN3E	RAS - 5HVNC1E	PC - ARFPE	
Utopia RPC 5 IVX.C1E	RPC-5.0FSN3E	RAS - 5HNC1E	PC - ARFPE	
Utopia RPC 6 IVX.V.C1E	RPC-6.0FSN3E	RAS - 6HVNC1E	PC - ARFPE	
Utopia RPC 6 IVX.C1E	RPC-6.0FSN3E	RAS - 6HNC1E	PC - ARFPE	
Utopia RPC 3 IVX.V.3	RPC-3.0FSN3	RAS - 3HVNC1	PC - ARFPE	
Utopia RPC 4 IVX.V.3	RPC-4.0FSN3	RAS - 4HVNC1E	PC - ARFPE	
Utopia RPC 4 IVX.3	RPC-4.0FSN3	RAS - 4HNC1E	PC - ARFPE	
Utopia RPC 5 IVX.V.C1E	RPC-5.0FSN3	RAS - 5HVNC1E	PC - ARFPE	
Utopia RPC 5 IVX.3	RPC-5.0FSN3	RAS - 5HNC1E	PC - ARFPE	
Utopia RPC 6 IVX.V.3	RPC-6.0FSN3	RAS - 6HVNC1E	PC - ARFPE	
Utopia RPC 6 IVX.3	RPC-6.0FSN3	RAS - 6HNC1E	PC - ARFPE	

## 1X1 UTOPIA IVX COMFORT 800X800 4-WAY CASSETTE

SET NAME	INDOOR UNIT	OUTDOOR UNIT	CONTROL	PANEL	PRICES
Utopia RCI 3 IVX.V.C1	RCI - 3.0FSN4	RAS - 3HVNC1	PC - ARFPE	P N23NA2	
Utopia RCI 4 IVX.V.C1E	RCI - 4.0FSN4	RAS - 4HVNC1E	PC - ARFPE	P N23NA2	
Utopia RCI 4 IVX.C1E	RCI - 4.0FSN4	RAS - 4HNC1E	PC - ARFPE	P N23NA2	
Utopia RCI 5 IVX.V.C1E	RCI - 5.0FSN4	RAS - 5HVNC1E	PC - ARFPE	P N23NA2	
Utopia RCI 5 IVX.C1E	RCI - 5.0FSN4	RAS - 5HNC1E	PC - ARFPE	P N23NA2	
Utopia RCI 6 IVX.V.C1E	RCI - 6.0FSN4	RAS - 6HVNC1E	PC - ARFPE	P N23NA2	
Utopia RCI 6 IVX.C1E	RCI - 6.0FSN4	RAS - 6HNC1E	PC - ARFPE	P N23NA2	
Utopia RCI 3 IVX.V.C1.4	RCI - 3.0FSN4	RAS - 3HVNC1E	PC - ARFPE	P-APA160NA1	

**COMBINATIONS**  
OUTDOOR UNIT INVERTER

**UTOPIA IVX COMFORT**  
RAS - 3 ~ 6H(V)NC1E

**CAPACITY INDEX**

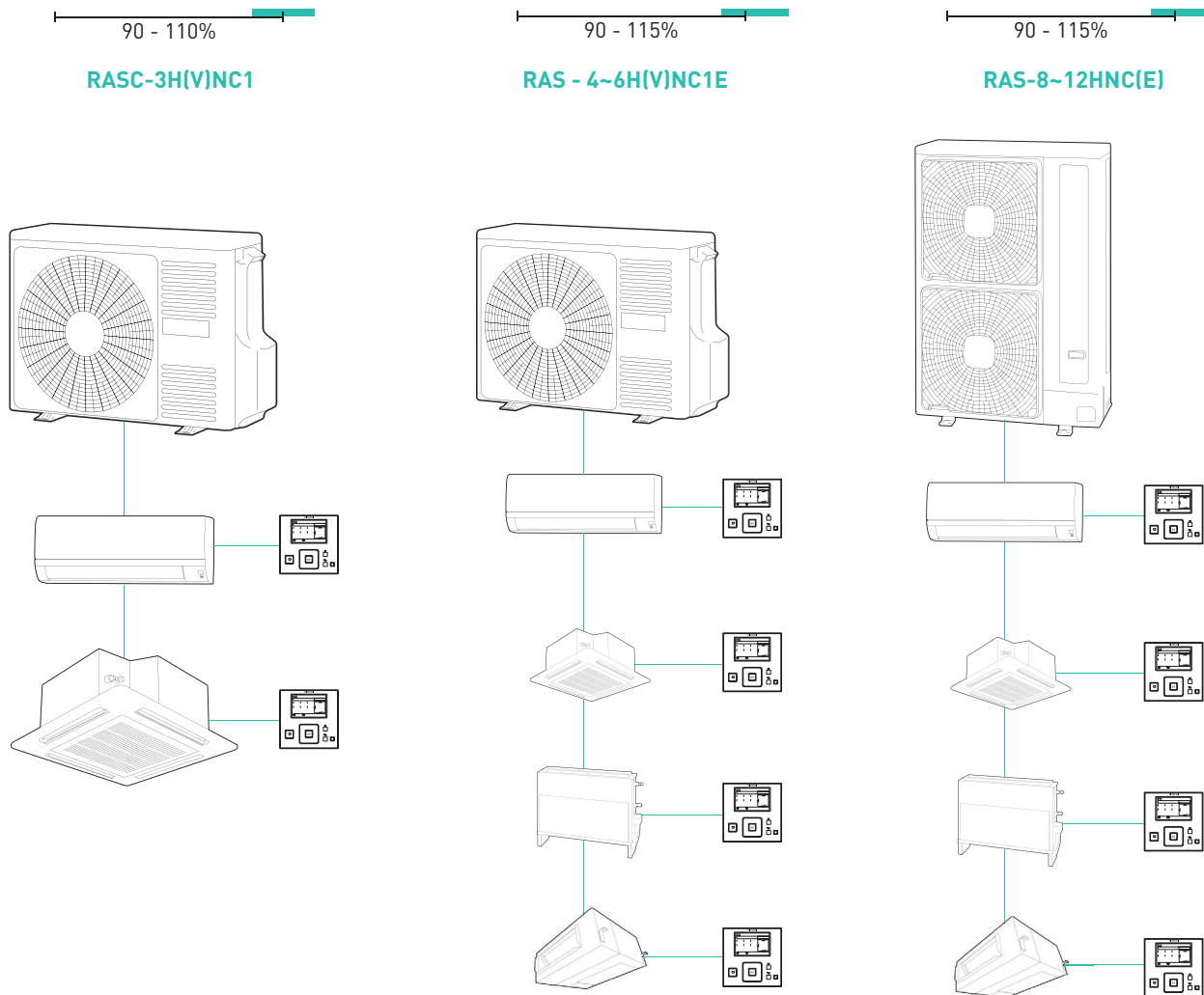

**CAPACITY INDEX IN RELATION TO COMBINATIONS**

COMBINATIONS	OUTDOOR UNIT MODEL			
	RAS - 3HVNC1	RAS - 4 H(V)NC1E	RAS - 5H(V)NC1E	RAS - 6 H(V)NC1E
Maximum number of connected indoor units	2	4		
Ratio of connected indoor units % (number of indoor units connected)	90~110% (1 unit)	90~115% (≤ 2 units)		
	90~100% (2 units)	90~100% (3 or 4 units)		
Connectable indoor unit minimum capacity (HP)	0.8 HP			
COMBINATIONS	OUTDOOR UNIT MODEL			
	RAS - 8HNC E	RAS - 10HNC E	RAS - 12HNC E	
Maximum number of connected indoor units	4			
Ratio of connected indoor units % (number of indoor units connected)	90~115%			
	90~115%			
Connectable indoor unit minimum capacity (HP)	1.8 HP			

### STANDARD REFRIGERANT DISTRIBUTION

All pipes behind the bifurcation pipes (B,C,D,E,F or G) must be balanced, and the differences between these Sections cannot be higher than indicated in the following tables

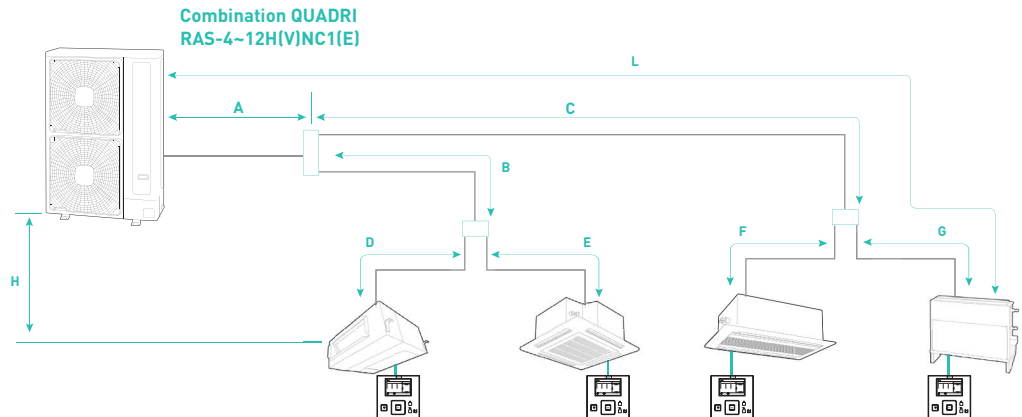
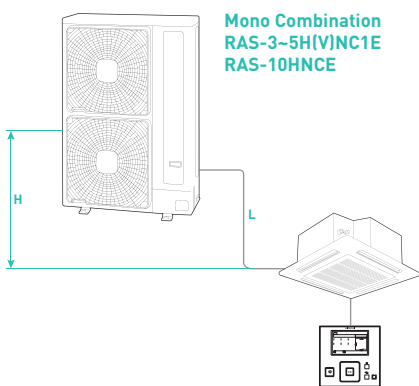
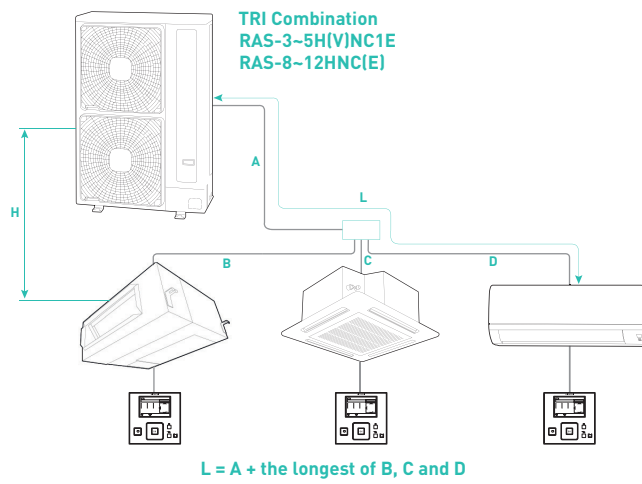
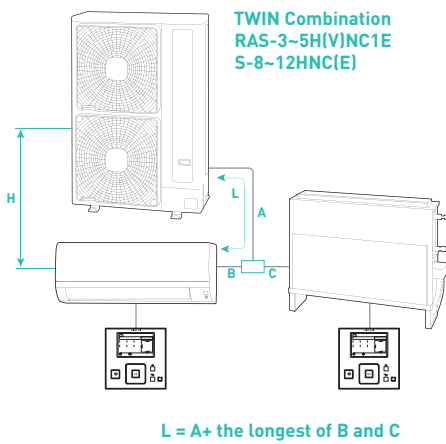

**NOTE: L AND H ARE LENGTH AND HEIGHT, RESPECTIVELY**  
In TWIN, TRI, QUADRI combinations, the length is the distance between the outdoor unit and the farthest indoor unit.

### MAXIMUM LENGTH OF STANDARD INSTALLATION PIPE

	RAS - 3HVNC1	RAS - 4 H(V)NC1E	RAS - 5H(V)NC1E	RAS - 6 H(V)NC1E	RAS - 8HNCE	RAS - 10HNCE	RAS - 12HNCE
Maximum pipe length between the outdoor unit and the farthest indoor unit.	Real pipe length	50	70	75	100		
	Equivalent pipe length	70	90	95	125		
Total maximum length.	TWIN (A + B + C)	60	80	85	100	115	
	TRI (A + B + C + D)	-	90	95	100	130	
	QUADRI (A + B + C + D + E + F + G)	-	90	95	100	145	
Maximum pipe length after the first derivation.	TWIN and TRI (B, C, D)	10			15		
	QUADRI (B + D, B + E, C + F, C + G)	-	10		15		
Main pipe length	A > B,C,D,E,F,G						
Maximum height difference: Outdoor unit higher than indoor unit / Indoor unit higher than outdoor unit	30/20						
Maximum height difference between the indoor units	3						
Maximum height difference between main branch pipe and indoor unit (TWIN, TRI, QUADRI) and between QUADRI branch pipes	3						
Difference of lengths between sections							
(B-C) (TWIN and TRI)	≤ 8						
(B-D) (TRI)							
(C-D) (TRI)							
(C+G)-(C+F) (QUADRI)							
(B+E)-(B+D) (QUADRI)							
(C+G)-(B+E) (QUADRI)							
(C+G)-(B+D) (QUADRI)							
(C+F)-(B+E) (QUADRI)							
(C+F)-(B+D) (QUADRI)							

Install the bifurcation pipe as close as possible to the indoor units.  
The liquid and gas pipes must have the same length and the same path.  
Install Multikits on the same horizontal level.



## STANDARD REFRIGERANT DISTRIBUTION OUTDOOR UNIT INVERTER

# UTOPIA IVX COMFORT

## RAS - 3 ~ 6H(V)NC1E

### PIPE LENGTH SPECIFICATIONS

Select pipe connection sizes with the following instructions:

Between the outdoor unit and the bifurcation pipe: Select the same size for connecting the pipes as for the outdoor unit.

Between the bifurcation pipe and the indoor unit: Select the same size for connecting the pipes as for the indoor unit.

PERFORMANCE	LIQUID	Ø 6.35				Ø 9.52				Ø 12.70				Ø 15.88					
		GAS	Ø 9.52	Ø 12.70	Ø 15.88	Ø 19.05	Ø 12.70	Ø 15.88	Ø 19.05	Ø 22.20	Ø 25.40	Ø 15.88	Ø 19.05	Ø 22.20	Ø 25.40	Ø 28.58	Ø 22.20	Ø 25.40	Ø 28.60
RAS - 3HVNC1	-	-	30 <sup>(1)(2)</sup>	30 <sup>(2)</sup>	-	30 <sup>(1)</sup>	50	-	-	-	-	-	-	-	-	-	-	-	-
RAS - 4 H(V)NC1E	-	-	-	5 <sup>(2)</sup>	5 <sup>(2)</sup>	40 <sup>(1)</sup>	70	50 <sup>(4)</sup>	-	-	30 <sup>(3)</sup>	30 <sup>(3)(4)</sup>	-	-	-	-	-	-	-
RAS - 5~6H(V)NC1E	-	-	-	5 <sup>(2)</sup>	5 <sup>(2)</sup>	40 <sup>(1)</sup>	75	50 <sup>(4)</sup>	-	-	30 <sup>(3)</sup>	30 <sup>(3)(4)</sup>	-	-	-	-	-	-	-
RAS - 8HNCE	-	-	-	-	-	-	-	50 <sup>(1)(4)</sup>	50 <sup>(1)</sup>	70 <sup>(5)(6)</sup>	-	50 <sup>(1)(3)(4)</sup>	50 <sup>(1)(3)</sup>	100	-	50 <sup>(1)(3)</sup>	50 <sup>(3)</sup>	-	-
RAS - 10~12HNCE	-	-	-	-	-	-	-	-	-	-	-	-	50 <sup>(1)</sup>	100	50	50 <sup>(1)(3)</sup>	50 <sup>(3)</sup>	50 <sup>(3)</sup>	50 <sup>(3)</sup>

[1] Reducing the size of the gas pipe will reduce the cooling capacity as there will be a greater loss of pressure in the gas pipe and the operating margin will be reduced.

[2] Reducing the size of the liquid pipe will reduce the operating range due to the ratio of the indoor unit to the capacity of the expansion valve.

[3] Increasing the size of the liquid pipe will require an additional refrigerant charge.

[4] When using gas pipes of Ø19.05, set pin 4 of the DSW2 on the outdoor unit's PCB to the ON position.

[5] If the pipe length is more than 70 m for 8 HP, use a liquid pipe of Ø12.70.

[6] In case of exceeding the recommended number of 8 HP connected indoor units (more than five units) use a Ø12.70 liquid pipe.

Standard specifications.

### CONNECTION SIZE OF THE EXTERNAL UNIT PIPES AND THE MULTIKIT

OUTDOOR UNIT		PIPE SIZE		MULTIKIT		
		LIQUID	GAS	TWIN	TRI	QUADRI
RAS - 3HVNC1	Inches	3/8"	5/8"	E-102SN4	E-102SN4	-
RAS - 4 H(V)NC1E		3/8"	5/8"		E-102SN4 MH-84AN1 <sup>(2)</sup>	E-102SN4
RAS - 5H(V)NC1E		3/8"	5/8"			
RAS - 6 H(V)NC1E		3/8"	5/8"	E-162SN4	E-162SN4 MH-84AN1 <sup>(2)</sup>	E-162SN4 MH-84AN1 <sup>(2)</sup>
RAS - 8HNCE		3/8" <sup>(1)</sup>	1"			
RAS - 10HNCE		1/2"	1"			
RAS - 12HNCE		1/2"	1"			

[1] If the pipe length [A+B or A+C or A+D] exceeds 70 m in 8 HP units, use a Ø12.70 liquid pipe.

[2] If you use the MH84AN1 multi-kit (TRI combination figure) it is not necessary to use multikit 2.

MULTI-KIT: SPLITTERS	PRICE
E-102SN4	
E-162SN4	
MH-84AN1	



Fisherman's Museum, Bermeo.  
Utopia Comfort

### REFRIGERANT DISTRIBUTION IN LINE (ONLY IVX COMFORT SERIES) RAS-4~12H(V)NC1(E)

This figure shows examples of 4 indoor units combined with an outdoor unit. Refrigerant pipes are shown as a single line in diagrams. However, the liquid and gas pipes are necessary in the installation.

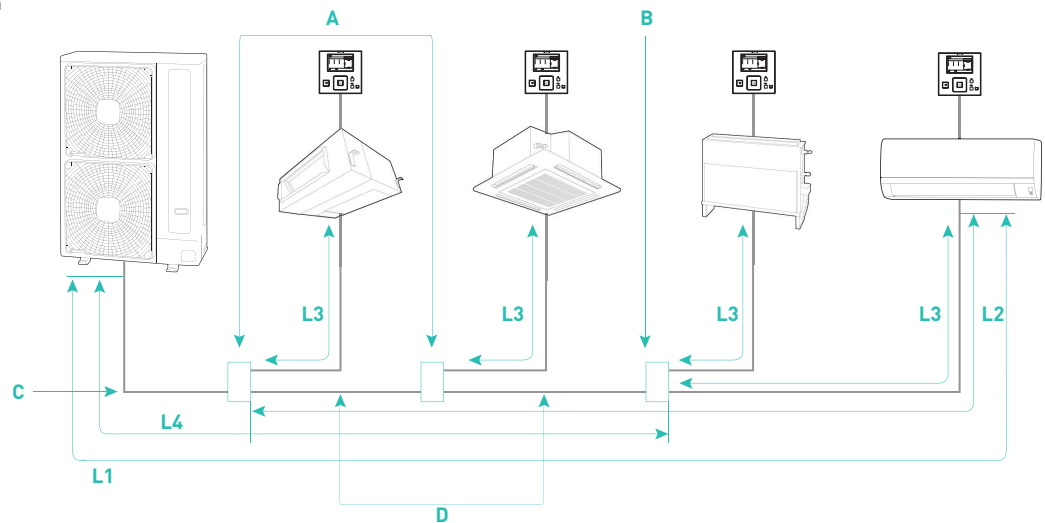

ELEMENT		RAS - 4H(V)NC1E	RAS - 5H(V)NC1E	RAS - 6H(V)NC1E	RAS - 8HNCE	RAS - 10HNCE	RAS - 12HNCE
Maximum pipe length between the outdoor unit and the farthest indoor unit.	Real length (L1)	70		75		100	
	Equivalent length	90		95		125	
Maximum length from the first branch pipe to each indoor unit (L2)			20			25	
Maximum pipe length from the branch pipe of the indoor unit (L3)			10			15	
Total pipe length L4 + (L3 1 + L3 2 + L3 3 ...)	m	70		75	100		145
Maximum height difference between the outdoor unit and the indoor unit / If the indoor unit is higher than the indoor unit.					30/20		
Maximum height difference between the indoor units					3		
Maximum height difference:							
Bifurcation / indoor pipes					3		
Bifurcation / outdoor pipes							

OUTDOOR UNIT	PIPE SIZE (C,D) (L4)mm		MULTI-KIT MODEL A	MULTI-KIT MODEL B
	LIQUID	GAS		
RAS - 3~6H(V)NC1E	3/8"	5/8"		E-102SN4
RAS-8HNCE	3/8" (1)	1"		E-162SN4
RAS-10~12HNC(E)	1/2"	1"		

(1) If the pipe length from the outside to the farthest indoor unit is more than 70 m in 8 HP units, use a liquid pipe of Ø12.70

### SIZE OF THE CONNECTING PIPES BETWEEN THE BIFURCATION PIPE AND THE INDOOR UNIT

TOTAL CAPACITY OF THE INDOOR UNIT	PIPE SIZE (Ø mm)	
	LIQUID	GAS
≤ 1.50 HP	1/4"	1/2"
1.80~2.00 HP	1/4"	5/8"
≥ 2.30 HP	3/8"	5/8"

- Combination pipe sizes: TWIN (B,C), TRI (B,C,D) and QUADRI (D,E,F and G).  
- Except in 8 and 10 HP units where connection is not possible.



AIR CONDITIONS UP TO  
**4 CENTRALIZED  
CONTROL INDOOR UNITS**

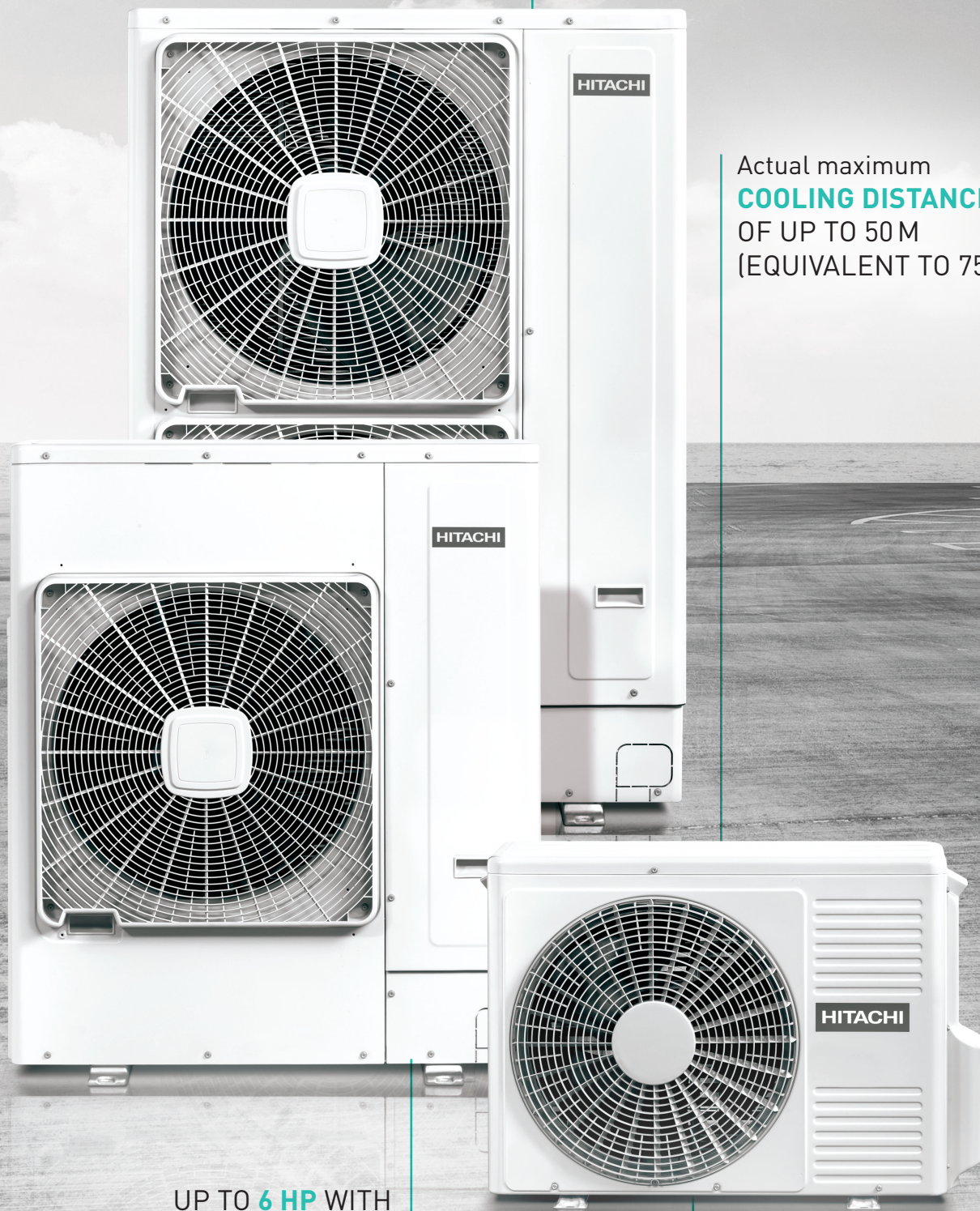

Actual maximum  
**COOLING DISTANCE**  
OF UP TO 50 M  
(EQUIVALENT TO 75 M)

UP TO **6 HP** WITH  
A SINGLE FAN. THE MOST  
COMPACT UNIT WITH A  
**HEIGHT OF 800 MM**

COMPLIES  
WITH EUROPEAN  
REGULATIONS  
**LOT.11 AND THE ERP.  
TIER 2 DIRECTIVE**



# UTOPIA ES

**Ideal solution for light commercial applications with diaphanous areas.**

**Easy installation** and maintenance even in the most complex conditions thanks to its compact design and access to all its components.

**Compatible** with all Hitachi centralized control and management systems.

Ideal for renovation of the air conditioning system.

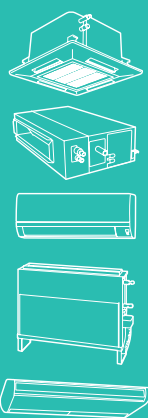

More information about compatible indoor units

▶ Page 98



More information about compatible controls and accessories

▶ Page 192

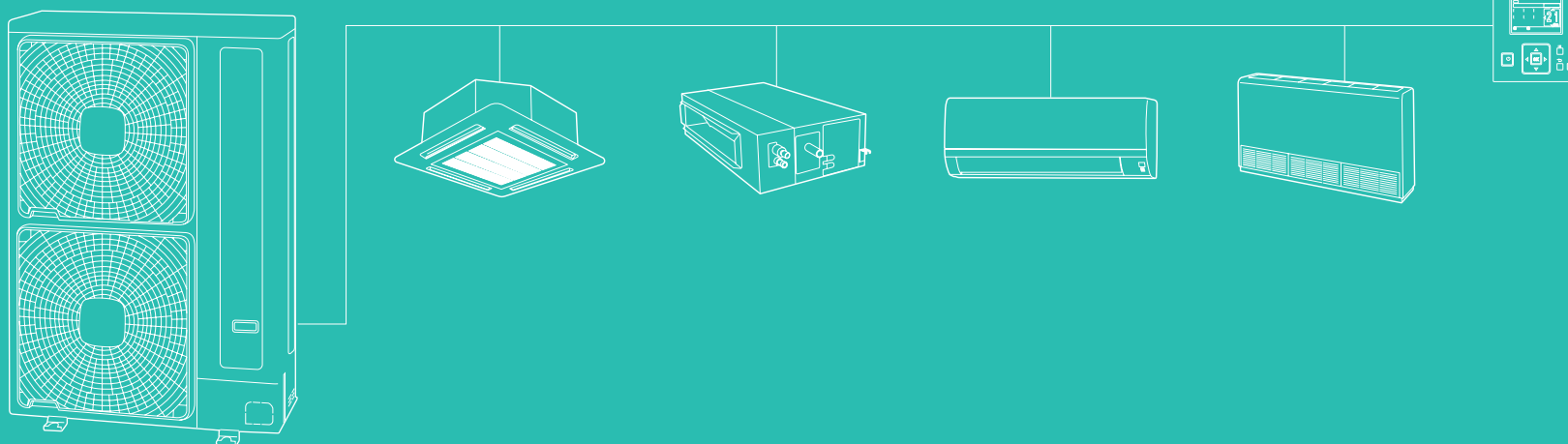

- Air conditions up to 4 indoor units
- Different fan speeds

## OUTDOOR UNIT INVERTER

# UTOPIA ES

RAS-3~10H(V)RNS2(3)E

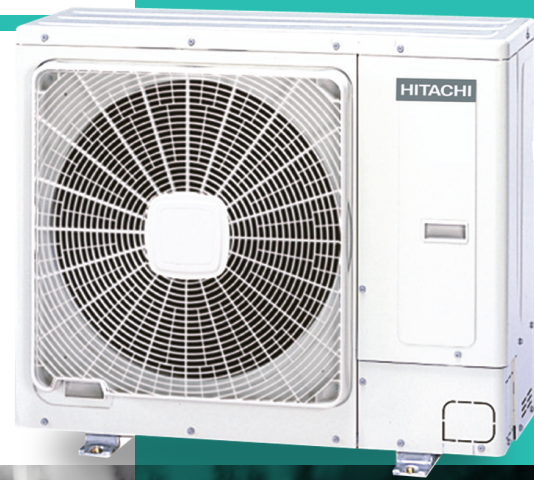

### CHARACTERISTICS

#### Light weight

It is one of the lightest systems on the market, and can be installed in small spaces.

#### Reduced refrigerant volume

Up to 30% less refrigerant, making installation easier.

#### Flexibility

Compatible with HITACHI System Free indoor units and individual and centralized management systems: CS-NET-WEB/MANAGER, BMS and H - Link II.

#### Optional DX-KIT

Integration of air curtains and air treatment units.

#### Compact size

Very small size, as it has a single high power fan, 4~6 HP, which requires less space for installation. The rest on the market have 2 fans.

#### Fan speed control

Conserves energy by controlling the fan speed, in addition to noise reduction at night.

#### Air conditioning of 4 indoor units with centralized control

Centralized temperature management.

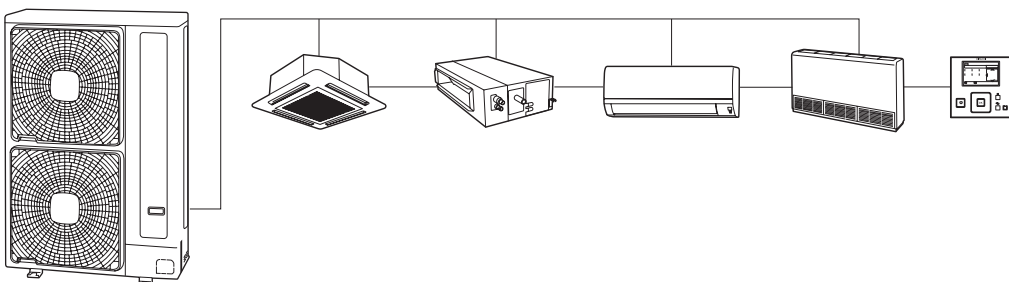

# UTOPIA ES

## UTOPIA ES SINGLE PHASE

OUTDOOR UNITS		RAS-3HVRNS3	RAS-4HVRNS3E	RAS-5HVRNS2E	RAS-6HVRNS2E
Nominal power <sup>(1)</sup>	Cooling	7.10 (3.20-8.00)	10.00 (4.50-11.20)	12.50 (5.70-14.00)	14.00 (6.00-16.00)
	Heating	8.00 (3.50-10.60)	11.20 (5.00-14.00)	14.00 (6.00-16.00)	16.00 (6.00-18.00)
Absorbed nominal power	Cooling	2.27	2.58	4.16	5.53
	Heating	2.00	2.56	4.18	5.38
EER - COP		More information, see page 133		2.91 - 3.24 (C/C)	2.45 - 2.88 (E/D)
Sound pressure level (night mode) <sup>(2)</sup>	dB(A)	48 (46)	50 (48)	52 (50)	55 (53)
Airflow	m <sup>3</sup> /h	2682	3720	4080	4800
Power supply		1-230 V 50 Hz			
Pipe diameter (Liq - Gas)	inches	3/8 - 5/8			
Maximum length	m	50			
Maximum height		30/20			
Refrigerant R410A Charge (pipe maximum length)	kg(m)	1.9 (50)	2.9 (50)		
Additional refrigerant charge	g/m	30	40	60	
Refrigerant		R410A			
Compressor		Scroll DC Inverter			
<b>PRICE</b>					

## UTOPIA ES THREE-PHASE

OUTDOOR UNITS		RAS-4HRNS3E	RAS-5HRNS2E	RAS-6HRNS2E	RAS-8HRNSE	RAS-10HRNSE
Nominal power <sup>(1)</sup>	Cooling	10.00 (4.50-11.20)	12.50 (5.70-14.00)	14.00 (6.00-16.00)	20.00 (9.00-22.40)	25.00 (11.20-28.00)
	Heating	11.20 (5.00-14.00)	14.00 (6.00-16.00)	16.00 (6.00-18.00)	22.40 (8.30-25.00)	28.00 (9.00-31.50)
Absorbed nominal power	Cooling	2.58	4.16	5.53	6.42	8.62
	Heating	2.56	4.18	5.38	6.33	8.44
EER - COP		For more info, see page 133	2.91 - 3.24 (A/C)	2.45 - 2.88 (E/D)	3.01 - 3.42 (B/D)	2.81 - 3.21 (A/C)
Sound pressure level (night mode) <sup>(2)</sup>	dB(A)	50 (48)	52 (50)	55 (53)	53 (51)	60 (56)
Airflow	m <sup>3</sup> /h	3720	4080	4080	7620	8760
Power supply		3 N-400 V 50 Hz				
Pipe diameter (Liq - Gas)	inches	3/8 - 5/8			3/8 - 1	1/2 - 1
Maximum length	m	50				
Maximum height		30/20				
Refrigerant R410A Charge (maximum pipe length)	kg(m)	2.9 (50)	2.9 (50)		6.0 (50)	6.2 (50)
Additional refrigerant charge	g/m	40	60		65	120
Refrigerant		R410A				
Compressor		Scroll DC Inverter				
<b>PRICE</b>						

(1) The nominal cooling and heating capacity is the combined capacity of the RASC system and is based on EN14511  
 - Cooling: Indoor temperature 27°C DB ; 9°C WB , Outdoor temperature 35°C DB  
 - Heating: Indoor temperature 20°C DB; outdoor temperature 7°C DB, 6°C WB. Pipe length: 7.5m

(2) The sound level measurement is performed in an anechoic camera at 1.5m below the unit (with duct). In night mode, the noise level decreases by 4 dB(A).

Guaranteed performance

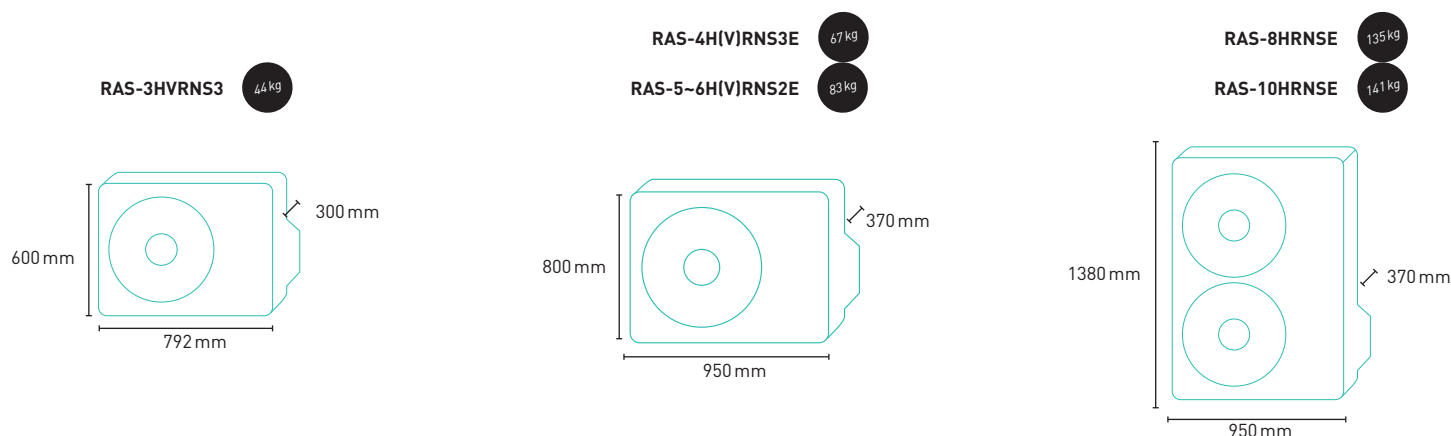
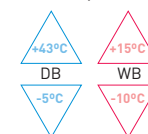

For more information about controls, see page 199.  
 Recommended prices - VAT not included, Waste Electrical and Electronic Equipment Directive (WEEE) fee not included.  
 To create the energy label visit our website [www.hitachiircon.es](http://www.hitachiircon.es) and use our Hitachi ErP AcTive Tool application.



## ENERGY CLASS

### OUTDOOR UNIT INVERTER

# UTOPIA ES

## RAS-3~10H(V)RNS2(3)E

Since January 1, 2015, the European Union's Eco-design ErP regulations affect air conditioning units of less than 12 kW (ErP.Tier 2 Directive). Therefore, the SEER and SCOP seasonal yields must be shown in these units, which provide a more accurate estimate of the actual performance of the product during the period in use.

### STANDARD CAPACITY IN COOLING AND HEATING

COMBINATIONS		COOLING			HEATING		
OUTDOOR UNIT	INDOOR UNIT	SEER	ENERGY CLASS	P DESIGN (35°C)	SCOP	ENERGY CLASS	P DESIGN (-10°C)
				KW			KW
RAS-3HVRNS3	RCI-3,0FSN4	5.14	A	7.10	3.88	A	5.60
	RPC-3,0FSN3E	4.31	C	7.10	3.80	A	5.60
	RPI-3,0FSN4E	4.51	C	7.10	3.81	A	5.60
	RPK-3,0FSN3M	4.66	B	7.10	3.80	A	5.60
RAS-4HVRNS3E	RCI-4,0FSN4	4.95	B	10.00	3.85	A	8.00
	RPI-4,0FSN4E	4.61	B	10.00	3.80	A	8.00
RAS-4HRNS3E	RCI-4,0FSN4	4.85	B	10.00	3.85	A	8.00
	RPI-4,0FSN4E	4.54	C	10.00	3.80	A	8.00

Tecnoláser Clinic Vision, Seville.  
Utopia ES  
More info: [www.hitachiaircon.es](http://www.hitachiaircon.es)



# MONO COMBINATIONS

These examples of mono combinations have been calculated with the PC-ARF PE control (not standard). For another control option, discount this and enter the price of the control chosen.

For other types of combinations (up to 4 x 1) refer to page 96 for the different System Free indoor units and page 190 for the different controls.

## 1X1 UTOPIA ES WALL MOUNTED

SET NAME	INDOOR UNIT	OUTDOOR UNIT	CONTROL	PRICES
Utopia.RPK.3ES.V.3M	RPK-3.0FSN3M	RAS-3HVRNS3	PC - ARFPE	

## 1X1 UTOPIA ES 2-WAY CASSETTE

SET NAME	INDOOR UNIT	OUTDOOR UNIT	CONTROL	PANEL	PRICES
Utopia.RCD5.ES.V.3	RCD-5.0FSN3	RAS-5HVRNS2E	PC - ARFPE	P N23DNA	
Utopia.RCD5.ES.3	RCD-5.0FSN3	RAS-5HRNS2E	PC - ARFPE	P N23DNA	

## 1X1 UTOPIA ES DUCT

SET NAME	INDOOR UNIT	OUTDOOR UNIT	CONTROL	PRICES
Utopia.RPI.3ES.V.4E	RPI - 3.0FSN4E	RAS-3HVRNS3	PC - ARFPE	
Utopia.RPI.4ES.V.4E	RPI - 4.0FSN4E	RAS-4HVRNS3E	PC - ARFPE	
Utopia.RPI.4ES.4E	RPI - 4.0FSN4E	RAS-4HRNS3E	PC - ARFPE	
Utopia.RPI.5ES.V.4E	RPI - 5.0FSN4E	RAS-5HVRNS2E	PC - ARFPE	
Utopia.RPI5.ES.4E	RPI - 5.0FSN4E	RAS-5HRNS2E	PC - ARFPE	
Utopia.RPI6.ES.V.4E	RPI - 6.0FSN4E	RAS-6HVRNS2E	PC - ARFPE	
Utopia.RPI6.ES.4E	RPI - 6.0FSN4E	RAS-6HRNS2E	PC - ARFPE	
Utopia.RPI8.ES.3E	RPI - 8.0FSN3E	RAS-8HRNS2E	PC - ARFPE	
Utopia.RPI10.ES.3E	RPI - 10.0FSN3E	RAS-10HRNS2E	PC - ARFPE	

## 1X1 UTOPIA ES 800X800 4-WAY CASSETTE

SET NAME	INDOOR UNIT	OUTDOOR UNIT	CONTROL	PANEL	PRICES
Utopia.RCI3.ES.V.4	RCI - 3.0FSN4	RAS-3HVRNS3	PC - ARFPE	P N23NA2	
Utopia.RCI4.ES.V.4	RCI - 4.0FSN4	RAS-4HVRNS3E	PC - ARFPE	P N23NA2	
Utopia.RCI4.ES.4	RCI - 4.0FSN4	RAS-4HRNS3E	PC - ARFPE	P N23NA2	
Utopia.RCI5.ES.V.4	RCI - 5.0FSN4	RAS-5HVRNS2E	PC - ARFPE	P N23NA2	
Utopia.RCI5.ES.4	RCI - 5.0FSN4	RAS-5HRNS2E	PC - ARFPE	P N23NA2	
Utopia.RCI6.ES.V.4	RCI - 6.0FSN4	RAS-6HVRNS2E	PC - ARFPE	P N23NA2	
Utopia.RCI6.ES.4	RCI - 6.0FSN4	RAS-6HRNS2E	PC - ARFPE	P N23NA2	

## 1X1 UTOPIA ES CEILING

SET NAME	INDOOR UNIT	OUTDOOR UNIT	CONTROL	PRICES
Utopia.RPC3.ES.V.3E	RPC-3.0FSN3E	RAS-3HVRNS3	PC - ARFPE	
Utopia.RPC5.ES.V.3E	RPC-5.0FSN3E	RAS-5HVRNS2E	PC - ARFPE	
Utopia.RPC5.ES.3E	RPC-5.0FSN3E	RAS-5HRNS2E	PC - ARFPE	
Utopia.RPC6.ES.V.3E	RPC-6.0FSN3E	RAS-6HVRNS2E	PC - ARFPE	
Utopia.RPC6.ES.3E	RPC-6.0FSN3E	RAS-6HRNS2E	PC - ARFPE	
Utopia.RPC3.ES.V.3	RPC-3.0FSN3	RAS-3HVRNS3	PC - ARFPE	
Utopia.RPC5.ES.V.3	RPC-5.0FSN3	RAS-5HVRNS2E	PC - ARFPE	
Utopia.RPC5.ES.3	RPC-5.0FSN3	RAS-5HRNS2E	PC - ARFPE	
Utopia.RPC6.ES.V.3	RPC-6.0FSN3	RAS-6HVRNS2E	PC - ARFPE	
Utopia.RPC6.ES.3	RPC-6.0FSN3	RAS-6HRNS2E	PC - ARFPE	

Recommended prices - VAT not included, Waste Electrical and Electronic Equipment Directive (WEEE) fee not included.

## COMBINATIONS

### OUTDOOR UNIT INVERTER

# UTOPIA ES

## RAS-3~10H(V)RNS2(3)E

### COMBINATION TABLE RAS-3~4H(V)RNS3(E)

RAS-3 HVRNS3					NOMINAL COOLING CAPACITY 7.10 KW							
					NOMINAL HEATING CAPACITY 8.00 KW							
COMBINATION	INDOOR UNIT COMBINATION (HP)			TOTAL	MAXIMUM CAPACITY (KW)							
					COOLING				HEATING			
									TOTAL			
MONO	3.00	-	-	3.00	8.00	-	-	8.00	10.60	-	-	10.60
TWIN	1.50	1.50	-	3.00	4.00	4.00	-	8.00	5.30	5.30	-	10.60
RAS-4 HVRNS3E					NOMINAL COOLING CAPACITY 10.00 KW							
					NOMINAL HEATING CAPACITY 11.20 KW							
COMBINATION	INDOOR UNIT COMBINATION (HP)			TOTAL	MAXIMUM CAPACITY (KW)							
					COOLING				HEATING			
									TOTAL			
MONO	4.00	-	-	4.00	11.20	-	-	11.20	14.00	-	-	14.00
TWIN	2.00	2.00	-	4.00	5.60	5.60	-	11.20	7.00	7.00	-	14.00
	(2.30)	(1.80)	-	4.10	6.30	4.90	-	11.20	7.90	6.10	-	14.00
	(2.30)	2.00	-	4.30	6.00	5.20	-	11.20	7.50	6.50	-	14.00
	2.50	(1.80)	-	4.30	6.50	4.70	-	11.20	8.10	5.90	-	14.00
	2.50	2.00	-	4.50	6.20	5.00	-	11.20	7.80	6.20	-	14.00

### COMBINATION TABLE RAS-5~6H(V)RNS2(E) AND RAS-8~10HRNSE

RAS - 5H(V)RNS2E					NOMINAL COOLING CAPACITY 12.50 KW							
					NOMINAL HEATING CAPACITY 14.00 KW							
COMBINATION	INDOOR UNIT COMBINATION (HP)			TOTAL	MAXIMUM CAPACITY (KW)							
					COOLING				HEATING			
									TOTAL			
MONO	5.00	-	-	5.00	14.00	-	-	14.00	16.00	-	-	16.00
TWIN	2.50	2.50	-	5.00	7.00	7.00	-	14.00	8.00	8.00	-	16.00
	3.00	(2.30)	-	5.30	7.90	6.10	-	14.00	9.10	6.90	-	16.00
	3.00	(1.80)	-	4.80	8.80	5.30	-	14.00	10.00	6.00	-	16.00
	3.00	2.00	-	5.00	8.40	5.60	-	14.00	9.60	6.40	-	16.00
RAS - 6H(V)RNS2E					NOMINAL COOLING CAPACITY 14.00 KW							
					NOMINAL HEATING CAPACITY 16.00 KW							
COMBINATION	INDOOR UNIT COMBINATION (HP)			TOTAL	MAXIMUM CAPACITY (KW)							
					COOLING				HEATING			
									TOTAL			
MONO	6.00	-	-	6.00	16.00	-	-	16.00	18.00	-	-	18.00
TWIN	3.00	3.00	-	6.00	8.00	8.00	-	16.00	9.00	9.00	-	18.00
	3.00	2.50	-	5.50	8.70	7.30	-	16.00	9.80	8.20	-	18.00
TRI	(1.80)	(1.80)	(1.80)	5.40	5.30	5.30	5.30	16.00	6.00	6.00	6.00	18.00
	2.00	2.00	2.00	6.00	5.30	5.30	5.30	16.00	6.00	6.00	6.00	18.00
	2.00	2.00	(1.80)	5.80	5.50	5.50	5.50	16.00	6.20	6.20	5.60	18.00
	(1.80)	(1.80)	2.00	5.60	5.10	5.10	5.70	16.00	5.80	5.80	6.40	18.00
	1.50	1.50	2.50	5.50	4.40	4.40	7.30	16.00	4.90	4.90	8.20	18.00

The RPF(I) unit cannot be connected to another unit in a TWIN or TRI combination due to the limitation of height difference between indoor units.

The UTOPIA ES series is only for the simultaneous operation of TWIN, TRI, QUADRI combinations. Triple combination is not available for RAS-10HRNSE. In parentheses ( ): Adjusted capacity.



PIPE LENGTH

RAS - 8HRNSE						NOMINAL COOLING CAPACITY 20.00 KW									
						NOMINAL HEATING CAPACITY 22.40 KW									
						MAXIMUM CAPACITY (KW)									
COMBINATION	Indoor unit combination (HP)				Total	Cooling					Heating				
						Total					Total				
MONO	8.00	-	-	-	8.00	22.40	-	-	-	22.40	25.00	-	-	-	25.00
TWIN	4.00	4.00	-	-	8.00	11.20	11.20	-	-	22.40	12.50	12.50	-	-	25.00
TRI	3.00	3.00	3.00	-	9.00	7.40	7.40	7.40	-	22.40	8.30	8.30	8.30	-	25.00
QUADRI	2.00	2.00	2.00	2.00	8.00	5.60	5.60	5.60	5.60	22.40	6.20	6.20	6.20	6.20	25.00

RAS - 10HRNSE						NOMINAL COOLING CAPACITY 25.00 KW									
						NOMINAL HEATING CAPACITY 28.00 KW									
						MAXIMUM CAPACITY (KW)									
COMBINATION	Indoor unit combination (HP)				Total	Cooling					Heating				
						Total					Total				
MONO	10.00	-	-	-	10.00	28.00	-	-	-	28.00	31.50	-	-	-	31.50
TWIN	5.00	5.00	-	-	10.00	14.00	14.00	-	-	28.00	15.70	15.70	-	-	31.50
QUADRI	2.50	2.50	2.50	2.50	10.00	7.00	7.00	7.00	7.00	28.00	7.80	7.80	7.80	7.80	31.50

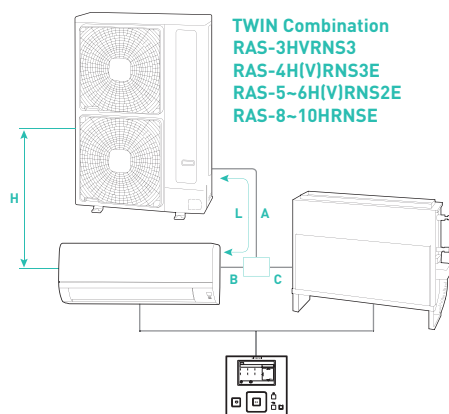
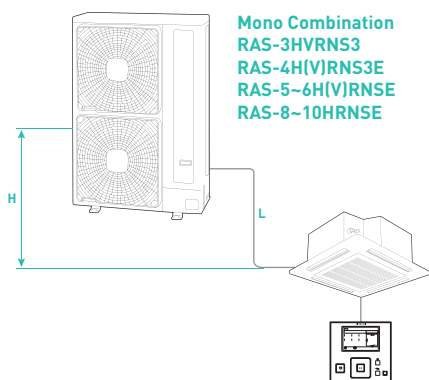

$L = A + \text{the longest of B and C}$

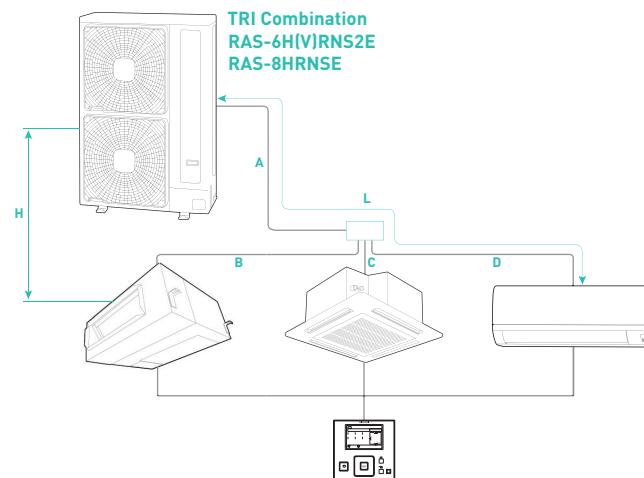

$L = A + \text{the longest of B, C and D}$

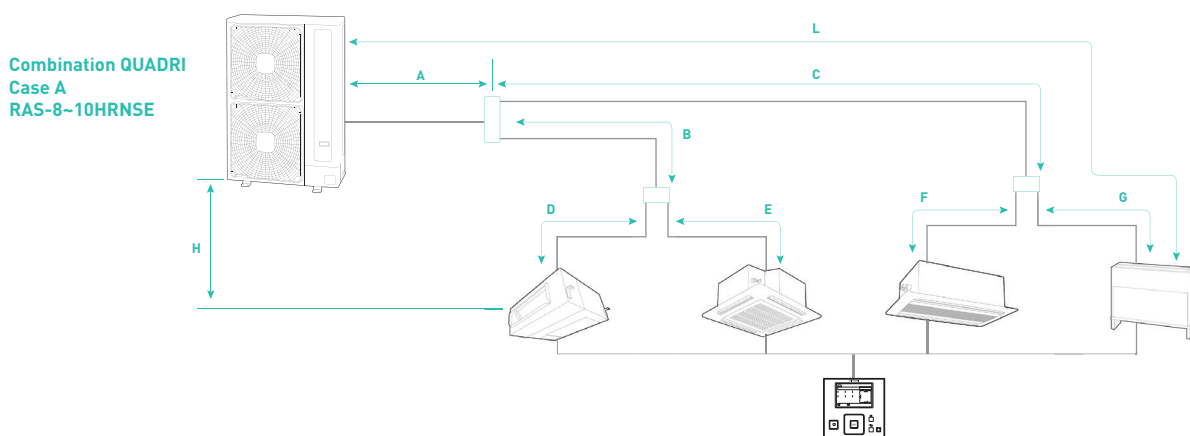

$L = A + \text{the longest of [B plus the longest of D and E] and [C+ the longest of F and G]}$

NOTE: L and H are the length and the height, respectively.  
In TWIN, TRI, QUADRI combinations, the length is the distance between the outdoor unit and the farthest indoor unit.

ATTENTION

- The refrigerant pipes length between the Outdoor Unit and the first bifurcation should be greater than the length of the pipes between the first bifurcation and the farthest indoor unit.
- The liquid and gas pipes must be of the same length and have the same path.
  - Multikits for multiple connections (optional accessory such as system parts) must be used to install the bifurcation pipe of the indoor unit.
  - Install the Multikits on the same horizontal level.

## STANDARD REFRIGERANT DISTRIBUTION OUTDOOR UNIT INVERTER

# UTOPIA ES

## RAS-3~10H(V)RNS2(3)E

### MAXIMUM LENGTH OF STANDARD INSTALLATION PIPE

ELEMENT		RAS-3HVRNS3	RAS-4H(V)RNS3E	RAS-5~6H(V)RNS2E	RAS-8~10HRNSE
Maximum pipe length between the outdoor unit and the farthest indoor unit (L).	Real pipe length	50	50	50	50
	Equivalent pipe length	70	70	70	70 <sup>(1)</sup>
Maximum height difference between indoor and outdoor units (H)	Outdoor unit higher than the indoor unit	30	30	30	30
	Indoor unit higher than the outdoor unit	20	20	20	20
	Height difference between the indoor units	0.50	0.50	0.50	0.50
Total maximum pipe length	TWIN (A + B + C)	60	60	60	60
	TRI (A + B + C + D)	-	-	70	70
	QUADRI Case A: (A+B+C+D+E+F+G)	-	-	-	80

(1) QUADRI 75 m

After the bifurcation pipe (B, C, D, E, F or G), the pipe length should be less than the values shown in the following table:

		RAS-3~4H(V)RNS3(E) and RAS-5H(V)RNS2E	RAS-6H(V)RNS2E	RAS-8~10HRNSE
TWIN	B, C (m)	10	10	10
TRI	B, C, D (m)	-	10	10
QUADRI	Case A: (B+D, B+E, C+F, C+G) (m)	-	-	10

All pipes after the bifurcation pipe (B, C, D, E, F or G) must be balanced, and the difference between these sections cannot be greater than that indicated in the following tables:

		RAS-3~4H(V)RNS3(E) and RAS-5H(V)RNS2E	RAS-6H(V)RNS2E	RAS-8~10HRNSE
TWIN	B, C (m)	8	8	8
TRI	B, C, D (m)	-	8	8
QUADRI	Case A: Difference between: B + (D/E) and C (F/G) between D and E between F and G	-	-	8

### PIPE LENGTH SPECIFICATIONS

PERFORMANCE CAPACITY	LIQUID GAS	Ø 6.35				Ø 9.52				Ø 12.70				Ø 12.70 <sup>(5)</sup>			
		Ø 9.52	Ø 12.70	Ø 15.88	Ø 19.05	Ø 12.70	Ø 15.88	Ø 19.05	Ø 22.20	Ø 25.40	Ø 15.88	Ø 19.05	Ø 22.20	Ø 25.40	Ø 28.60	Ø 25.40	Ø 28.60
RAS-3HVRNS3	-	30 <sup>(1)(2)</sup>	30 <sup>(2)</sup>	-	30 <sup>(1)</sup>	50	-	-	-	-	-	-	-	-	-	-	-
RAS-4H(V)RNS3E	-	-	5 <sup>(2)</sup>	5 <sup>(2)</sup>	40 <sup>(1)</sup>	50 <sup>(4)</sup>	50 <sup>(4)</sup>	-	-	30 <sup>(3)</sup>	30 <sup>(3)(4)</sup>	-	-	-	-	-	-
RAS-5H(V)RNS2E	-	-	5 <sup>(2)</sup>	5 <sup>(2)</sup>	40 <sup>(1)</sup>	50 <sup>(4)</sup>	50 <sup>(4)</sup>	-	-	30 <sup>(3)</sup>	30 <sup>(3)(4)</sup>	-	-	-	-	-	-
RAS-6H(V)RNS2E	-	-	5 <sup>(2)</sup>	5 <sup>(2)</sup>	40 <sup>(1)</sup>	50 <sup>(4)</sup>	50 <sup>(4)</sup>	-	-	30 <sup>(3)</sup>	30 <sup>(3)(4)</sup>	-	-	-	-	-	-
RAS-8HRNSE	-	-	-	-	-	-	30 <sup>(1)</sup>	30 <sup>(1)</sup>	50	-	30 <sup>(1)(3)(4)</sup>	30 <sup>(1)(3)</sup>	30 <sup>(3)</sup>	-	-	-	-
RAS-10HRNSE	-	-	-	-	-	-	-	-	-	30 <sup>(5)</sup>	-	-	30 <sup>(1)(3)</sup>	50 <sup>(3)(5)</sup>	50 <sup>(3)</sup>	20 <sup>(3)</sup>	20 <sup>(3)</sup>

(1) Reducing the size of the gas pipe will reduce the cooling capacity as there will be a greater loss of pressure in the gas pipe and the operating margin will be reduced.

(2) Reducing the size of the liquid pipe will reduce the operating range due to the ratio of the indoor unit to the capacity of the expansion valve.

(3) Increasing the size of the liquid pipe will require an additional refrigerant charge.

(4) When using gas pipes of Ø19.05, set pin 4 of the DSW2 on the outdoor unit's PCB to the ON position.

(5) If the pipe length is more than 70 m for 8 HP, use a liquid pipe of Ø12.70.

In case of exceeding the recommended number of 8 HP connected indoor units (more than five units) use a Ø12.70 liquid pipe.

Standard specifications.

### CONNECTION SIZE OF THE EXTERNAL UNIT PIPES AND THE MULTIKIT

Select pipe connection sizes with the following instructions:  
Between the outdoor unit and the bifurcation pipe:  
Select the same size for connecting the pipes as for the outdoor unit.

Between the first and second bifurcation pipes for RAS-8-10HRNSE.

Between the bifurcation pipe and the indoor unit:  
Select the same size for connecting the pipes as for the indoor unit.

OUTDOOR UNIT	PIPE SIZE <sup>(0)</sup>		MULTIKIT			
	LIQUID	GAS	TWIN	TRI	QUADRI	
RAS-3HVRNS3	3/8"	5/8"	E-102SN4	-	-	
RAS-4H(V)RNS3E	3/8"	5/8"		E-102SN4	E-102SN4	E-102SN4
RAS-5H(V)RNS2E	3/8"	5/8"				
RAS-6H(V)RNS2E	3/8"	5/8"				
RAS - 8HRNSE	3/8"	1"	E-162SN4	E-162SN4 MH-84AN1 <sup>(2)</sup>	E-162SN4	
RAS - 10HRNSE	3/8" <sup>(1)</sup>	1"				

(0) The sizes of the indoor and outdoor units are different. Adjust the conical adapter (accessory) to the indoor pipe connection.  
(1) Select 0.95 cm pipe size when the pipe length is greater than 30 m (RAS-10HRNSE only)

MULTI-KIT: SPLITTERS	PRICE
E-102SN4	
E-162SN4	
MH-84AN1	

### PIPE CONNECTION SIZE BETWEEN THE FIRST AND SECOND BIFURCATION PIPE RAS-8~10HRNSE

TOTAL CAPACITY OF INDOOR UNITS AFTER CONNECTING THE SECOND BIFURCATION PIPE	PIPE SIZE (Diameter in mm)	
	LIQUID	GAS
≤ 2.30 HP	1/4"	1/2"
≤ 6.00 HP	3/8"	5/8"

### CONNECTION SIZE OF INDOOR UNIT PIPES INDOOR

INDOOR UNIT	PIPE SIZE	
	LIQUID	GAS
1.50 HP	1/4"	1/2"
2.00 HP	1/4"	5/8"
2.50~6 HP	3/8"	5/8"
8 HP	3/8"	3/4 --> 1" <sup>(1)</sup>
10 HP	3/8" <sup>(2)</sup>	7/8 --> 1" <sup>(1)</sup>

If pipes other than standard values are used, the installer will supply pipe reducers.  
(1) The indoor pipe adapters of ø19.5 -> ø25.4 and ø22.2 -> ø25.4 are supplied from the factory with the indoor unit.  
(2) Change the size of the liquid pipe to ø12.70mm when the length is greater than 30m. The indoor pipe adapter is supplied from the factory with the indoor unit.  
\* The gas pipe diameter of the RCIM-2FSN4E indoor unit is 32.25cm

Recommended prices - VAT not included, Waste Electrical and Electronic Equipment Directive (WEEE) fee not included.



COMMERCIAL



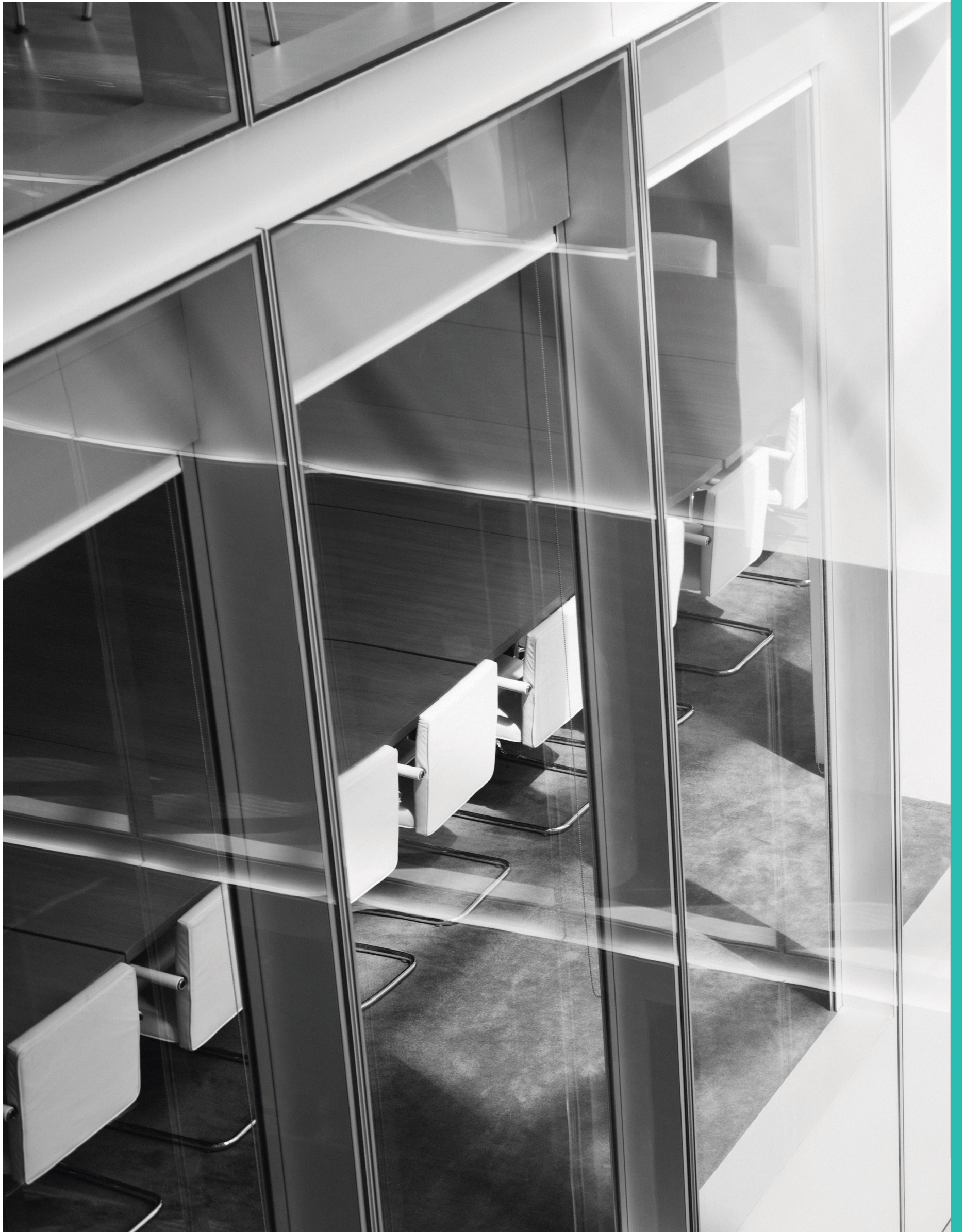



# VRF SYS TEMS SET FREE





# VRF SYSTEMS

<b>VRF SYSTEMS - SET FREE</b>	<b>142</b>
CENTRIFUGAL VRF	143
UTOPIA IVX PREMIUM	153
VRF MINI SIDE FLOW	163
RAS-FSVN3E / FSNY3E	165
RAS-FSNM	167
VRF SET FREE HIGH EFFICIENCY	169
RAS-FSXN1E	171
RAS-FSXNH(E)	175

# CENTRIFUGAL VRF



More information  
about compatible  
controls and  
accessories

Page 192

**Air-conditions all types of businesses at the street level:** restaurants, shops, clinics and offices. The efficient alternative to conventional autonomous and axial systems.

**It expels air outside** no matter where the outdoor unit is installed. Thanks to the centrifugal fan, it is also silent under all circumstances.

An **aesthetic solution**, thanks to its hidden installation and combinability with the indoor units; it fits in with the decoration of the establishment.

**Ease of installation and simple and immediate maintenance** in the establishment itself.

**Higher performance with the frequency inverter** core of the centrifugal VRF system. Connects, controls and manages system operation.

**Accuracy of the cooling circuit**, which regulates the exact amount of refrigerant for its operation.

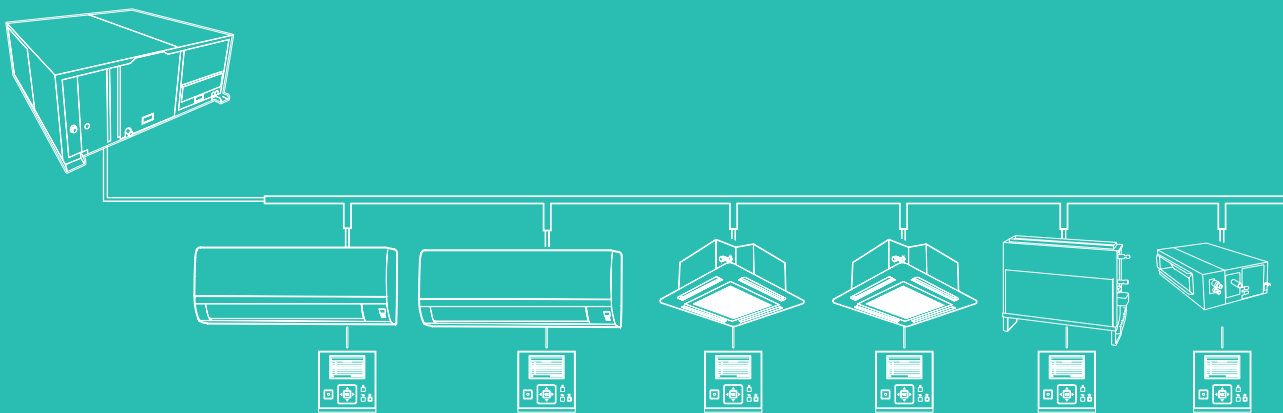

**CENTRIFUGAL  
VRF  
INTEGRATES  
PREVIOUSLY  
INCOMPATIBLE  
CONCEPTS**

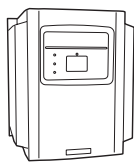

Variable frequency drive,  
Hitachi's own



Watch the video



More information [www.vrfcentrifugo.com](http://www.vrfcentrifugo.com)



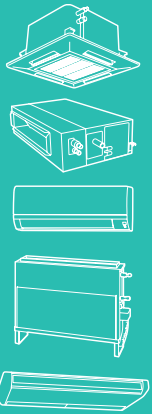

More information about compatible indoor units

▶ Page 96

FLEXIBILITY IN INSTALLATION, ITS WIDE RANGE ALLOWS FREE COMBINATIONS THAT ADAPT TO ANY AIR CONDITIONING PROJECT

AIR CONDITIONING OF UP TO 6 DIFFERENT SPACES, WITH INDEPENDENT CONTROL

INSTALLATION HIDDEN IN THE FACADE (FALSE CEILING)

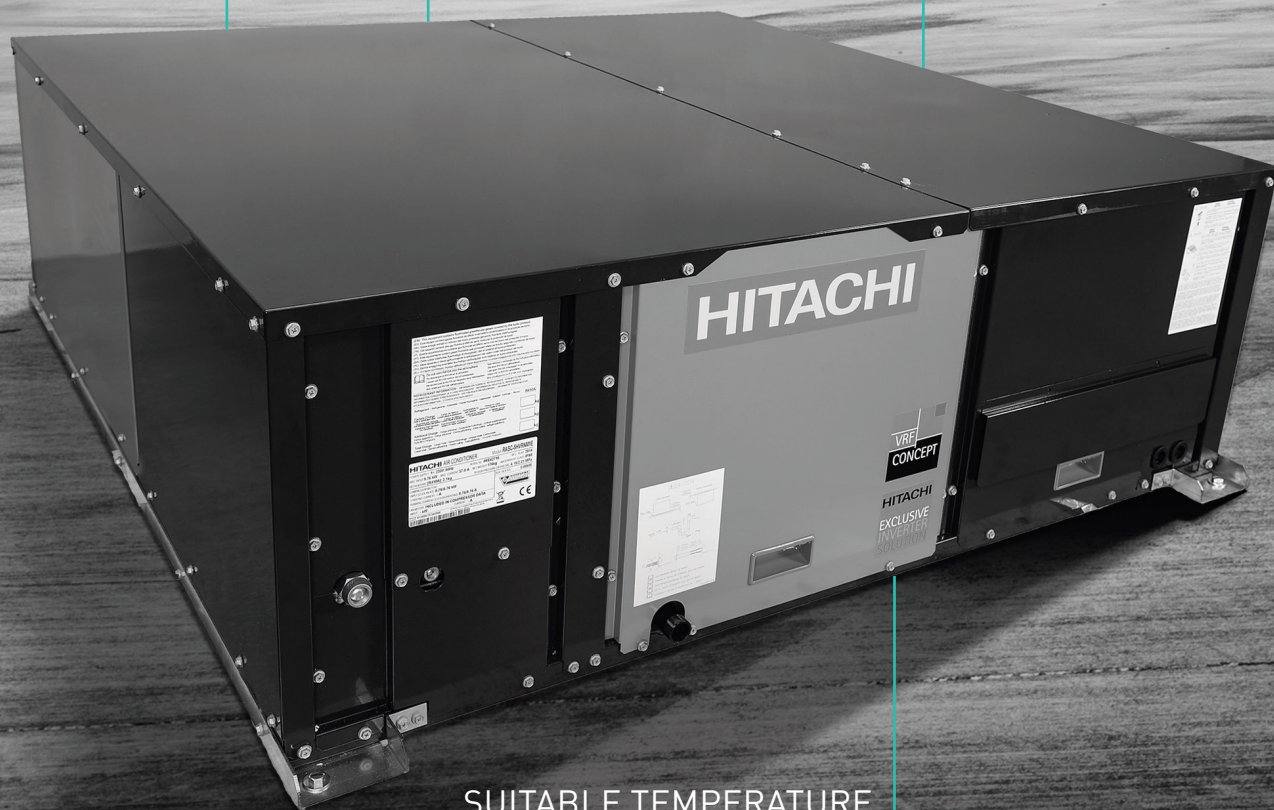

SUITABLE TEMPERATURE FOR EACH ROOM, SO THAT PEOPLE FEEL COMFORTABLE



## OUTDOOR UNIT MULTI INVERTER

### VRF RASC-4~10HNPE



#### CHARACTERISTICS

##### **Air conditioning for all types of businesses at the street level:**

restaurants, shops, clinics and offices.

##### **Zoning**

Air conditioning of 6 different spaces with different temperatures and individual controls.

##### **Flexibility**

Compatible with any of the System Free indoor units.

##### **Optimized refrigerant cycle**

With an improved pressure control and a new accumulator.

##### **Multiple control options**

Compatible with all Hitachi control and management systems, BMS systems and Modbus protocols, KNX.

##### **VRF with centrifugal fan**

Adjusting the speed to the needs of each moment and minimizing engine consumption, thanks to the variable frequency controller.

It allows for operation with a large range of flows and external static pressures.

##### **Flexibility of installation**

The air entrance and exit grilles are interchangeable, thus increasing installation possibilities anywhere in the establishment.

##### **Improvement of seasonal efficiency**

Reduction of the annual cost of energy thanks to the high efficiency compressor, the reduction of the electricity consumption of the fan motor and the regulation of its control.

##### **Intelligent defrost control**

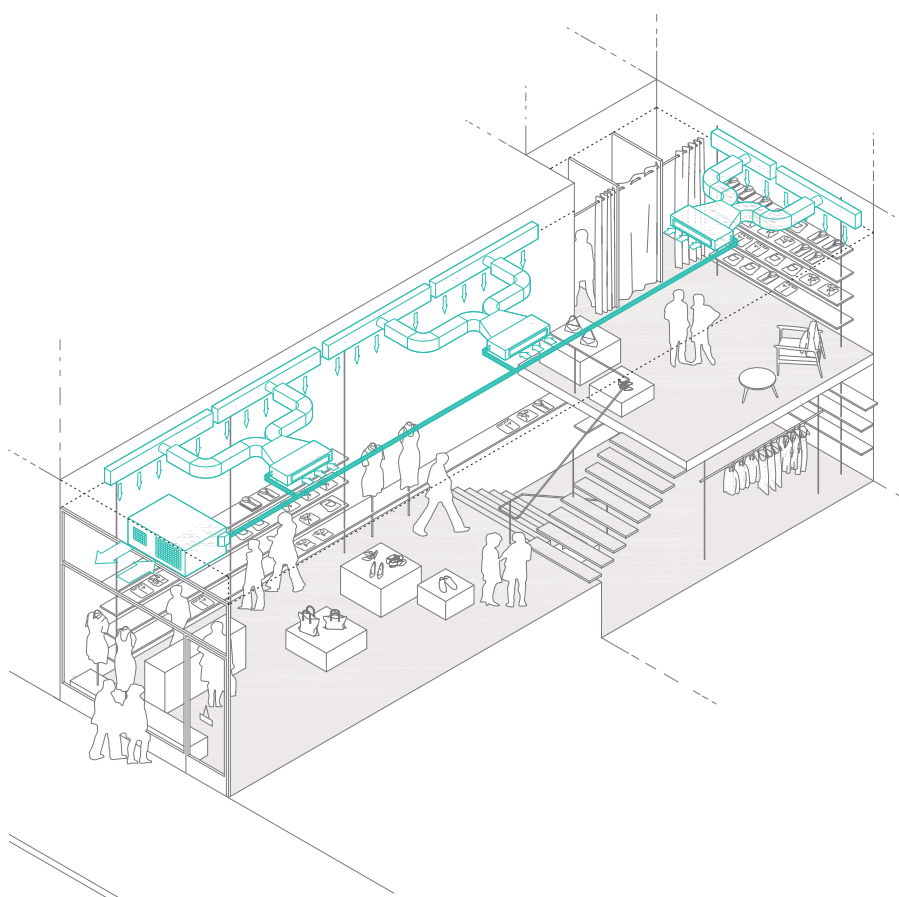

## CENTRIFUGAL VRF



OUTDOOR UNITS		RASC-4HNPE	RASC-5HNPE	RASC-6HNPE	RASC-8HNPE	RASC-10HNPE
Maximum number of connected units		5	5	5	6	6
Nominal power (min-max) <sup>(1)</sup>	Cooling kW	10.00	12.50	14.00	20.00	24.00
	Heating kW	11.20	14.00	15.50	22.40	26.00
Absorbed nominal power	Cooling kW	2.99	3.98	5.09	7.41	9.02
	Heating kW	2.95	4.12	5.74	7.00	8.52
EER - COP(2)		3.35 - 3.80	3.14 - 3.40	2.75 - 2.70	2.70 - 3.20	2.66 - 3.05
Sound pressure level (night mode) <sup>(3)</sup>		dB(A) 52 [48]	52 [48]	53 [49]	55 [51]	56 [52]
Airflow		m <sup>3</sup> /h 3300	3600		6900	
Power supply		3 N-400 V 50 Hz				
Pipe diameter (Liq - Gas)		inches 3/8 - 5/8			3/8 - 1	1/2 - 1
Maximum length		m 75			100	
Maximum height		m 30/20				
Refrigerant charge (maximum length of pipes without charge)		kg(m) 4.1 [30]	4.2 [30]		5.7 [30]	6.2 [30]
Independent control		Yes				
Refrigerant		R410A				
Color		Light gray / Dark gray				
Compressor		Scroll DC Inverter				
PRICE OF THE SET						

(1) The indicated cooling and heating capacity corresponds to the outdoor unit operating with indoor units at 100% capacity and is based on EN14511.  
 - Cooling: Indoor temperature 27°C DB; 19°C WB, outdoor temperature 35°C DB.  
 - Heating: Indoor temperature 20°C DB; outdoor temperature 7°C DB, 6°C WB. Pipe length: 7.5 m  
 (2) The supply of the indoor unit is not considered for the calculation of heating and cooling efficiencies.  
 (3) Measurement of the sound pressure is carried out in an anechoic camera at 1.5m below the unit (with duct) with its units operating at its nominal supply voltage.  
 (4) The seasonal efficiencies of RASC-4HNPE, according to EN14825 (2013), are: SEER=5.15; SCOP= 4.00. This model is within the scope of EcoDesign ErP Lot10.

Guaranteed performance

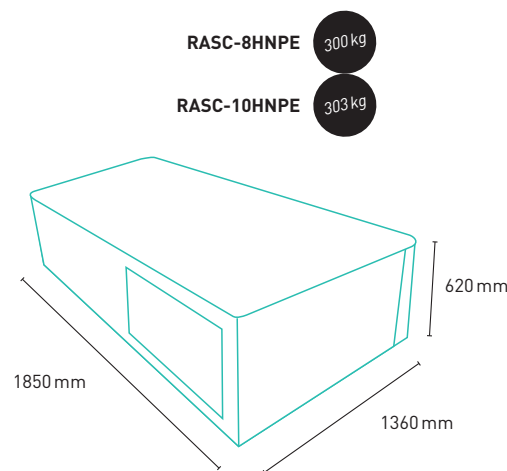
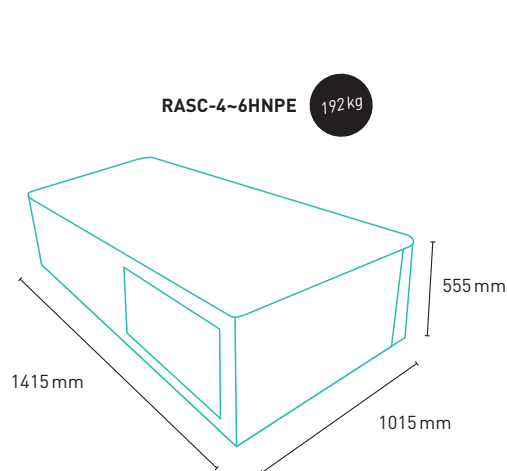
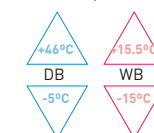

For more information about controls, see page 199.  
 Recommended prices - VAT not included, Waste Electrical and Electronic Equipment Directive (WEEE) fee not included.  
 To create the energy label visit our website [www.hitachiaircon.es](http://www.hitachiaircon.es) and use our Hitachi ErP AcTive Tool application.



**CENTRIFUGAL VRF  
COMBINATIONS**

**RASC-4~10HNPE**  
FLEXIBILITY IN THE COMBINATION OF INDOOR UNITS

The maximum number of indoor units that can be connected to the different models of the centrifugal VRF as well as its capacity index have been significantly improved compared to previous models. In addition, the range of combinations is much wider allowing for greater flexibility.

**COMBINATION TABLE**

COMBINATIONS	CAPACITY INDEX IN RELATION TO COMBINATIONS				
	OUTDOOR UNIT MODEL				
	RASC-4HNPE	RASC-5HNPE	RASC-6HNPE	RASC-8HNPE	RASC-10HNPE
Maximum number of connected indoor units	5			6	
Ratio of connected indoor units % (number of indoor units connected)	75~120% (≤ 4 units)			75~120% (≤ 4 units)	
	75~100% (5 units)			75~100% (5 or 6 units)	
Minimum indoor connectible unit	0.80 (≤ 4 units: unrestricted)			0.80 (≤ 4 units: unrestricted)	
	0.80 (5 units: restricted)			0.80 (5 or 6 units: restricted)	

**COMBINE INDOOR UNITS OF DIFFERENT TYPES AND DIFFERENT FEATURES THE WAY YOU LIKE**

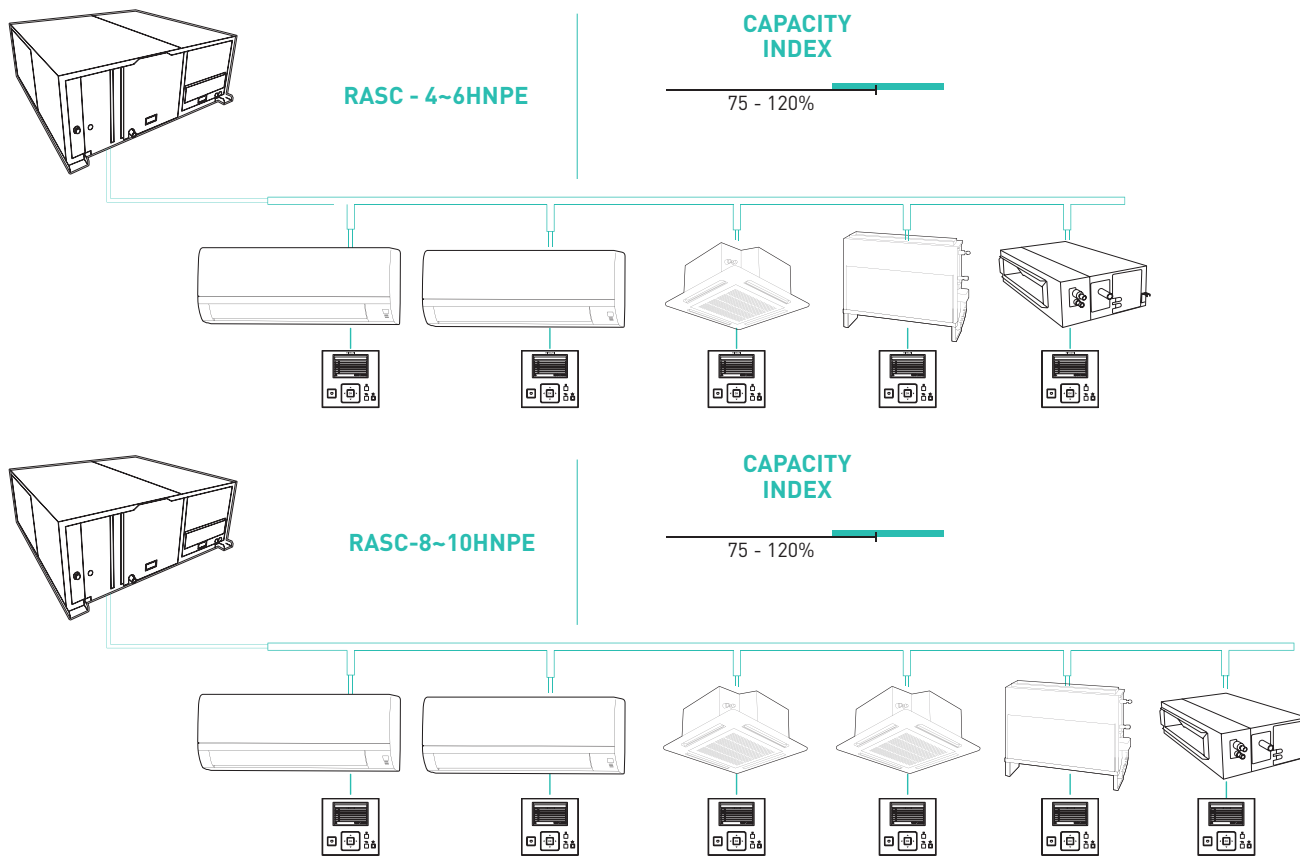



## MONO COMBINATIONS

### 1X1 CENTRIFUGAL VRF WALL MOUNTED

SET NAME	INDOOR UNIT	OUTDOOR UNIT	CONTROL	PRICE
CENTR. VRF. 4RPK.3M	RPK-4.0FSN3M	RASC-4HNPE	PC-ARFPE	

### 1X1 CENTRIFUGAL DUCT

SET NAME	INDOOR UNIT	OUTDOOR UNIT	CONTROL	PRICE
CENTR. VRF. 4RPI	RPI - 4.0FSN4E	RASC-4HNPE	PC-ARFPE	
CENTR. VRF. 5RPI	RPI - 5.0FSN4E	RASC-5HNPE	PC-ARFPE	
CENTR. VRF. 6RPI	RPI - 6.0FSN4E	RASC-6HNPE	PC-ARFPE	
CENTR. VRF. 8RPI	RPI - 8.0FSN4E	RASC-8HNPE	PC-ARFPE	
CENTR. VRF. 10RPI	RPI - 10.0FSN4E	RASC-10HNPE	PC-ARFPE	

### 1X1 CENTRIFUGAL VRF 2-WAY CASSETTE

SET NAME	INDOOR UNIT	OUTDOOR UNIT	CONTROL	PANEL	PRICE
CENTR. VRF. 4RCD	RCD-4FSN3	RASC-4HNPE	PC-ARFPE	P N23DNA	
CENTR. VRF. 5RCD	RCD-5FSN3	RASC-5HNPE	PC-ARFPE	P N23DNA	

### 1X1 CENTRIFUGAL VRF 4-WAY CASSETTE

SET NAME	INDOOR UNIT	OUTDOOR UNIT	PANEL	CONTROL	PRICE
CENTR. VRF. 4RCI	RCI - 4.0FSN4	RASC-4HNPE	P N23NA2	PC-ARFPE	
CENTR. VRF. 5RCI	RCI - 5.0FSN4	RASC-5HNPE	P N23NA2	PC-ARFPE	
CENTR. VRF. 6RCI	RCI - 6.0FSN4	RASC-6HNPE	P N23NA2	PC-ARFPE	

These examples of single combinations have been calculated with the PC-ARFPE control (not standard). For another control option, discount this and enter the price of the control chosen. For other types of combinations (up to 6 x 1) refer to pages 101-114 for the different System Free indoor units and page 192 for the different controls and accessories.

### 1X1 CENTRIFUGAL VRF CEILING

SET NAME	INDOOR UNIT	OUTDOOR UNIT	CONTROL	PRICE
CENTR. VRF. 4RPC.3E	RPC-4.0FSN3E	RASC-4HNPE	PC-ARFPE	
CENTR. VRF. 5RPC.3E	RPC-5.0FSN3E	RASC-5HNPE	PC-ARFPE	
CENTR. VRF. 6RPC.3E	RPC-6.0FSN3E	RASC-6HNPE	PC-ARFPE	
CENTR. VRF. 4RPC.3	RPC-4.0FSN3	RASC-4HNPE	PC-ARFPE	
CENTR. VRF. 5RPC.3	RPC-5.0FSN3	RASC-5HNPE	PC-ARFPE	
CENTR. VRF. 6RPC.3	RPC-6.0FSN3	RASC-6HNPE	PC-ARFPE	

For more information about controls, see page 199.  
Recommended prices - VAT not included, Waste Electrical and Electronic Equipment Directive (WEEE) fee not included.  
To create the energy label visit our website [www.hitachiircon.es](http://www.hitachiircon.es) and use our Hitachi ErP AcTive Tool application.

**STANDARD REFRIGERANT DISTRIBUTION COMBINATIONS**

**RASC-4~10HNPE**

**Mono Combination  
RAS-4~10HNPE**

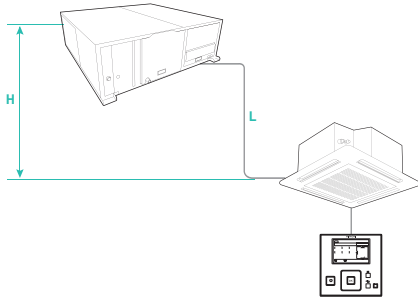

**TWIN Combination  
RAS-4~10HNPE**

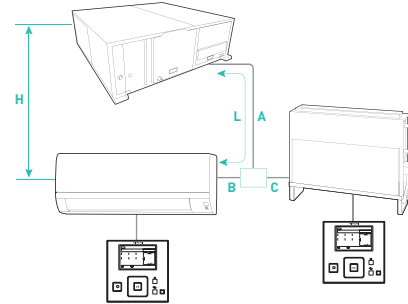

$L = A + \text{the longest of B and C}$

NOTE: L and H are the length and the height, respectively. In TWIN, TRI, QUADRI combinations, the length is the distance between the outdoor unit and the farthest indoor unit.

**TRI Combination  
RAS-4~10HNPE**

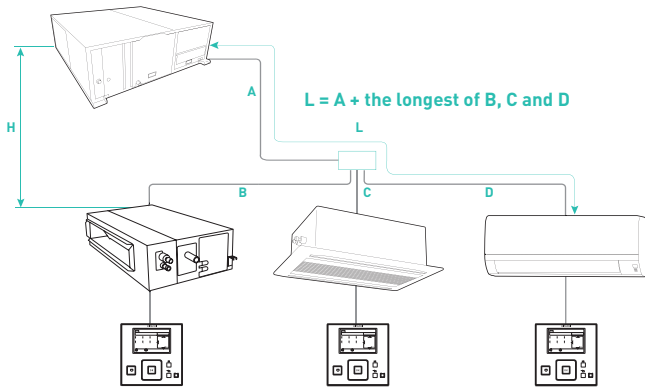

$L = A + \text{the longest of B, C and D}$

NOTE: L and H are the length and the height, respectively. In TWIN, TRI, and QUADRI combinations, the length is the distance between the outdoor unit and the farthest indoor unit.

**Combination QUADRI  
RAS-4~10HNPC (CASE A)**

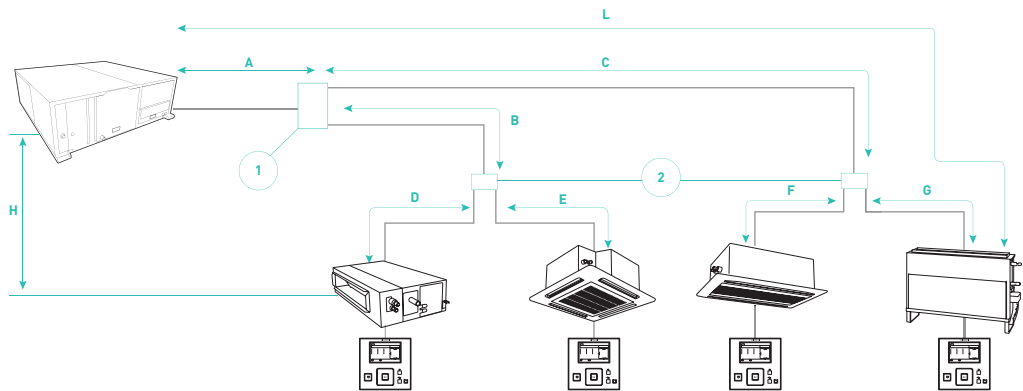

NOTE: L and H are the length and the height, respectively. In TWIN, TRI, QUADRI combinations, the length is the distance between the outdoor unit and the farthest indoor unit.

**Combination QUADRI  
RASC-8~10HNPe (CASE B)**

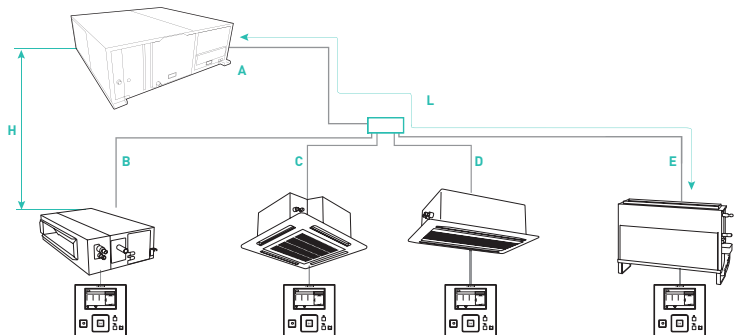

NOTE: L and H are the length and the height, respectively. In TWIN, TRI, and QUADRI combinations, the length is the distance between the outdoor unit and the farthest indoor unit.

### MAXIMUM LENGTH OF STANDARD INSTALLATION PIPE

		4HP	5HP	6HP	8HP	10HP
Maximum pipe length between the RASC unit and the farthest indoor unit.	Real pipe length		70			100
	Equivalent pipe length		90			125
Maximum height difference between the RASC unit and the indoor unit H	RASC unit higher than the indoor unit			30		
	Indoor unit higher than the RASC unit			20		
	The height difference between the units			3		
Maximum pipe length between the multi-kit and the indoor unit.	TWIN B, C		10			15
	TRI B, C, D	m	10			15
	QUADRI Case A: (A+B+C+D+E+F+G)		10			15
	Case B: (A+B+C+D+E)		0			15
Maximum pipe length between the multi-kit and the indoor unit.	TWIN (A+ B + C)		85		100	115
	TRI (A + B + C + D)		95		100	130
	QUADRI Case A: (A+B+C+D+E+F+G)		95		100	145
	Case B: (A+B+C+D+E)		-		100	145

Important note: The the refrigerant pipes length between the RASC unit and the first bifurcation must be greater than the length of the pipes between the first bifurcation and the farthest indoor unit. All the bifurcation pipes (B, C, D, E, F or G) must be balanced, and the difference between these sections cannot be greater than 8 m.

### DIAMETER OF THE MAIN BRANCH

INDOOR UNIT	PIPE SIZE	
	LIQUID	GAS
RASC-4HNPE	3/8"	5/8"
RASC-5HNPE	3/8"	5/8"
RASC-6HNPE	3/8"	5/8"
RASC-8HNPE	3/8"	1"
RASC-10HNPE	1/2"	1"

(1) RPI-8.0HP indoor unit is supplied with an adapter: Gas adapter: 3/4-1  
 (2) RPI-10.0HP indoor unit supplied with two adapters:  
 • Gas adapter: 7/8-1  
 • Liquid adapter: 3/8-1/2

### CONNECTION DIAMETER OF THE PIPES BETWEEN THE INDOOR UNIT AND THEIR MULTI-KIT

INDOOR UNIT	PIPE SIZE		MULTIKITS				
	LIQUID	GAS	OUTDOOR UNIT	TWIN	TRI	QUADRI CASE A	QUADRI CASE B (COLLECTOR)
0.8~1.5 HP	1/4"	1/2"	RASC-4HNPE				
1.8~2 HP	1/4"	5/8"	RASC-5HNPE	E-102SN4	E-102SN4 MH-84AN1 <sup>(2)</sup>	E-102SN4 <sup>(1)</sup>	-
2.30~6 HP	3/8"	5/8"	RASC-6HNPE				
8 HP	3/8"	3/4"	RASC-8HNPE	E-162SN4	E-162SN4 MH-84AN1 <sup>(2)</sup>	E-162SN4	MH-84AN1(2)
10 HP	3/8"	7/8"	RASC-10HNPE				

(1) If the pipe length is more than 70 m for 8 HP, use a liquid pipe of Ø12.70.  
 (2) If you use the MH84AN1 multi-kit (TRI combination figure) it is not necessary to use multikit 2.



## REFRIGERANT DISTRIBUTION IN LINE COMBINATIONS

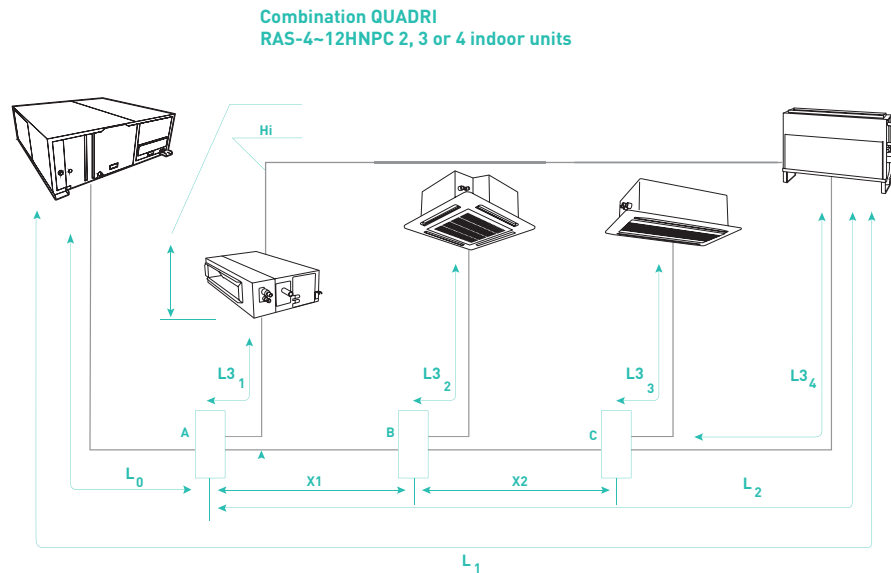

### MAXIMUM LENGTH OF REFRIGERANT PIPES (BRANCH PIPE INSTALLATIONS IN LINE)

		4HP	5HP	6HP	8HP	10HP
Maximum pipe length between the RASC unit and the farthest indoor unit (L)	Real pipe length		75		100	
	Equivalent pipe length		95		125	
Maximum length between the 1st Multi-kit and the farthest indoor unit (L2)			30		40	
Maximum pipe length (L3)			10		15	
Maximum height difference between the RASC unit and the indoor unit (H-O)	RASC unit higher than the indoor unit	m				
	Indoor unit higher than the RASC unit	30				
Maximum height difference between the indoor units (H)		20				
Maximum height difference between the indoor units (H)		10				
Maximum total pipe length (L1 + L3 <sub>1</sub> + L3 <sub>2</sub> + L3 <sub>3</sub> )			95		100	145

All the bifurcation pipes must be balanced, and the difference between these sections cannot be greater than 8m.

### CONNECTION DIAMETER OF THE PIPES BETWEEN THE INDOOR UNIT AND THEIR MULTI-KIT

INDOOR UNIT	PIPE SIZE		OUTDOOR UNIT	MULTIKIT
	LIQUID	GAS		
0.8~1.5 HP	1/4"	1/2"	RASC-4HNPE	E-102SN4
1.8~2 HP	1/4"	5/8"	RASC-5HNPE	
2.30~6 HP	3/8"	5/8"	RASC-6HNPE	
8 HP	3/8"	3/4"	RASC-8HNPE	E-162SN4
10 HP	3/8"	7/8"	RASC-10HNPE	

Note: For in-line TRI combinations, the second branch pipe is E102SN4

### MULTI-KIT PRICES

MULTI-KIT: SPLITTERS	PRICES
E-102SN4	
E-162SN4	
MH-84AN1	

For more information about controls, see page 199.  
Recommended prices - VAT not included, Waste Electrical and Electronic Equipment Directive (WEEE) fee not included.  
To create the energy label visit our website [www.hitachiircon.es](http://www.hitachiircon.es) and use our Hitachi ErP Active Tool application.

**Installation centrifugal VRF** in a bank branch at street level.

Installed in false ceiling, **hidden** in the facade.

Indoor units of **different typologies**, depending on the use of each space.

**Independent control** of each indoor unit for the comfort of different users.

The unit consumes in accordance with the demands of each space.

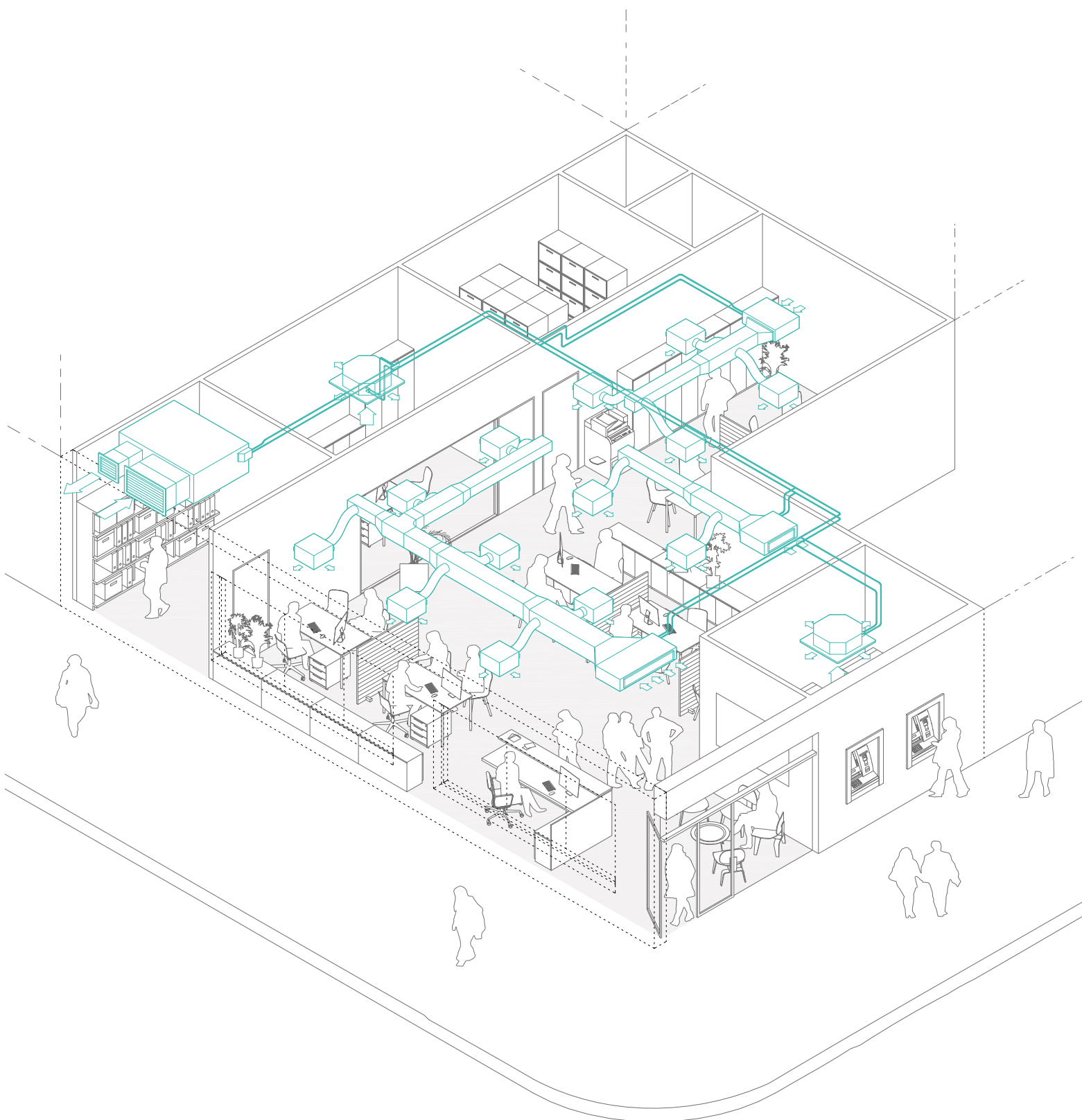

# UTOPIA IVX PREMIUM

**The most competitive air-conditioning solution for all types of business.** Maximum comfort ambiance so that customers feel comfortable and enjoy their experience.

**SEER of 7.88 (A++) and SCOP of 4.77 (A++).**

**Connectable indoor unit minimum capacity 0.8 HP.**

**Decrease in defrost time and increase in heating time.**

**INTELLIGENT DEFROST CONTROL**  
HEATING OPERATION WILL BE CONTINUOUSLY AVAILABLE FOR MORE TIME

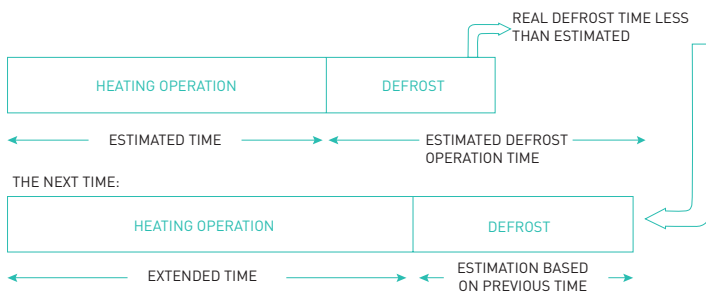

The 4-way valve does not require electricity consumption to maintain operation in heating mode, and can save up to 43%.



AIR CONDITIONING FOR  
**8 DIFFERENT SPACES**  
WITH **INDEPENDENT CONTROL**



**SMALLER MINI VRF**  
WITH 2 TO 3 HP MODELS,  
WITH A SUPERIOR HEIGHT



**MAXIMUM COOLING DISTANCE**  
EQUIVALENT TO UP TO 125 M

COMPLIES WITH EUROPEAN REGULATIONS **LOT.11 AND THE ERP.TIER 2 DIRECTIVE**

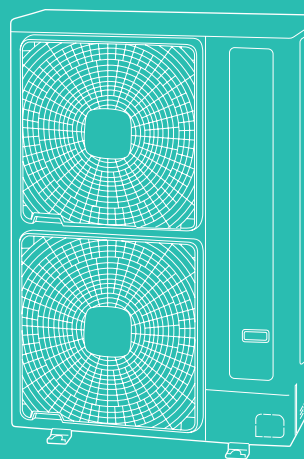

- Cools up to 8 different spaces
- Independent control
- Capacity index between 50% and 120%
- Compatible with all Hitachi control and management systems



More information about compatible controls and accessories [▶ Page 192](#)

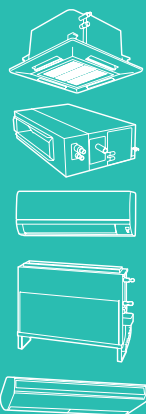

More information about compatible indoor units [▶ Page 96](#)

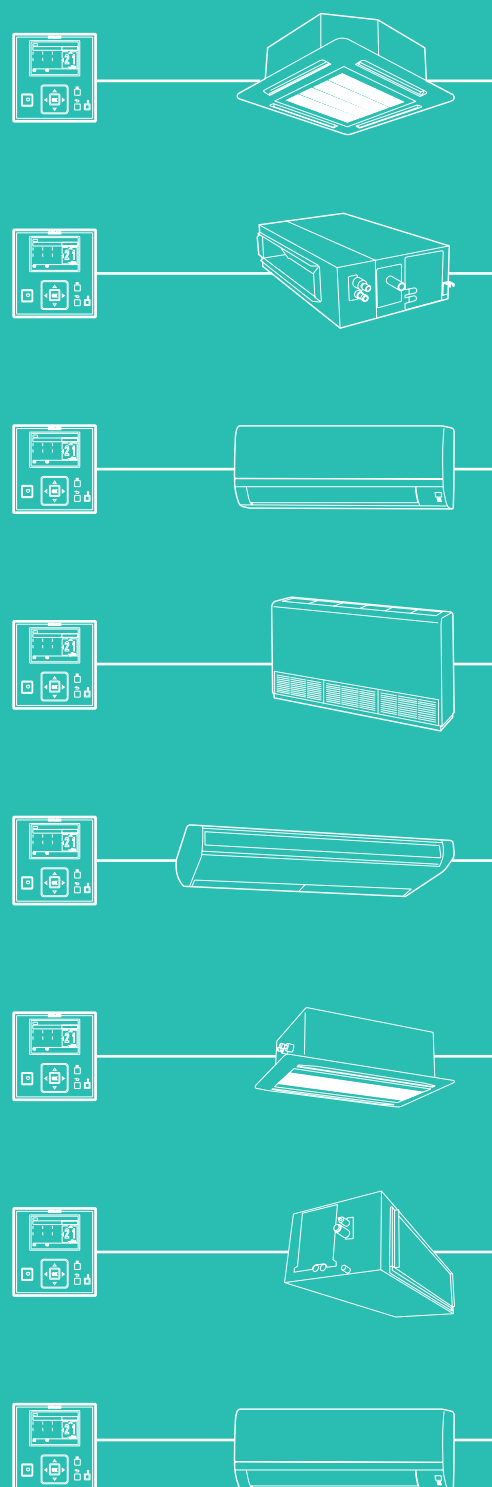

## OUTDOOR UNIT MULTI INVERTER

# UTOPIA IVX PREMIUM

COMBINATIONS | RAS-2~6H(V)NP1E / RAS-8~10HNPE



## CHARACTERISTICS

### Smallest Mini VRF on the market

It is the perfect option for air conditioning small and medium-sized businesses, with highly demanding requirements. It has higher height and does not overwhelm the facilities with its size.

### Flexibility

Compatible with System Free indoor units that are managed through all individual and centralized control systems, with option to H - Link II and CSNET WEB/MANAGER.

### Optional DX-KIT

Intended for the integration of air curtains and air treatment units when required.

### DC Inverter Compressor

Save on the electric bill for optimization at partial loads of up to 50%. Increased performance at low speed thanks to the transmission mechanism and engine refinement.

### Decrease in frost generation

It optimizes operation in heating mode to maintain the suitable temperature in each room.

### Air-condition up to 8 different spaces

Independent management of spaces, each with its own control.

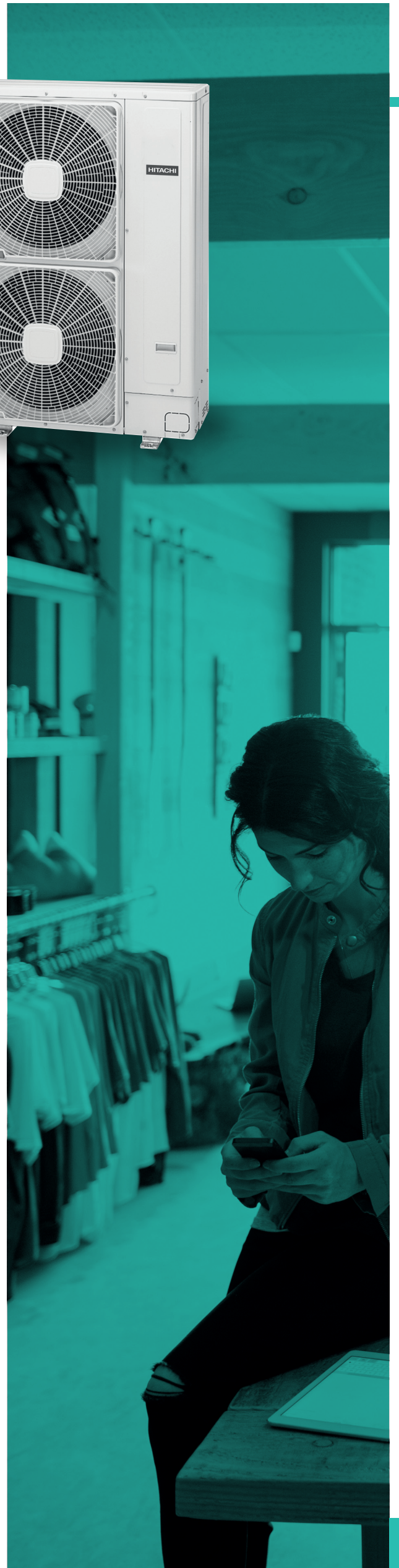
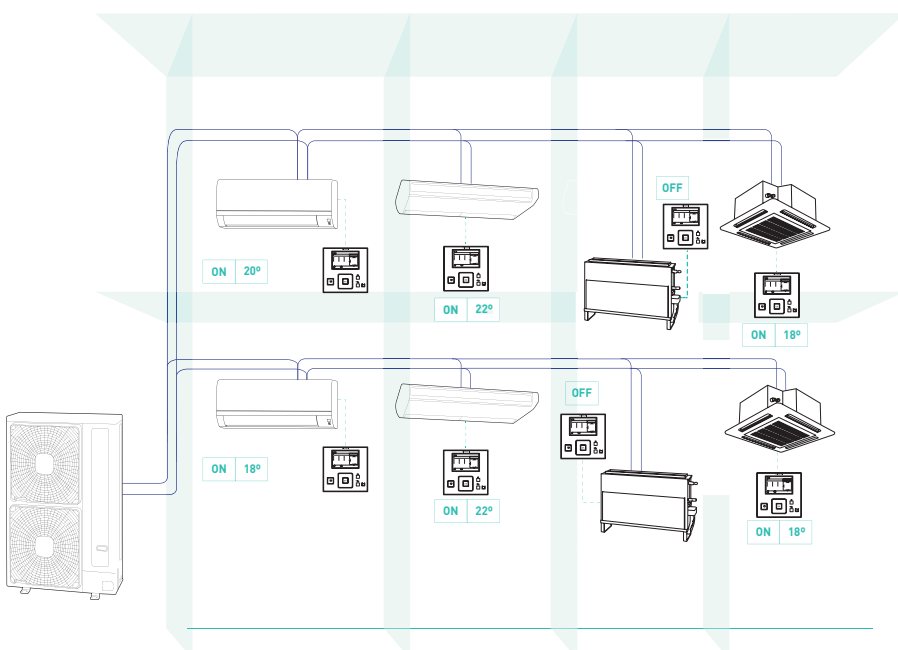





### UTOPIA IVX PREMIUM SINGLE PHASE

OUTDOOR UNITS	RAS-2HVNP1	RAS-2.5 HVNP1	RAS-3HVNP1E	RAS-4HVNP1E	RAS-5HVNP1E	RAS-6HVNP1E
Maximum number of connected units	2		3	5	6	
Nominal power absorbed (min-max) <sup>(1)</sup>	Cooling	5.00 (2.20~5.60)	5.60 (2.20~6.30)	7.10 (3.20~8.00)	10.00 (4.50~11.20)	14.00 (6.00~16.00)
	Heating	5.60 (2.20~7.10)	6.30 (2.20~8.00)	8.00 (3.50~10.60)	11.20 (5.00~14.00)	16.00 (5.00~20.00)
Absorbed nominal power	Cooling	1.17	1.20	1.46	1.99	3.94
	Heating	1.13	1.30	1.52	2.02	3.61
EER - COP <sup>(2)</sup>	More information, see page 159				3.81 - 4.55 (A/B)	3.41 - 4.23 (A/A)
Sound pressure level (night mode) <sup>(3)</sup>	44(42)	45(43)	46(42)	47(43)	48(44)	48(45)
Airflow	2436	2436	2700	4800	5400	6000
Power supply	1~230 V 50H					
Pipe diameter (Liq - Gas)	1/4 - 1/2		3/8 - 5/8			
Maximum length	50			75		
Maximum height	30/20					
Refrigerant charge (Maximum length of pipes without charge)	1.6 (30)		2.3 (30)	4.1 (30)	4.2 (30)	
Additional refrigerant charge	30		40	60		
Independent control	YES					
Refrigerant	R410A					
Compressor	SCROLL		Rotary	SCROLL		
<b>OUTDOOR UNIT PRICE</b>						

### UTOPIA IVX PREMIUM TRIPHASE

OUTDOOR UNITS	RAS-4HNP1E	RAS-5HNP1E	RAS-6HNP1E	RAS-8HNPE	RAS-10HNPE	RAS-12HNP	
Maximum number of connected units	5	6		8			
Nominal power absorbed (min-max) <sup>(1)</sup>	Cooling	10.00 (4.50~11.20)	12.50 (5.70~14.00)	14.00 (6.00~16.00)	20.00 (8.00~22.40)	25.00 (10.00~28.00)	30.00 (11.20~33.50)
	Heating	11.20 (5.00~14.00)	14.00 (5.00~18.00)	16.00 (5.00~20.00)	22.40 (6.30~28.00)	28.00 (8.00~35.00)	33.50 (9.00~37.50)
Absorbed nominal power	Cooling	1.99	3.11	3.94	5.36	7.88	11.05
	Heating	2.02	2.91	3.61	5.06	7.03	8.96
EER - COP <sup>(2)</sup>	4.68 - 5.16 (A/A)	3.81 - 4.55 (A/A)	3.41 - 4.23 (A/A)	3.56 - 4.21 (A/A)	3.07 - 3.84 (B/A)	2.65 - 3.64 (D/A)	
Sound pressure level (night mode) <sup>(3)</sup>	47 (43)	48 (44)	48 (45)	57 (55)	58 (56)	59 (57)	
Airflow	4800	5400	6000	7620	8040	9780	
Power supply	3 N~400 V 50 Hz						
Pipe diameter (Liq - Gas)	3/8 - 5/8		3/8 - 1		1/2 - 1		
Maximum length	75		it must be calculated				
Maximum height	30/20						
Refrigerant charge (Maximum length of pipes without charge)	4.1 (30)	4.2 (30)		5.7 (30)	6.2 (30)	6.7 (30)	
Additional refrigerant charge	60		100				
Independent control	YES						
Refrigerant	R410A						
Compressor	SCROLL						
<b>OUTDOOR UNIT PRICE</b>							

\* For systems with two indoor units, the additional refrigerant charge required is 24 g/m.  
 (1) The nominal cooling and heating capacity is the combined capacity of the RAS system and is based on EN14511  
 - Cooling: Indoor temperature 27°C DB; outdoor temperature 35°C DB.  
 - Heating: Indoor temperature 20°C DB; outdoor temperature 7°C DB, 6°C WB. Pipe length: 7.5m  
 (2) SEER and SCOP conform to the EN 14825 regulation.  
 The SEER, SCOP, EER and COP are specified on the outdoor unit in combination with the indoor unit mentioned.  
 COP and EER data are specified for RCI-FSN4 indoor unit combination.  
 (3) The sound pressure level has been measured in an anechoic camera at 1.5m from ground level and 1m from the front of the unit (Units operating at their nominal supply voltage).

Guaranteed performance

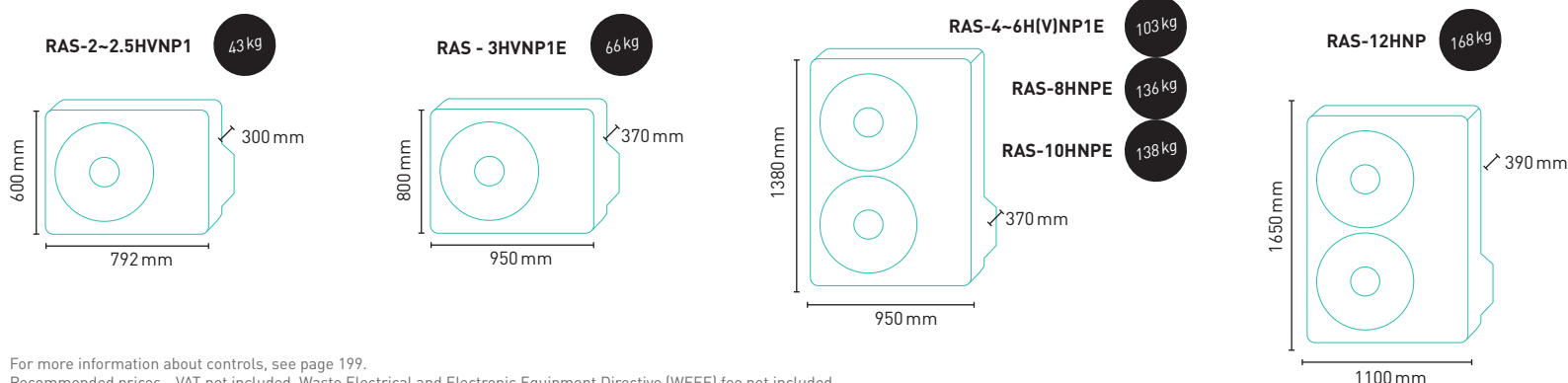
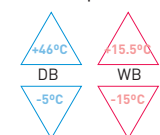

For more information about controls, see page 199.  
 Recommended prices - VAT not included, Waste Electrical and Electronic Equipment Directive (WEEE) fee not included.  
 To create the energy label visit our website [www.hitachiircon.es](http://www.hitachiircon.es) and use our Hitachi ErP AcTive Tool application.



## OUTDOOR UNIT MULTI INVERTER

# UTOPIA IVX PREMIUM

COMBINATIONS | RAS-2~6H(V)NP1E / RAS-8~10HNPE

### SEASONAL PERFORMANCE IN COOLING AND HEATING

COMBINATIONS		COOLING			HEATING		
OUTDOOR UNIT	INDOOR UNIT	SEER	ENERGY CLASS	DESIGN P (35°C) kW	SCOP	ENERGY CLASS	DESIGN P (10°C) kW
RAS-2HVNP1	RCI-2,0FSN4	6.49	A++	5.00	4.67	A++	5.00
	RPC-2,0FSN3	5.63	A+	5.00	4.44	A+	5.00
	RPC-2,0FSN3E	5.05	B	5.00	3.8	A	5.00
	RPI-2,0FSN4E	5.6	A+	5.00	4.01	A+	5.00
	RPK-2,0FSN3M	5.47	A	5.00	4.01	A+	5.00
RAS-2,5HVNP1	RCI-2,5FSN4	6.05	A+	5.60	4.77	A++	5.20
	RPC-2,5FSN3	5.49	A	5.60	4.49	A+	5.20
	RPC-2,5FSN3E	4.66	B	5.60	3.8	A	5.20
	RPI-2,5FSN4E	5.51	A	5.60	4.33	A+	5.20
	RPK-2,5FSN3M	5.24	A	5.60	4.14	A+	5.20
RAS-3HVNP1E	RCI-3,0FSN4	7.42	A++	7.10	4.37	A+	6.40
	RPC-3,0FSN3	5.87	A+	7.10	4.00	A+	6.00
	RPC-3,0FSN3E	5.33	A	7.10	3.80	A	6.00
	RPI-3,0FSN4E	6.05	A+	7.10	4.00	A+	6.00
	RPK-3,0FSN3M	6.4	A++	7.10	3.91	A	6.00
RAS-4HVNP1E	RCI-4,0FSN4	7.88	A++	10.00	4.68	A++	11.50
	RPC-4,0FSN4	6.53	A++	10.00	4.23	A+	11.50
	RPC-4,0FSN3E	5.92	A+	10.00	3.81	A	11.20
	RPI-4,0FSN4E	7.21	A++	10.00	4.23	A+	11.50
	RPK-4,0FSN3M	6.81	A++	10.00	3.81	A	9.00
RAS-4HNP1E	RCI-4,0FSN4	7.66	A++	10.00	4.68	A++	11.50
	RPC-4,0FSN4	6.38	A++	10.00	4.23	A+	11.50
	RPC-4,0FSN3E	5.8	A+	10.00	3.81	A	11.20
	RPI-4,0FSN4E	6.3	A++	10.00	4.23	A+	11.50
	RPK-4,0FSN3M	6.64	A++	10.00	3.81	A	9.00

Igeretxe Hotel, Vizcaya  
Utopia IVX Premium  
More info: [www.hitachiaircon.es](http://www.hitachiaircon.es)



## MONO COMBINATIONS

### 1X1 UTOPIA IVX PREMIUM WALL MOUNTED

SET NAME	INDOOR UNIT	OUTDOOR UNIT	CONTROL	TOTAL PRICE
UTP.RPK2.IVX.V.PM1.3M	RPK-2.0FSN3M	RAS - 2HVNP1	PC-ARFPE	
UTP.RPK2,5.IVX.V.PM1.3M	RPK-2.5FSN3M	RAS - 2.5HVNP1	PC-ARFPE	
UTP.RPK3.IVX.V.PM1.3M	RPK-3.0FSN3M	RAS - 3HVNP1E	PC-ARFPE	
UTP.RPK4.IVX.V.PM1.3M	RPK-4.0FSN3M	RAS - 4HVNP1E	PC-ARFPE	
UTP.RPK4.IVX.PM1.3M	RPK-4.0FSN3M	RAS - 4HNP1E	PC-ARFPE	

### 1X1 UTOPIA IVX PREMIUM DUCT

SET NAME	INDOOR UNIT	OUTDOOR UNIT	CONTROL	TOTAL PRICE
UTP.RPI2.IVX.V.PM1.4E	RPI - 2.0FSN4E	RAS - 2HVNP1	PC-ARFPE	
UTP.RPI2,5.IVX.V.PM1.4E	RPI - 2.5FSN4E	RAS - 2.5HVNP1	PC-ARFPE	
UTP.RPI3.IVX.V.PM1.4E	RPI - 3.0FSN4E	RAS - 3HVNP1E	PC-ARFPE	
UTP.RPI4.IVX.V.PM1.4E	RPI - 4.0FSN4E	RAS - 4HVNP1E	PC-ARFPE	
UTP.RPI4.IVX.PM1.4E	RPI - 4.0FSN4E	RAS - 4HNP1E	PC-ARFPE	
UTP.RPI5.IVX.V.PM1.4E	RPI - 5.0FSN4E	RAS - 5HVNP1E	PC-ARFPE	
UTP.RPI5.IVX.PM1.4E	RPI - 5.0FSN4E	RAS - 5HNP1E	PC-ARFPE	
UTP.RPI6.IVX.PM1.V.4E	RPI - 6.0FSN4E	RAS - 6HVNP1E	PC-ARFPE	
UTP.RPI6.IVX.PM1.4E	RPI - 6.0FSN4E	RAS - 6HNP1E	PC-ARFPE	
UTP.RPI8.IVX.PM1.3E	RPI - 8.0FSN3E	RAS - 8HNPE	PC-ARFPE	
UTP.RPI10.IVX.PM1.3E	RPI - 10.0FSN3E	RAS - 10HNPE	PC-ARFPE	

### 1X1 UTOPIA IVX PREMIUM CEILING

SET NAME	INDOOR UNIT	OUTDOOR UNIT	CONTROL	TOTAL PRICE
UTP.RPC3.IVX.V.PM1.3E	RPC-3.0FSN3E	RAS - 3HVNP1E	PC-ARFPE	
UTP.RPC4.IVX.V.PM1.3E	RPC-4.0FSN3E	RAS - 4HVNP1E	PC-ARFPE	
UTP.RPC4.IVX.PM1.3E	RPC-4.0FSN3E	RAS - 4HNP1E	PC-ARFPE	
UTP.RPC5.IVX.V.PM1.3E	RPC-5.0FSN3E	RAS - 5HVNP1E	PC-ARFPE	
UTP.RPC5.IVX.PM1.3E	RPC-5.0FSN3E	RAS - 5HNP1E	PC-ARFPE	
UTP.RPC6.IVX.V.PM1.3E	RPC-6.0FSN3E	RAS - 6HVNP1E	PC-ARFPE	
UTP.RPC6.IVX.PM1.3E	RPC-6.0FSN3E	RAS - 6HNP1E	PC-ARFPE	
UTP.RPC2.IVX.V.PM1.3	RPC-2.0FSN3	RAS - 2HVNP1	PC-ARFPE	
UTP.RPC2,5.IVX.V.PM1.3	RPC-2.5FSN3	RAS - 2.5HVNP1	PC-ARFPE	
UTP.RPC3.IVX.V.PM1.3	RPC-3.0FSN3	RAS - 3HVNP1E	PC-ARFPE	
UTP.RPC4.IVX.V.PM1.3	RPC-4.0FSN3	RAS - 4HVNP1E	PC-ARFPE	
UTP.RPC4.IVX.PM1.3	RPC-4.0FSN3	RAS - 4HNP1E	PC-ARFPE	
UTP.RPC5.IVX.V.PM1.3	RPC-5.0FSN3	RAS - 5HVNP1E	PC-ARFPE	
UTP.RPC5.IVX.PM1.3	RPC-5.0FSN3	RAS - 5HNP1E	PC-ARFPE	
UTP.RPC6.IVX.V.PM1.3	RPC-6.0FSN3	RAS - 6HVNP1E	PC-ARFPE	
UTP.RPC6.IVX.PM1.3	RPC-6.0FSN3	RAS - 6HNP1E	PC-ARFPE	



### 1X1 UTOPIA IVX PREMIUM 2-WAY CASSETTE

SET NAME	INDOOR UNIT	OUTDOOR UNIT	CONTROL	PANEL	TOTAL PRICE
UTP.RCD2.IVX.V.PM1.2	RCD-2.0FSN3	RAS - 2HVNP1	PC-ARFPE	P N23DNA	
UTP.RCD2,5.IVX.V.PM1.2	RCD-2.5FSN3	RAS - 2.5HVNP1	PC-ARFPE	P N23DNA	
UTP.RCD3.IVX.V.PM1.2	RCD-3.0FSN3	RAS - 3HVNP1E	PC-ARFPE	P N23DNA	
UTP.RCD4.IVX.V.PM1.2	RCD-4.0FSN3	RAS - 4HVNP1E	PC-ARFPE	P N23DNA	
UTP.RCD4.IVX.PM1.2	RCD-4.0FSN3	RAS - 4HNP1E	PC-ARFPE	P N23DNA	
UTP.RCD5.IVX.V.PM1.2	RCD-5.0FSN3	RAS - 5HVNP1E	PC-ARFPE	P N23DNA	
UTP.RCD5.IVX.PM1.2	RCD-5.0FSN3	RAS - 5HNP1E	PC-ARFPE	P N23DNA	

### 1X1 UTOPIA IVX PREMIUM 800X800 4-WAY CASSETTE

Set name	Indoor Unit	Outdoor Unit	Control	Panel	Total price
UTP.RCI2.IVX.V.PM1.4	RCI - 2.0FSN4	RAS - 2HVNP1	PC-ARFPE	P N23NA2	
UTP.RCI2,5.IVX.V.PM1.4	RCI - 2.5FSN4	RAS - 2.5HVNP1	PC-ARFPE	P N23NA2	
UTP.RCI3.IVX.V.PM1.4	RCI - 3.0FSN4	RAS - 3HVNP1E	PC-ARFPE	P N23NA2	
UTP.RCI4.IVX.V.PM1.4	RCI - 4.0FSN4	RAS - 4HVNP1E	PC-ARFPE	P N23NA2	
UTP.RCI4.IVX.PM1.4	RCI - 4.0FSN4	RAS - 4HNP1E	PC-ARFPE	P N23NA2	
UTP.RCI5.IVX.V.PM1.4	RCI - 5.0FSN4	RAS - 5HVNP1E	PC-ARFPE	P N23NA2	
UTP.RCI5.IVX.PM1.4	RCI - 5.0FSN4	RAS - 5HNP1E	PC-ARFPE	P N23NA2	
UTP.RCI6.IVX.V.PM1.4	RCI - 6.0FSN4	RAS - 6HVNP1E	PC-ARFPE	P N23NA2	
UTP.RCI6.IVX.PM1.4	RCI - 6.0FSN4	RAS - 6HNP1E	PC-ARFPE	P N23NA2	

Recommended prices - VAT not included, Waste Electrical and Electronic Equipment Directive (WEEE) fee not included.  
To create the energy label visit our website [www.hitachiircon.es](http://www.hitachiircon.es) and use our Hitachi ErP Active Tool application.

**OUTDOOR UNIT**  
MULTI INVERTER

**UTOPIA IVX PREMIUM**  
COMBINATIONS | RAS-2~6H(V)NP1E / RAS-8~10HNPE

**COMBINATION TABLE RAS-2~12H(V)NP(1)(E)**

**CAPACITY INDEX**

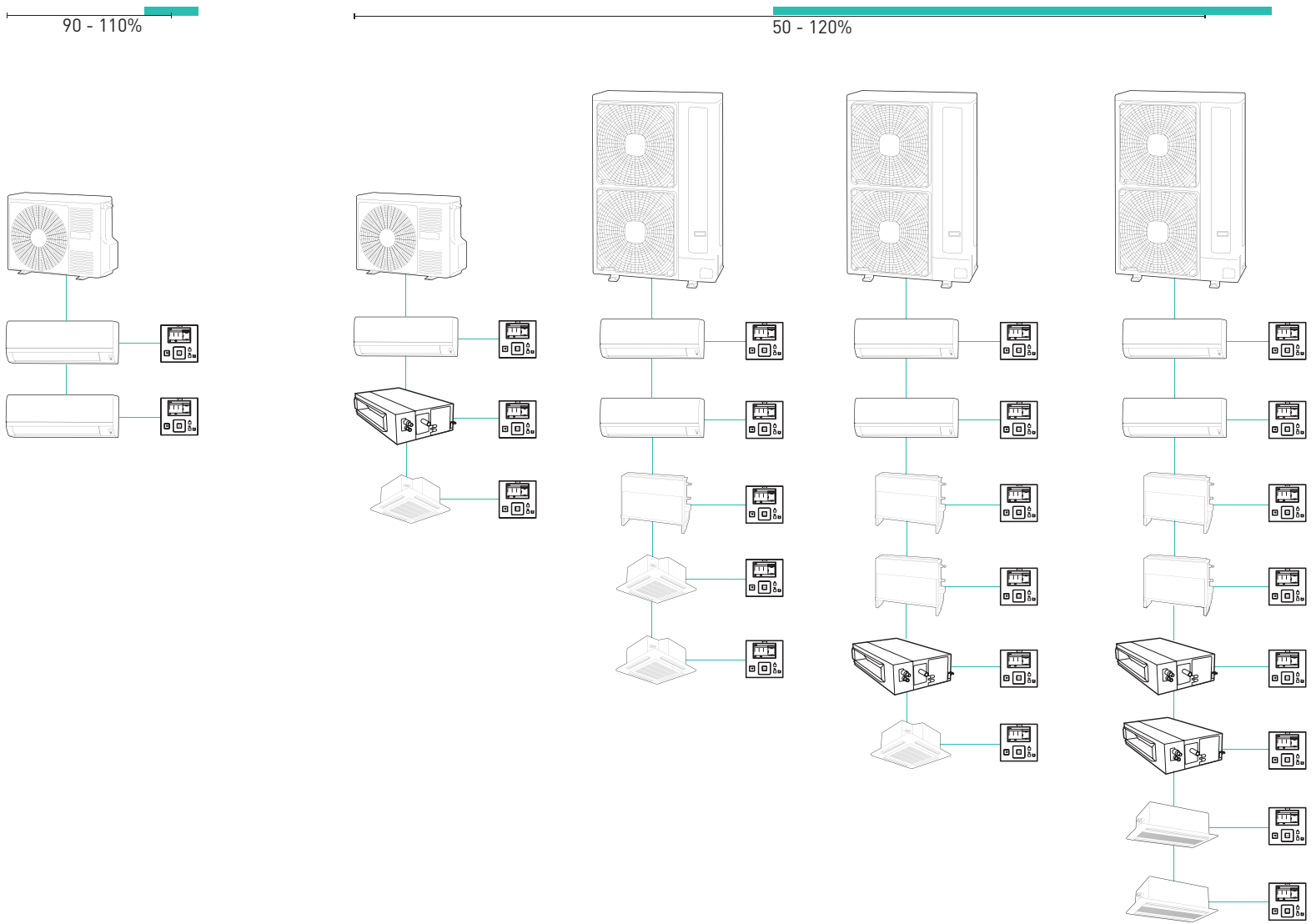

## CAPACITY INDEX IN RELATION TO COMBINATIONS

OUTDOOR UNIT	RAS-2HVNP1 <sup>(2)</sup>	RAS-2.5 HVNP <sup>(3)</sup>	RAS-3HVNP1E	RAS-4H(V)NP1E	RAS-5H(V)NP1E	RAS-6H(V)NP1E
Maximum number of connected indoor units	2		3	5	6	
Ratio of connected indoor units % (number of indoor units connected)	90~100% (1 unit)		50~120% (≤ 2units)	50~120% (≤ 4 units)		
	90~100% (2 units) <sup>(1)</sup>		50~100% (3 units)	50~100% (5 units) <sup>(1)</sup>	50~100% (5 or 6 units) <sup>(1)</sup>	
Connectable indoor unit minimum capacity (HP)	0.8					

OUTDOOR UNIT	RAS - 8HNPE	RAS - 10HNPE	RAS - 12HNP
Maximum number of connected indoor units	8		
Ratio of connected indoor units % (number of indoor units connected)	50~120% (≤ 4 units)		
	50~100% (5, 6, 7 or 8 units)		
Connectable indoor unit minimum capacity (HP)	0.8		

(1) Follow Table 1 (see instructions) to optimize indoor unit balance.  
 (2) When installing RCI-FSN4 indoor unit, only the 1x1 combination is allowed.  
 (3) When installing certain units and RCI-FSN4 is present, the minimum allowed capacity for these series is 1.5 HP.

## MULTI-KIT PRICES: UTOPIA IXV PREMIUM SPLITTERS

OUTDOOR UNIT	MULTI-KIT		
	TWIN	TRI	QUADRI
RAS-2HVNP1	E-102SN4	-	-
RAS-2.5 HVNP1		-	-
RAS-3HVNP1E		E-102SN4	-
RAS-4H(V)NP1E		E-102SN4 MH-84AN1 <sup>(2)</sup>	E-102SN4
RAS-5H(V)NP1E			
RAS-6H(V)NP1E			
RAS-8HNPE	E-162SN4	E-162SN4 MH-84AN1 <sup>(2)</sup>	E-162SN4 MH-84AN1 <sup>(2)</sup>
RAS-10HNPE			
RAS-12HNPE			

(1) If the pipe length (A+B or A+C or A+D) exceeds 70 m in 8 HP units, use a Ø12.70 liquid pipe.  
 (2) If you use the MH84AN1 multi-kit (TRI combination figure) it is not necessary to use multikit 2.  
 Note: For in-line TRI combinations, the second branch pipe is E102SN4

MULTI-KIT: SPLITTERS	PRICES
E-102SN4	
E-162SN4	
MH-84AN1	

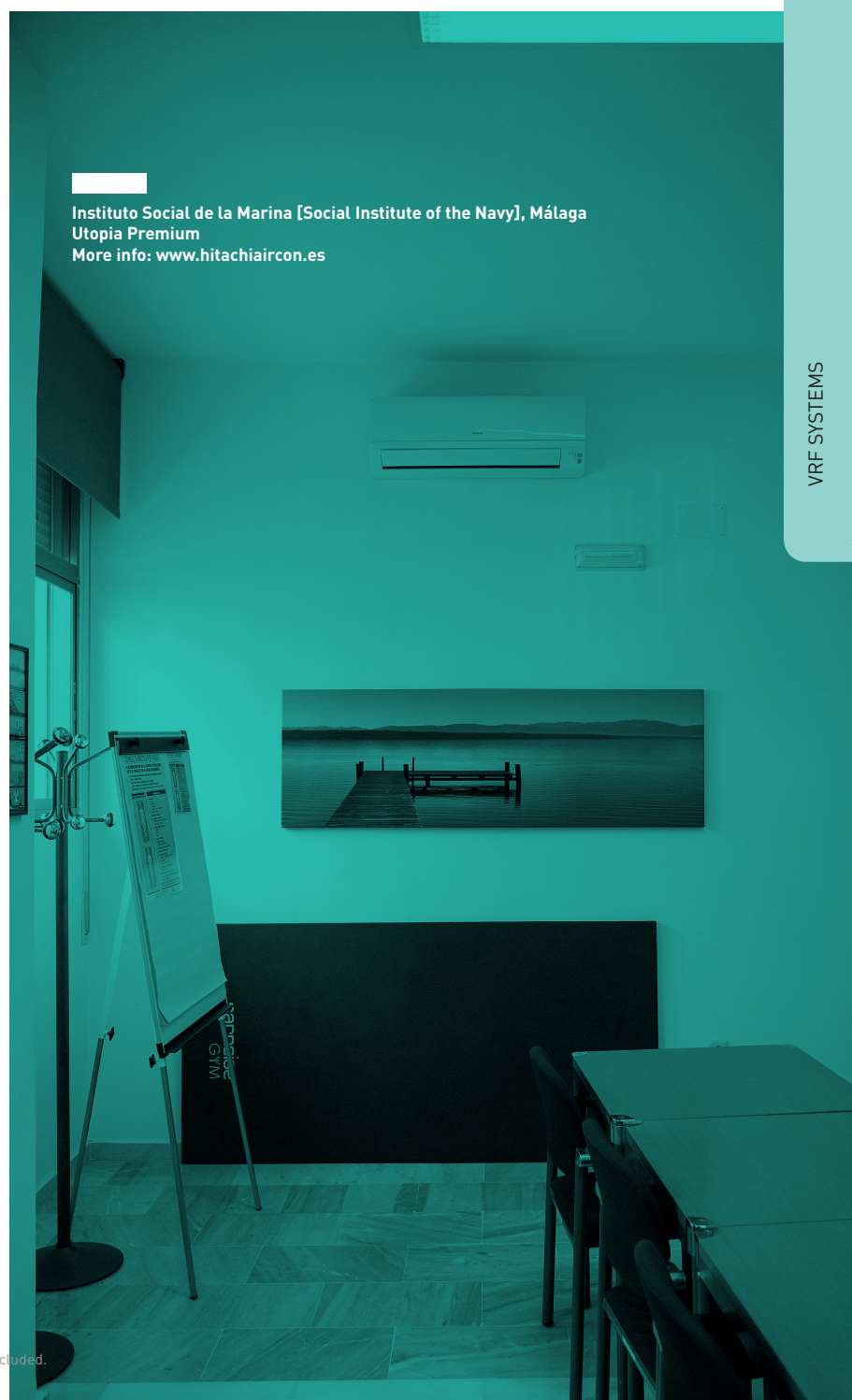

VRF SYSTEMS

For more information about controls, see page 199.  
 Recommended prices - VAT not included, Waste Electrical and Electronic Equipment Directive (WEEE) fee not included.  
 To create the energy label visit our website [www.hitachiircon.es](http://www.hitachiircon.es) and use our Hitachi ErP AcTive Tool application.



# MINI VRF



Watch the video



**Because of its compact design, its installation is even easier** even in the most demanding places.

Capable of working with outdoor temperatures **up to  $-20^{\circ}\text{C}$  in heating mode** and **up to  $46^{\circ}\text{C}$  in cooling mode**.

**It controls the climate of all kinds of establishments without needing to install the outdoor unit on the roof.** Thanks to its size, it even fits on a terrace.

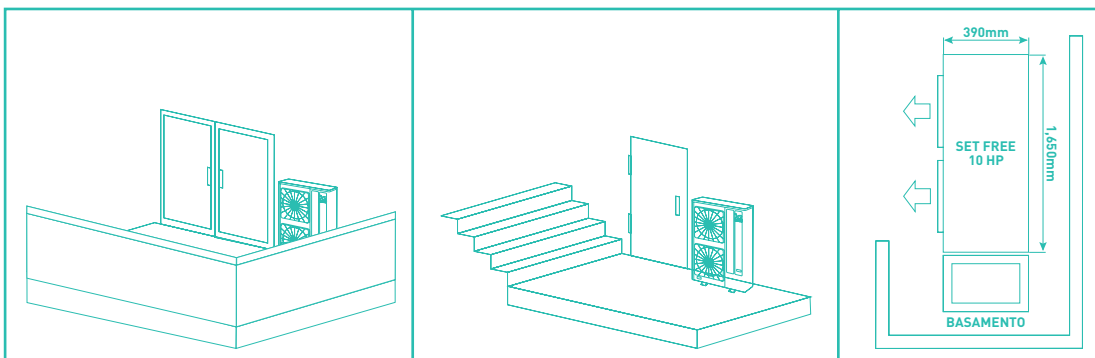

The 3-blade fan makes it **the quietest unit on the market**, with noise reduction of up to 4 dB(A). This way, it does not bother the neighbors.

**FS(V)N(Y)3E 4 to 6 HP** for facilities of up to 15500 kW.  
**FSNM 8 to 12 HP** for facilities of up to 33500 kW.

**EER-COP: 6.56-4.24\***

**Compatible** with all Hitachi control and management systems.

\*Depending on model



More information  
about compatible  
controls and  
accessories

▶ Page 192

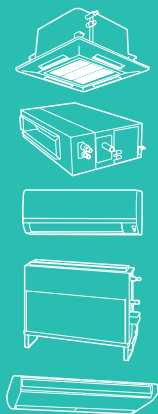

More  
information  
about  
compatible  
indoor units

▶ Page 96



EASY INSTALLATION  
WITHOUT USING THE  
ROOF: **30% MORE  
COMPACT**

AIR CONDITIONING FOR  
**12 DIFFERENT SPACES**  
WITH **INDEPENDENT  
CONTROL**

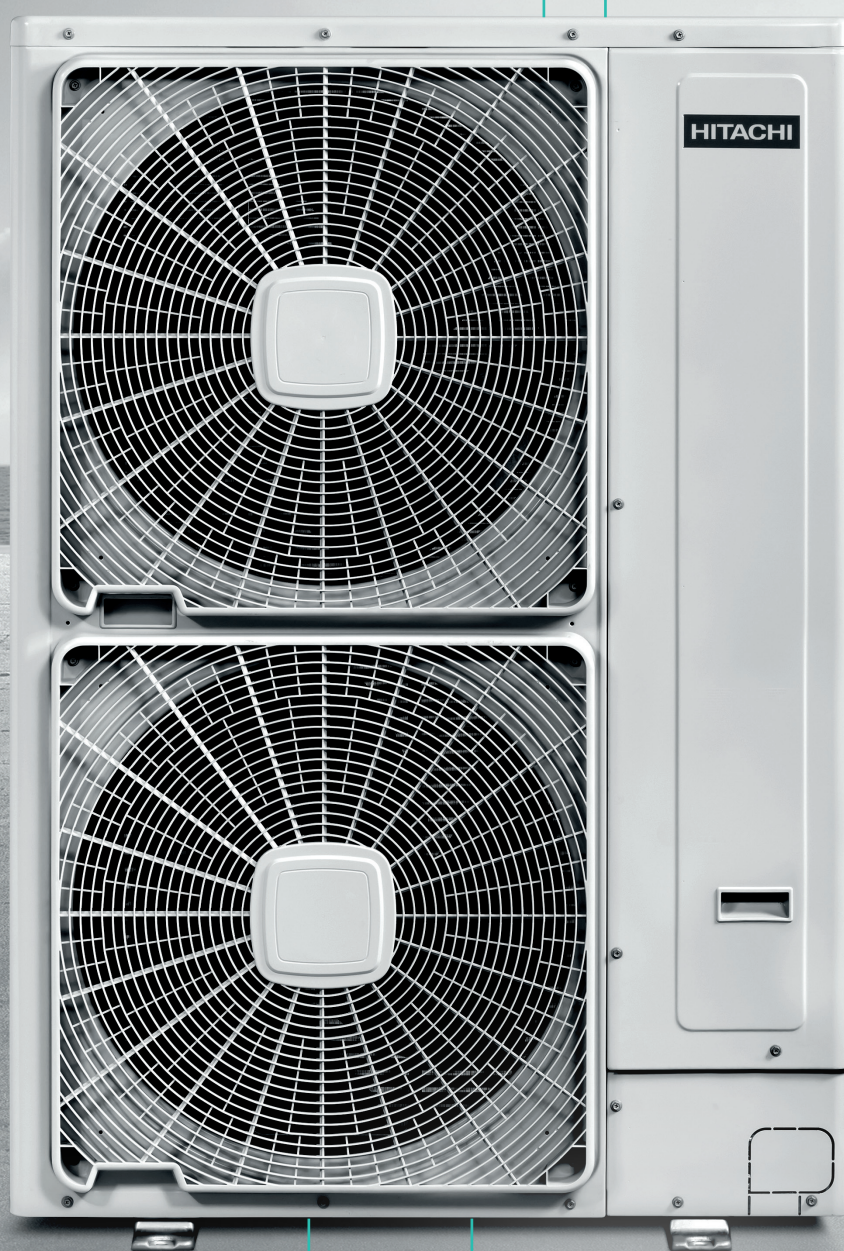

**ACTUAL PIPE LENGTH**  
75~100\*

**LIMITATION OF  
ELECTRICITY  
CONSUMPTION,**  
REGULATING BETWEEN  
100%, 70% AND 50% OF  
THE NOMINAL VALUE



## OUTDOOR UNIT SET FREE MINI

# FSVN3E / FSNY3E

RAS-4~6FSVN3E / RAS-4~6FSNY3E



### CHARACTERISTICS

#### Scroll DC Inverter Compressor

More efficiency at partial loads and at low speed.

#### "Side Flow" Technology

The fan speed is distributed evenly thanks to this technology.

#### Flexibility

Compatible with all System Free indoor units and individual and/or centralized management systems.

#### Automatic control of electricity consumption

It can be adjusted between 100%, 70% and 50% of the nominal value.

#### Wider operating range

From -5°C to 46°C in cooling and from -20°C to 15°C in heating.

#### Very high flow fan

More aerodynamic than previous models. It has a larger surface in contact with the air and a better angle of rotation, which prevents turbulence and allows the installation of the fan at a lower level.

AUTOMATIC CONTROL OF ENERGY CONSUMPTION.  
THIS FUNCTION MAINTAINS THE ADJUSTED CURRENT VALUE.

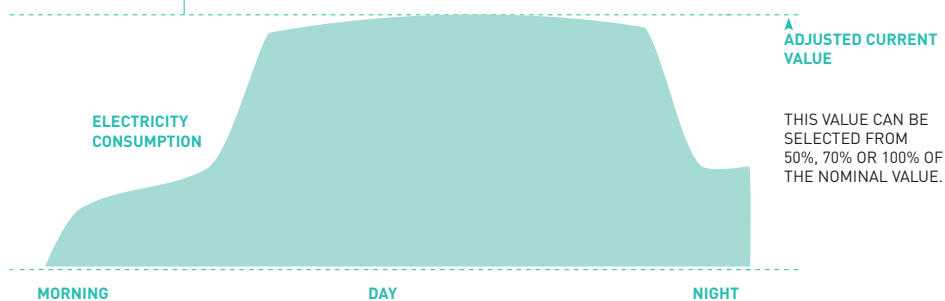

THIS VALUE CAN BE  
SELECTED FROM  
50%, 70% OR 100% OF  
THE NOMINAL VALUE.

*Automatic consumption control*



## FSVN3E / FSNY3E



OUTDOOR UNITS	SINGLE PHASE			THREE-PHASE		
	RAS - 4FSVN3E	RAS - 5FSVN3E	RAS - 6FSVN3E	RAS - 4FSNY3E	RAS - 5FSNY3E	RAS - 6FSNY3E
Maximum number of units Connectible	6 (8)*	8 (10)*	9 (12)*	6 (8)*	8 (10)*	9 (12)*
Nominal power (min-max) <sup>(1)</sup>	Cooling kW	11.20 (5.60~11.20)	14.00 (7.00~14.00)	15.50 (7.80~15.50)	11.20 (5.60~11.20)	14.00 (7.00~14.00)
	Heating kW	12.50 (6.30~12.50)	16.00 (8.00~16.00)	18.00 (9.00~18.00)	12.50 (6.30~12.50)	16.00 (8.00~16.00)
Absorbed nominal power (min-max)	Cooling kW	2.75	3.88	4.67	2.72	3.84
	Heating kW	3.03	4.20	4.90	3.00	4.16
EER - COP		4.07 - 4.13	3.61 - 3.81	3.32 - 3.67	4.12 - 4.17	3.65 - 3.85
Sound Pressure Level (very low - low- medium - high) <sup>(2)</sup>	Cooling dB(A)	49 (45)	51 (47)	51 (48)	49 (45)	51 (47)
	Heating dB(A)	51	53		51	53
Airflow m <sup>3</sup> /h	5400		6000	5400		6000
Power supply	230 V - 1 Ph - 50 Hz			400 V - 3 Ph +N - 50 Hz		
Maximum length m	75					
Maximum height	30					
Pipe diameter (Liquid - Gas) inches	3/8 - 5/8					
Refrigerant R410A Charge kg	3.60					
Compressor	Scroll					
Refrigerant	R410A					
<b>OUTDOOR UNIT PRICE</b>						

(1) The nominal cooling and heating capacity is the combined capacity of the SET FREE system and is based on EN14511:

- Cooling: Indoor temperature 27°C DB ; 9°C WB , Outdoor temperature 35°C DB
- Heating: Indoor temperature 20°C DB; outdoor temperature 7°C DB, 6°C WB.
- Pipe length: 7.5m ; Height at 0m.

(2) The sound level measurement is performed in an anechoic camera at 1m from the frontal surface of the unit and at 1.5m from the ground level.

Guaranteed performance

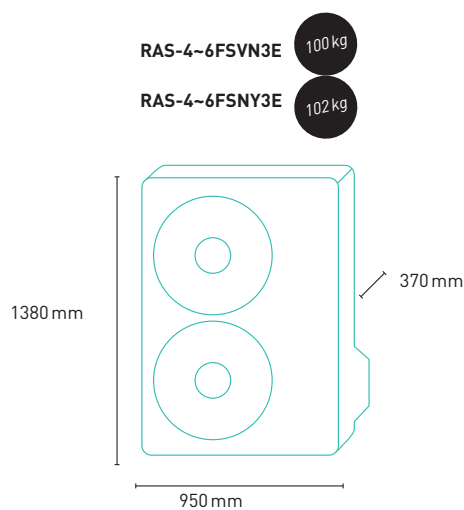
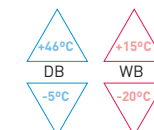

For more information about controls, see page 199.  
 Recommended prices - VAT not included, Waste Electrical and Electronic Equipment Directive (WEEE) fee not included.  
 To create the energy label visit our website [www.hitachiircon.es](http://www.hitachiircon.es) and use our Hitachi ErP Active Tool application.

## OUTDOOR UNIT SET FREE MINI

**FSNM**  
RAS-8~12FSNM



### CHARACTERISTICS

#### Unbeatable in kW per m2 installed, design and size

65% more power on the same surface compared to Top-Flow units, in addition to being 43% lighter.

#### Easy installation

With a width of only 390 mm, it can be installed in any small space, such as a balcony, as it also operates very quietly.

#### Scroll DC Inverter Compressor

More efficiency at partial loads and at low speed.

#### Flexibility

Compatible with all System Free indoor units, Hitachi management systems and building management software.

#### Compressor speed control

It controls between 20 and 100 Hz for coverage, also, with the needs of smaller spaces.

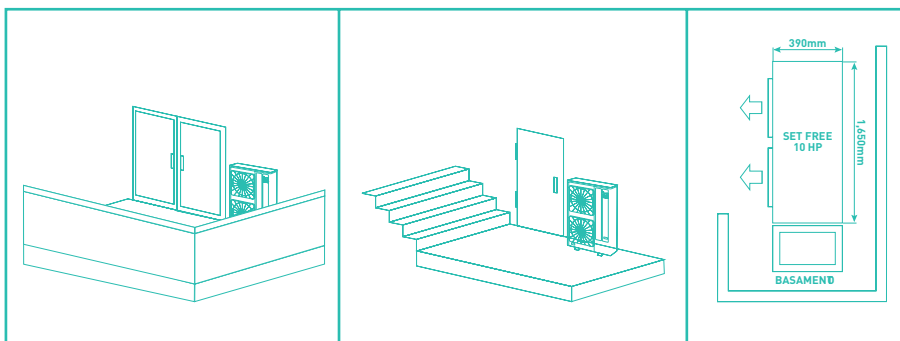

Pipe height and length

# FSNM



OUTDOOR UNITS	SET FREE MINI SIDE FLOW			
	RAS - 8FSNM	RAS - 10FSNM	RAS - 12FSNM	
Maximum number of units Connectible	10	10	10	
Nominal power <sup>(1)</sup>	Cooling kW	22.40	28.00	33.50
	Heating kW	25.00	31.50	37.50
Absorbed nominal power	Cooling kW	6.30	8.30	10.70
	Heating kW	5.90	7.80	9.90
EER - COP	3.56 - 4.24	3.37 - 4.04	3.13 - 3.79	
Sound pressure level (very low - low - medium - high) <sup>(2)</sup>	Cooling dB(A)	53	56	59
	Heating dB(A)	55	58	61
Airflow	m <sup>3</sup> /h	7260	9000	9780
Power supply	380-415 V - 3 Ph +N - 50 Ph			
Maximum length	100			
Maximum height	40/30			
Pipe diameter (Liquid - Gas)	inches	3/8 - 3/4	1/2 - 7/8	1/2 - 1 1/8
Refrigerant R410A Charge	kg	5.0	5.5	6.5
Compressor	Scroll			
Refrigerant	R410A	R410A	R410A	
<b>OUTDOOR UNIT PRICE</b>				

(1) The nominal cooling and heating capacity is the combined capacity of the SET FREE system and is based on EN14511:  
 - Cooling: Indoor temperature 27°C DB ; 9°C WB , Outdoor temperature 35°C DB  
 - Heating: Indoor temperature 20°C DB; outdoor temperature 7°C DB, 6°C WB.  
 - Pipe length: 7.5 m ; Height at 0 m.  
 (2) The sound level measurement is performed in an anechoic camera at 1 m from the frontal surface of the unit and at 1.5 m from the ground level.

Guaranteed performance

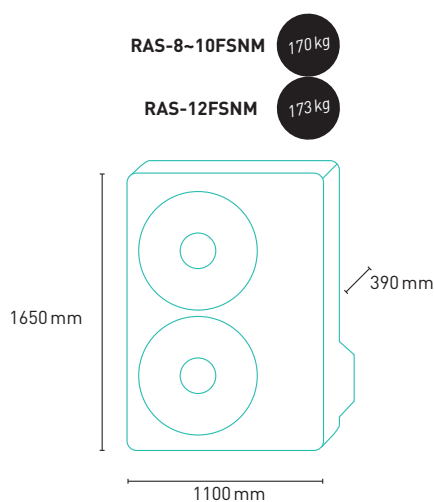
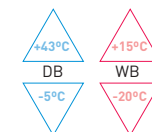

For more information about controls, see page 199.  
 Recommended prices - VAT not included, Waste Electrical and Electronic Equipment Directive (WEEE) fee not included.  
 To create the energy label visit our website [www.hitachiaircon.es](http://www.hitachiaircon.es) and use our Hitachi ErP AcTive Tool application.



# HIGH VRF PERFORMANCE

**Ideal for air conditioning large buildings**

**High performance range** that helps get building certification because of its high seasonal efficiency.

**ESEER2 up to 7.71**

**Minimum noise level.**

**Easy installation** without a crane and free configuration on the roof thanks to independent modules.

**Compatible** with all Hitachi control and management systems.

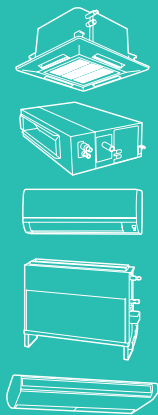

More information about compatible indoor units

▶ Page 96



More information about compatible controls and accessories

▶ Page 192



▶ Watch the video

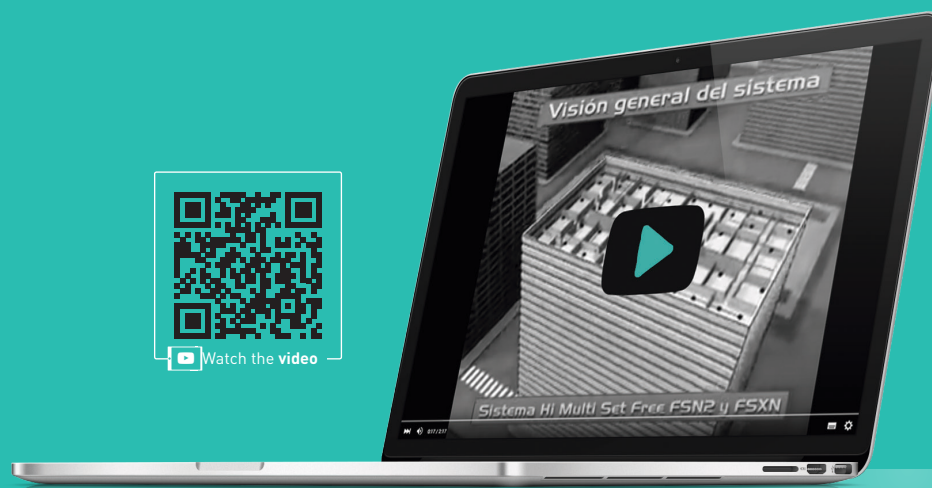



OPERATION OF  
**2 TO 3 COOLING AND  
HEATING PIPES**  
(SIMULTANEOUSLY)

AIR CONDITIONING FOR  
UP TO **64 DIFFERENT  
SPACES WITH  
INDEPENDENT  
CONTROL**



**MODULAR SYSTEM**  
COMBINATION OF  
MODULES ACCORDING  
TO REQUIRED POWER UP  
TO 54 HP

**TOTAL MAXIMUM LENGTH:  
300 TO 1000 M\***

*\*Depending on model*



**VRF SYSTEM**

MODULAR SET FREE HIGH SEASONAL PERFORMANCE

**FSXN1E**

RAS-8~54FSXN1E

**CHARACTERISTICS****High seasonal efficiency**

The Scroll DC Inverter compressor increases performance at partial loads by achieving an ESEER of 7.71 (depending on model).

**Flexibility**

Compatible with HITACHI System Free indoor units, individual or centralized control systems and building management software.

**Multiple capacity control**

It adjusts the refrigerant at all times according to the number of indoor units in operation.

**Easy installation of CH-Boxes**

Just 3 connections in the box. Adaptable to any building.

**Easily transportable**

The compact dimensions of the modules fit perfectly in an elevator.

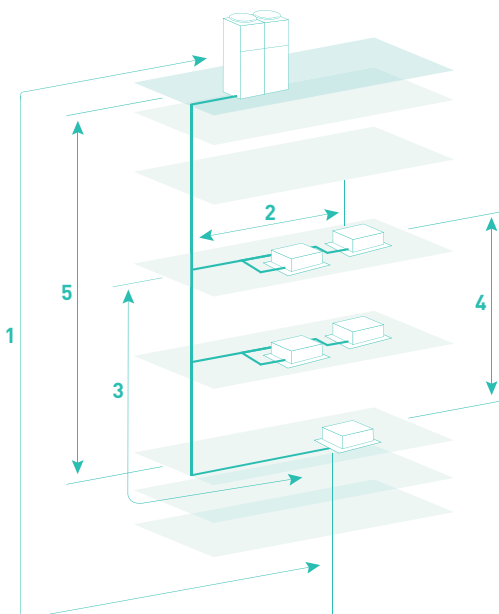
**Pipe height and lengths**

Maximum total length up to 1000 m:

1. Maximum pipe length: 165 m
2. Maximum length after branching: 30~40 m
3. Maximum length after the first multikit: 40~90 m
4. UI-UI height: maximum 30 m
5. Maximum height 90 m.

*Automatic consumption control*

For more information about controls, see page 199.



FSXN1E



OUTDOOR UNITS	RAS - 8FSXN1E	RAS - 10FSXN1E	RAS - 12FSXN1E	RAS - 14FSXN1E	RAS - 16FSXN1E	RAS - 16FSXN1E-P	RAS - 18FSXN1E
<b>COMBINED MODULES</b>							
						RAS-8FSXN1E RAS-10FSXN1E	RAS-8FSXN1E RAS-10FSXN1E
Maximum number of units Connectible	17	21	26	30	34	34	39
Nominal power <sup>(1)</sup>	Cooling	22.40	28.00	33.50	40.00	45.00	50.00
	Heating	22.40	28.00	33.50	40.00	45.00	56.00
Absorbed nominal power	Cooling	5.44	7.41	10.60	12.12	13.87	12.37
	Heating	5.23	6.56	6.73	10.93	13.72	13.72
EER - COP	4.12 - 4.28	3.78 - 4.27	3.16 - 3.98	3.30 - 3.66	3.24 - 3.28	4.10 - 4.15	4.04 - 4.08
Sound pressure level (night mode) <sup>(2)</sup>	58 [53]		60 [55]	62 [57]	64 [57]	61 [56]	61 [56]
ESEER <sup>(1)</sup>	6.07	5.86	5.54	4.86	4.77	5.95	5.95
ESEER <sup>(2)</sup>	7.71	7.45	7.08	6.17	6.06	7.56	7.56
Airflow	9300	10200	10500	11700	12600	19500	19500
Power supply	400 V - 3 Ph +N - 50 Hz				400 V - 3 Ph +N - 50 Hz		
Maximum length	165				165		
Maximum height	50/40				50/40		
Pipe diameter (Liquid - Gas)	3/8 - 3/4 - 5/8	3/8 - 7/8 - 3/4	1/2 - 1 - 7/8		1/2 - 1 1/8 - 7/8	5/8 - 1 1/8 - 7/8	
Refrigerant R410A Charge	5.40	6.40	7.30	8.50	9.50	11.80	11.80
Compressor	DC Scroll				2 DC Scroll		
Refrigerant	R410A	R410A	R410A	R410A	R410A	R410A	R410A

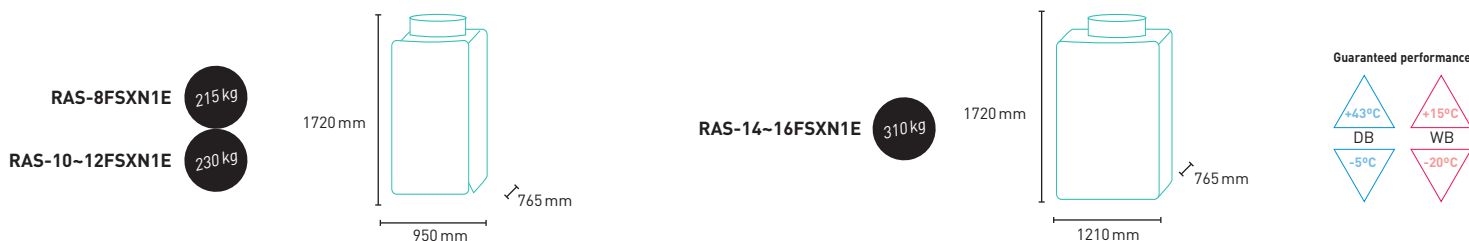

OUTDOOR UNITS	RAS - 20FSXN1E	RAS - 22FSXN1E	RAS - 24FSXN1E	RAS - 26FSXN1E	RAS - 28FSXN1E	RAS - 30FSXN1E
<b>COMBINED MODULES</b>						
	RAS-8FSXN1E RAS-12FSXN1E	RAS-8FSXN1E RAS-14FSXN1E	RAS-10FSXN1E RAS-14FSXN1E	RAS-12FSXN1E RAS-14FSXN1E	RAS-14FSXN1E RAS-14FSXN1E	RAS-14FSXN1E RAS-16FSXN1E
Maximum number of units Connectible	43	47	52	56	60	64
Nominal power <sup>(1)</sup>	Cooling	56.00	61.50	69.00	73.00	80.00
	Heating	63.00	69.00	77.50	82.50	90.00
Absorbed nominal power	Cooling	16.07	17.17	19.58	22.43	24.22
	Heating	16.17	18.17	20.57	22.33	24.88
EER - COP	3.48 - 3.90	3.58 - 3.80	3.52 - 3.77	3.25 - 3.69	3.30 - 3.62	3.27 - 3.34
Sound pressure level (night mode) <sup>(2)</sup>	63 [58]	64 [59]		65 [60]		66 [61]
ESEER <sup>(1)</sup>	5.66	5.27	5.18	5.16	4.86	4.81
ESEER <sup>(2)</sup>	7.22	6.70	6.59	6.58	6.17	6.12
Airflow	19800	21000	21900	22200	23400	24300
Power supply	400 V - 3 Ph +N - 50 Hz				400 V - 3 Ph +N - 50 Hz	
Maximum length	165				165	
Maximum height	50/40				50/40	
Pipe diameter (Liquid - Gas)	5/8 - 1 1/8 - 7/8	5/8 - 1 1/8 - 1	5/8 - 1 1/8 - 7/8	3/4 - 1 1/4 - 1	3/4 - 1 1/4 - 1 1/8	
Refrigerant R410A Charge	12.70	13.90	14.90	15.80	17.00	18.00
Compressor	2 DC Scroll	3 DC Scroll			4 DC Scroll	
Refrigerant	R410A	R410A	R410A	R410A	R410A	R410A

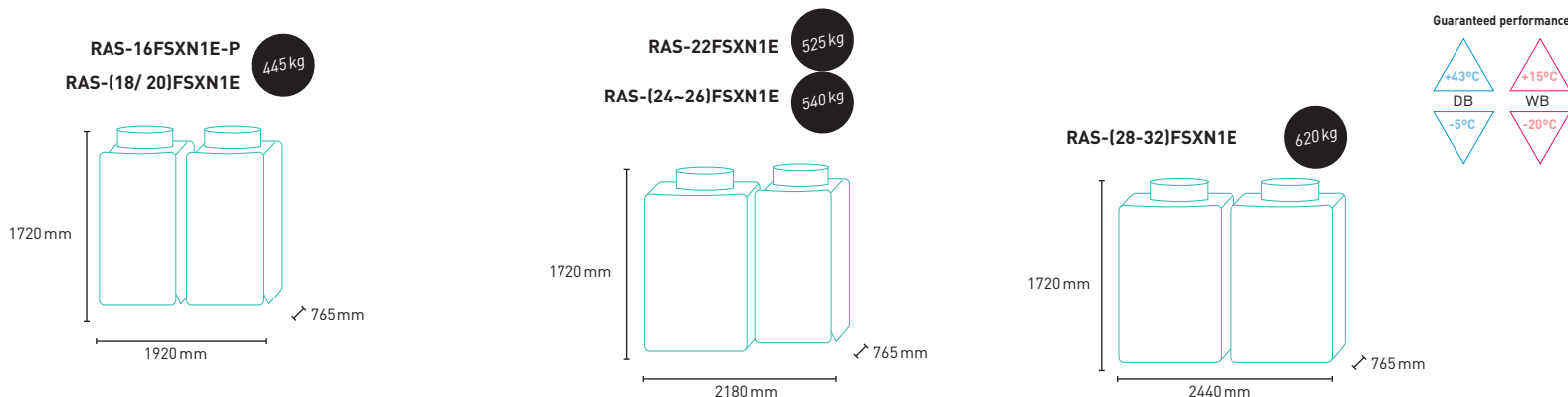

(1) The nominal cooling and heating capacity is the combined capacity of the SET FREE system and is based on EN14511:  
 - Cooling: Indoor temperature 27°C DB ; 9°C WB , Outdoor temperature 35°C DB  
 - Heating: Indoor temperature 20°C DB; outdoor temperature 7°C DB, 6°C WB.  
 - Pipe length: 7.5m ; Height at 0m.

(2) The sound level measurement is performed in an anechoic camera 1m from the frontal surface of the unit and 1.5m from the ground level with a tension of 230 V. The indicated data are based on cooling mode. In the case of heating, the sound pressure level increases from 1 to 2 dB(A)

(3) The maximum number of connectible indoor units varies depending on the model, capacity, environment and location of the connected indoor units. As a reference for the selection you should consult the Technical Catalog.

ESSER (1) Standard seasonal efficiency in cooling.  
 ESSER (2) Optimized system operation according to the demand for seasonal efficiency in cooling.



OUTDOOR UNITS	RAS - 32FSXN1E	RAS - 32FSXN1E-P	RAS - 34FSXN1E	RAS - 36FSXN1E	RAS - 38FSXN1E	RAS - 40FSXN1E	RAS - 42FSXN1E
COMBINED MODULES	RAS-16FSXN1E RAS-16FSXN1E	RAS-10FSXN1E RAS-12FSXN1E RAS-12FSXN1E	RAS-10FSXN1E RAS-12FSXN1E RAS-12FSXN1E	RAS-12FSXN1E RAS-12FSXN1E RAS-12FSXN1E	RAS-12FSXN1E RAS-12FSXN1E RAS-14FSXN1E	RAS-12FSXN1E RAS-12FSXN1E RAS-16FSXN1E	RAS-12FSXN1E RAS-14FSXN1E RAS-16FSXN1E
Maximum number of units Connectible	64	64	64	64	64	64	64
Nominal power <sup>(1)</sup>	Cooling	90.00	90.00	95.00	100.00	109.00	118.00
	Heating	100.00	100.00	106.00	112.00	118.00	132.00
Absorbed nominal power	Cooling	27.74	26.40	28.24	31.53	34.44	36.30
	Heating	32.06	25.32	27.30	29.43	31.25	38.07
EER - COP	3.24 - 3.12	3.40 - 3.95	3.36 - 3.88	3.17 - 3.81	3.16 - 3.78	3.19 - 3.49	3.25 - 3.47
Sound pressure level (night mode) <sup>(2)</sup>	65 (60)	65 (60)		66 (61)		67 (61)	67 (62)
ESEER <sup>(1)</sup>	4.77	5.62	5.58	5.56	5.17	5.19	5.01
ESEER <sup>(2)</sup>	6.06	7.17	7.11	7.10	6.59	6.62	6.38
Airflow	25200	31200		31500	32700	33600	34800
Power supply	400 V - 3 Ph +N - 50 Hz	400 V - 3 Ph +N - 50 Hz			400 V - 3 Ph +N - 50 Hz		
Maximum length	165			165			
Maximum height	50/40			50/40			
Pipe diameter (Liquid - Gas)	3/4 - 1 1/4 - 1 1/8			3/4 - 1 1/2 - 1 1/8		3/4 - 1 1/2 - 1 1/4	
Refrigerant R410A Charge	19.00	21.00	21.00	21.90	23.10	24.10	25.30
Compressor	4 DC Scroll	3 DC Scroll			4 DC Scroll		5 DC Scroll
Refrigerant	R410A	R410A	R410A	R410A	R410A	R410A	R410A

For specifications conditions, see notes in the table above.

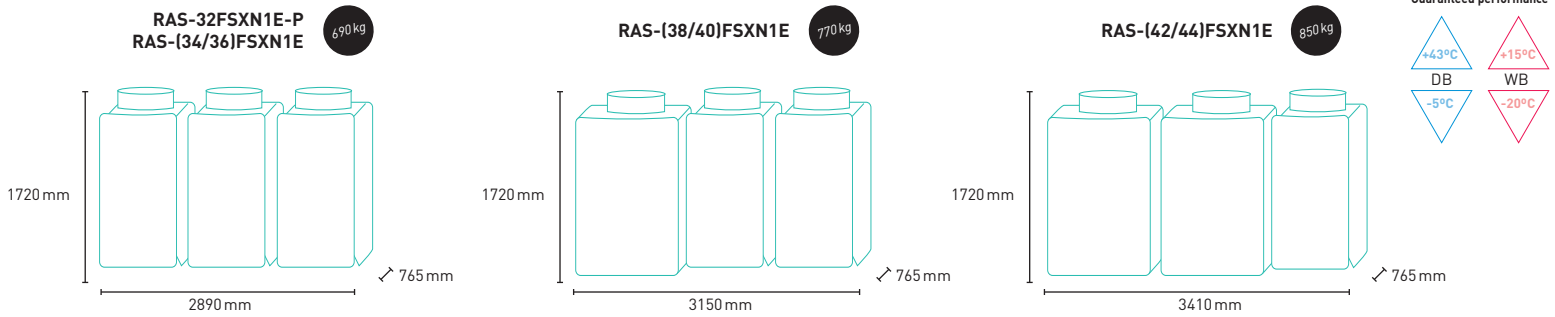

OUTDOOR UNITS	RAS - 44FSXN1E	RAS - 46FSXN1E	RAS - 48FSXN1E	RAS - 50FSXN1E	RAS - 52FSXN1E	RAS - 54FSXN1E
COMBINED MODULES	RAS-12FSXN1E RAS-16FSXN1E RAS-16FSXN1E	RAS-14FSXN1E RAS-16FSXN1E RAS-18FSXN1E	RAS-16FSXN1E RAS-16FSXN1E RAS-16FSXN1E	RAS-10FSXN1E RAS-12FSXN1E RAS-14FSXN1E RAS-14FSXN1E	RAS-12FSXN1E RAS-12FSXN1E RAS-14FSXN1E W v RAS-14FSXN1E	RAS - 10FSXN1E RAS - 12FSXN1E RAS - 14FSXN1E RAS - 14FSXN1E
Maximum number of units Connectible	64	64	64	64	64	64
Nominal power <sup>(1)</sup>	Cooling	125.00	132.00	136.00	140.00	145.00
	Heating	140.00	145.00	150.00	155.00	160.00
Absorbed nominal power	Cooling	39.19	40.96	42.12	41.04	44.32
	Heating	43.35	44.50	48.09	40.68	42.28
EER - COP	3.19 - 3.23	3.22 - 3.26	3.23 - 3.12	3.41 - 3.81	3.27 - 3.78	3.26 - 3.61
Sound pressure level (night mode) <sup>(2)</sup>	68 (62)	68 (63)	69 (63)	67 (62)	68 (63)	68 (63)
ESEER <sup>(1)</sup>	4.70	4.74	4.76	5.22	5.20	5.16
ESEER <sup>(2)</sup>	5.97	6.02	6.04	6.64	6.62	6.58
Airflow	35700	36900	37800	44100	44400	45300
Power supply	400 V - 3 Ph +N - 50 Hz			400 V - 3 Ph +N - 50 Hz		
Maximum length	165			165		
Maximum height	50/40			50 - 40		
Pipe diameter (Liquid - Gas)	3/4 - 1 1/2 - 1 1/4			3/4 - 1 1/2 - 1 1/4		
Refrigerant R410A Charge	26.30	27.50	28.50	30.70	31.60	32.60
Compressor	5 DC Scroll	6 DC Scroll				
Refrigerant	R410A	R410A	R410A	R410A	R410A	R410A

(1) The nominal cooling and heating capacity is the combined capacity of the SET FREE system and is based on EN14511:

- Cooling: Indoor temperature 27°C DB, 9°C WB, Outdoor temperature 35°C DB
- Heating: Indoor temperature 20°C DB; outdoor temperature 7°C DB, 6°C WB.
- Pipe length: 7.5 m; Height at 0 m.

(2) The sound level measurement is performed in an anechoic camera 1 m from the frontal surface of the unit and 1.5 m from the ground level with a tension of 230 V. The indicated data are based on cooling mode. In the case of heating, the sound pressure level increases from 1 to 2 dB(A)

(3) The maximum number of connectible indoor units varies depending on the model, capacity, environment and location of the connected indoor units. As a reference for the selection you should consult the Technical Catalog.

ESSER (1) Standard seasonal efficiency in cooling.  
ESSER (2) Optimized system operation according to the demand for seasonal efficiency in cooling.

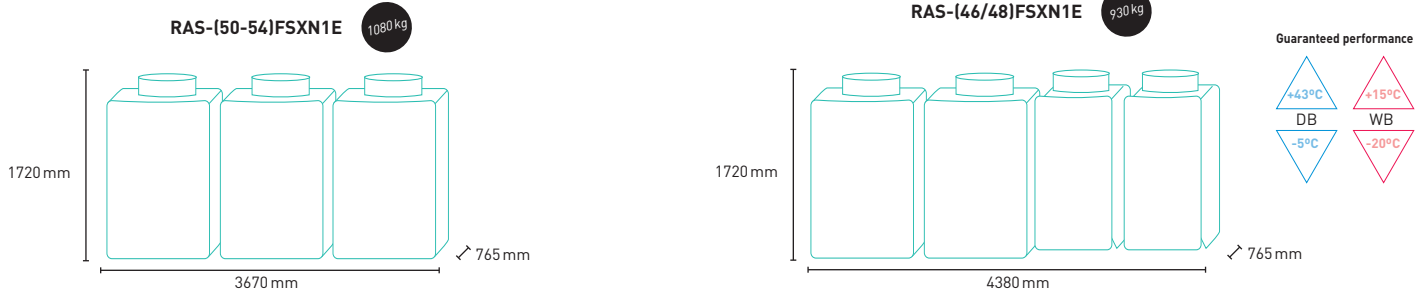

### SET FREE FSXN1E PRICE TABLE

OUTDOOR UNIT	COMBINATIONS	MULTIKITS 2 PIPES	PRICE	MULTIKITS 3 PIPES	PRICE
RAS - 8FSXN1E	Base model	-			
RAS - 10FSXN1E	Base model	-			
RAS - 12FSXN1E	Base model	-			
RAS - 14FSXN1E	Base model	-			
RAS - 16FSXN1E	Base model	-			
RAS - 16FSXN1E-P	RAS-8FSXN1E + RAS-10FSXN1E	-			
RAS - 18FSXN1E	RAS-8FSXN1E + RAS-10FSXN1E	MC-20AN1		MC-20XN1	
RAS - 20FSXN1E	RAS-8FSXN1E + RAS-12FSXN1E	MC-20AN1		MC-20XN1	
RAS - 22FSXN1E	RAS-8FSXN1E + RAS-14FSXN1E	MC-20AN1		MC-20XN1	
RAS - 24FSXN1E	RAS-10FSXN1E + RAS-14FSXN1E	MC-20AN1		MC-20XN1	
RAS - 26FSXN1E	RAS-12FSXN1E + RAS-14FSXN1E	MC-20AN1		MC-20XN1	
RAS - 28FSXN1E	RAS-14FSXN1E + RAS-14FSXN1E	MC-20AN1		MC-20XN1	
RAS - 30FSXN1E	RAS-14FSXN1E + RAS-16FSXN1E	MC-20AN1		MC-20XN1	
VRF Set Free Two or Three pipes FSXN1E	RAS - 32FSXN1E	RAS-16FSXN1E + RAS-16FSXN1E	MC-30AN1	MC-30XN1	
RAS - 32FSXN1E-P	RAS-10FSXN1E + RAS-12FSXN1E + RAS-12FSXN1E	MC-30AN1		MC-30XN1	
RAS - 34FSXN1E	RAS-10FSXN1E + RAS-12FSXN1E + RAS-12FSXN1E	MC-30AN1		MC-30XN1	
RAS - 36FSXN1E	RAS-12FSXN1E + RAS-12FSXN1E + RAS-12FSXN1E	MC-30AN1		MC-30XN1	
RAS - 38FSXN1E	RAS-12FSXN1E + RAS-12FSXN1E + RAS-14FSXN1E	MC-30AN1		MC-30XN1	
RAS - 40FSXN1E	RAS-12FSXN1E + RAS-12FSXN1E+ RAS-16FSXN1E	MC-30AN1		MC-30XN1	
RAS - 42FSXN1E	RAS-12FSXN1E + RAS-14FSXN1E + RAS-16FSXN1E	MC-30AN1		MC-30XN1	
RAS - 44FSXN1E	RAS-12FSXN1E + RAS-16FSXN1E + RAS-16FSXN1E	MC-30AN1		MC-30XN1	
RAS - 46FSXN1E	RAS-14FSXN1E + RAS-16FSXN1E + RAS-18FSXN1E	MC-30AN1		MC-30XN1	
RAS - 48FSXN1E	RAS-16FSXN1E + RAS-16FSXN1E + RAS-16FSXN1E	MC-30AN1		MC-30XN1	
RAS - 50FSXN1E	RAS-10FSXN1E + RAS-12FSXN1E + RAS-14FSXN1E + RAS-14FSXN1E	MC-40AN1		MC-40XN1	
RAS - 52FSXN1E	RAS-12FSXN1E + RAS-12FSXN1E + RAS-14FSXN1E + RAS-14FSXN1E	MC-40AN1		MC-40XN1	
RAS - 54FSXN1E	RAS-10FSXN1E + RAS-12FSXN1E + RAS-14FSXN1E + RAS-14FSXN1E	MC-40AN1		MC-40XN1	

### MULTIKIT 2 PIPES

#### MULTIKIT: 2 PIPE BRANCH PIPE

NAME	PRICE
E102SN4	
E-162SN4	
E-242SN3	
E-302SN3	

#### MULTIKIT: 2 PIPE COLLECTOR

NAME	PRICE
MH-84AN1	
MH-108AN	

### MULTIKIT 3 PIPES

#### MULTIKIT: 3 PIPE BRANCH PIPE

NAME	PRICE
E-52XN3	
E-102XN3	
E-162XN3	
E-242XN3	
E-322XN3	

#### MULTIKIT: 3 PIPE COLLECTOR

NAME	PRICE
MH-108XN	

#### CH RECOVERY BOXES

MODEL	CH-6.0N2	CH-10.0N2
Nominal capacity	HP<6	6<HP<10
Maximum number of indoor units connected	7	8
Electricity consumption	20 W	20 W
Price	Contact us	

For more information about controls, see page 199.  
 Recommended prices - VAT not included, Waste Electrical and Electronic Equipment Directive (WEEE) fee not included.  
 To create the energy label visit our website [www.hitachiaircon.es](http://www.hitachiaircon.es) and use our Hitachi ErP AcTive Tool application.





## VRF SYSTEM

### MODULAR SET FREE HIGH EFFICIENT

# FSXNH(E)

## RAS-5~36FSXNH



### CHARACTERISTICS

#### Easily transportable

The compact dimensions of the modules fit perfectly in an elevator.

#### Various combinations available

Possibility to choose between 5 individual models or in modular combinations, up to 36 HP.

#### High seasonal efficiency

The Scroll DC Inverter compressor increases performance of partial loads by achieving an ESEER of 8.79.

#### Intelligent demand control

It is possible to configure the demand according to the time slots, thus achieving significant savings on energy.

#### Flexibility

Compatible with HITACHI System Free indoor units, and individual or centralized control systems and building management systems.

#### Longer piping between outdoor and indoor units

The design and power of the outdoor unit allows indoor units to be installed farther away from them.

#### Improved blade design

The new blade design improves their behavior in heat mode, minimizing frost generation.

AUTOMATIC CONTROL OF ENERGY CONSUMPTION.  
THIS FUNCTION MAINTAINS THE ADJUSTED CURRENT VALUE.

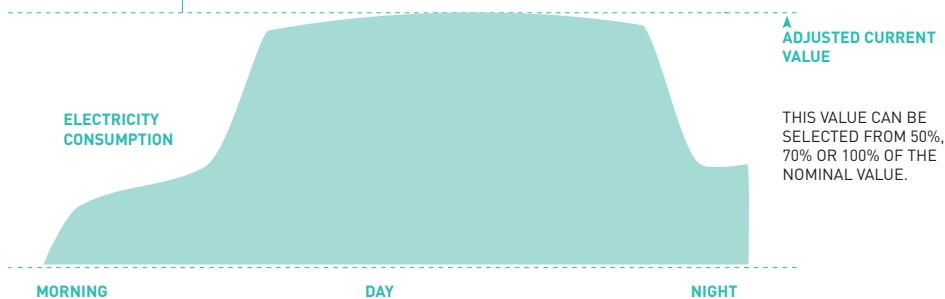

*Automatic consumption control*

FSXNH(E)



OUTDOOR UNITS	RAS-5FSXNH(E)	RAS-6FSXNH(E)	RAS-8FSXNH(E)	RAS-10FSXNH(E)	RAS-12FSXNH(E)
<b>COMBINED MODULES</b>					
Maximum number of units Connectible	10	13	17	21	26
Nominal power <sup>(1)</sup>	Cooling	14.00	16.00	22.40	28.00
	Heating	14.00	16.00	22.40	28.00
Absorbed nominal power	Cooling	3.12	3.51	4.81	6.67
	Heating	2.78	3.33	4.57	6.01
EER - COP <sup>(2)</sup>	4.49 - 5.04	4.56 - 4.81	4.66 - 4.90	4.20 - 4.66	3.93 - 4.40
ESEER <sup>(1)</sup>	6.61	6.71	6.86	6.39	5.79
ESEER <sup>(2)</sup>	8.40	8.53	8.72	8.12	7.35
Sound pressure level (night mode) <sup>(2)</sup>	dB(A)	55 [52]	56 [52]	58 [53]	59 [54]
Airflow	m <sup>3</sup> /h	8400	9300	9600	10500
Power supply	400 V - 30 Ph + N - 50 Hz				
Maximum length	165 m				
Maximum height (higher-lower)	50/40 m				
Pipe diameter (Liquid - Gas low - Gas high)	inches	3/8 - 5/8 - 1/2	3/8 - 3/4 - 5/8	3/8 - 3/4 - 5/8	3/8 - 7/8 - 3/4
Refrigerant Charge	kg	5.60		7.70	
Refrigerant fluid	R410A				
Compressor	1 Scroll DC Inverter Hermetic			1 Scroll DC Inverter Hermetic	

(1) The nominal cooling and heating capacity is the combined capacity of the SET FREE system and is based on EN14511:

- Cooling: Indoor temperature 27°C DB ; 9°C WB , Outdoor temperature 35°C DB

- Heating: Indoor temperature 20°C DB; outdoor temperature 7°C DB, 6°C WB.

- Pipe length: 7.5 m ; Height at 0 m.

(2) The sound level measurement is performed in an anechoic chamber at 1 m from the frontal surface of the unit and at 1.5 m from the ground level with a tension of 230 V. The indicated data are based on cooling mode. In the case of heating, the sound pressure level increases from 1 to 2 dB(A)

(3) The maximum number of connectible indoor units varies depending on the model, capacity, environment and location of the connected indoor units. As a reference for the selection, see the Technical Catalog.

ESSER (1) Standard seasonal efficiency in cooling.

ESSER (2) Optimized system operation according to the demand for seasonal efficiency in cooling.

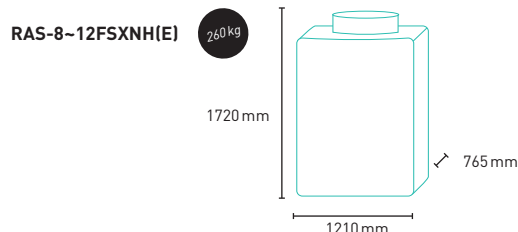
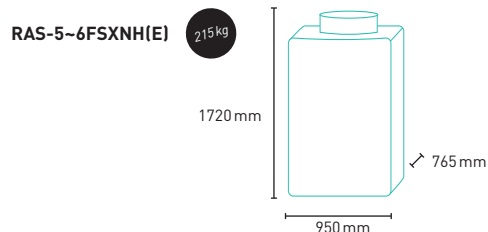

Guaranteed performance

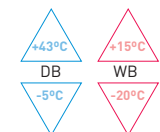

OUTDOOR UNITS	RAS-12FSXNH(E) - P	RAS-14FSXNH(E)	RAS-16FSXNH(E)	RAS-18FSXNH(E)	RAS-20FSXNH(E)
<b>COMBINED MODULES</b>					
	RAS-6FSXNH RAS-8FSXNH	RAS-6FSXNH RAS-8FSXNH	RAS-8FSXNH(E) RAS-8FSXNH(E)	RAS-8FSXNH(E) RAS-10FSXNH(E)	RAS-8FSXNH(E) RAS-12FSXNH(E)
Maximum number of units Connectible	26	30	34	39	43
Nominal power <sup>(1)</sup>	Cooling	33.50	40.00	45.00	50.00
	Heating	37.50	45.00	50.00	56.00
Absorbed nominal power	Cooling	7.13	8.74	9.67	11.15
	Heating	7.93	9.80	10.71	11.97
EER - COP <sup>(2)</sup>	4.70 - 4.73	4.58 - 4.59	4.65 - 4.67	4.48 - 4.68	4.19 - 4.31
ESEER <sup>(1)</sup>	6.92	6.74	6.85	6.60	6.17
ESEER <sup>(2)</sup>	8.79	8.57	8.70	8.38	7.84
Sound pressure level (night mode) <sup>(2)</sup>	dB(A)	61 [56]	61 [56]	61 [56]	62 [57]
Airflow	m <sup>3</sup> /h	18900	18900	19200	20100
Power supply	400 V - 30 Ph + N - 50 Hz				
Maximum length	165 m				
Maximum height (higher-lower)	50/40 m				
Pipe diameter (Liquid - Gas low - Gas high)	inches	1/2 - 1 - 7/8	1/2 - 1 - 7/8	1/2 - 1 1/8 - 7/8	5/8 - 1 1/8 - 7/8
Refrigerant Charge	kg	13.30		15.50	
Refrigerant fluid	R410A				
Compressor	2 Scroll DC Inverter Hermetic			2 Scroll DC Inverter Hermetic	

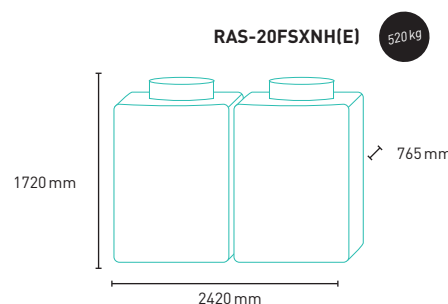
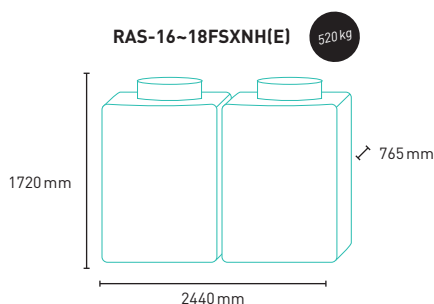
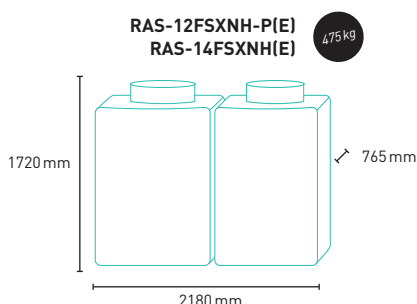

Guaranteed performance

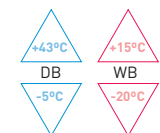



OUTDOOR UNITS	RAS-22FSXNH(E)	RAS-24FSXNH(E)	RAS-24FSXNH(E) - P	RAS-26FSXNH(E)	RAS-28FSXNH(E)
COMBINED MODULES	RAS-10FSXNH(E) RAS-12FSXNH(E)	RAS-12FSXNH(E) RAS-12FSXNH(E)	RAS-8FSXNH(E) RAS-8FSXNH(E) RAS-10FSXNH(E)	RAS-8FSXNH(E) RAS-8FSXNH(E) RAS-10FSXNH(E)	RAS-8FSXNH(E) RAS-8FSXNH(E) RAS-12FSXNH(E)
Maximum number of units Connectible	47	52	52	56	60
Nominal power <sup>(1)</sup>	Cooling	61.50	69.00	69.00	80.00
	Heating	69.00	77.50	77.50	90.00
Absorbed nominal power	Cooling	14.97	17.66	14.88	18.60
	Heating	15.86	18.96	16.71	20.50
EER - COP <sup>(2)</sup>	4.11 - 4.35	3.91 - 4.09	4.64 - 4.64	4.53 - 4.66	4.30 - 4.39
ESEER <sup>(1)</sup>	6.05	5.76	6.83	6.67	6.33
ESEER <sup>(2)</sup>	7.69	7.32	8.68	8.48	8.05
Sound pressure level (night mode) <sup>(2)</sup>	64 [59]	64 [59]	64 [59]	64 [59]	64 [59]
Airflow	22200	23400	29700	29700	30900
Power supply	400 V - 30 Ph + N - 50 Hz				
Maximum length	165 m				
Maximum height (higher-lower)	50/40 m				
Pipe diameter (Liquid - Gas low - Gas high)	5/8 - 1 1/8 - 7/8	5/8 - 1 1/8 - 7/8	3/4 - 1 1/4 - 1	3/4 - 1 1/4 - 1	3/4 - 1 1/4 - 1 1/8
Refrigerant Charge	16.00	16.60	23.00		23.70
Refrigerant fluid	R410A				
Compressor	2 Scroll DC Inverter Hermetic		3 Scroll DC Inverter Hermetic		3 Scroll DC Inverter Hermetic

Guaranteed performance

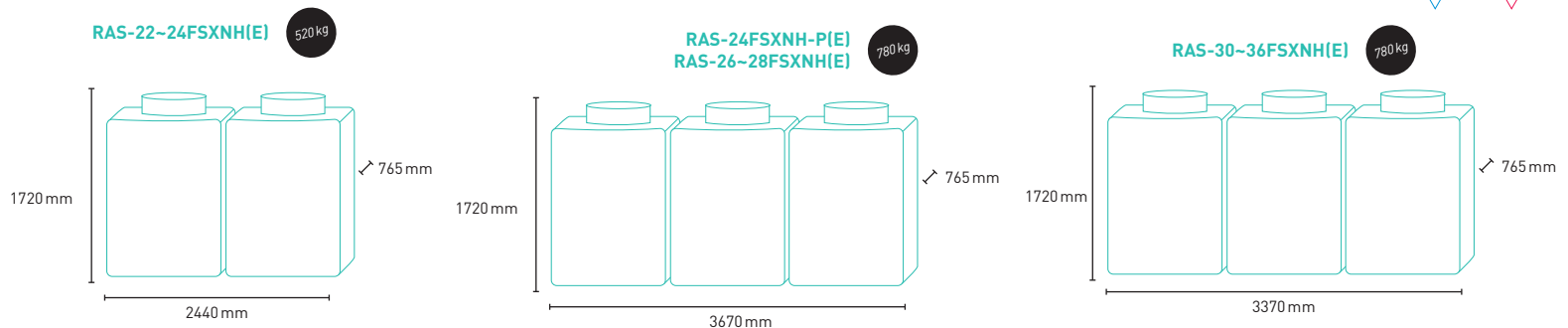
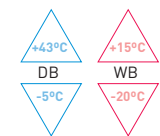

OUTDOOR UNITS	RAS-30FSXNH(E)	RAS-32FSXNH(E)	RAS-34FSXNH(E)	RAS-36FSXNH(E)
COMBINED MODULES	RAS-8FSXNH(E) RAS-10FSXNH(E) RAS-12FSXNH(E)	RAS-8FSXNH(E) RAS-12FSXNH(E) RAS-12FSXNH(E)	RAS-10FSXNH(E) RAS-12FSXNH(E) RAS-12FSXNH(E)	RAS-12FSXNH(E) RAS-12FSXNH(E) RAS-12FSXNH(E)
Maximum number of units Connectible	64	64	64	64
Nominal power <sup>(1)</sup>	Cooling	85.00	90.00	100.00
	Heating	95.00	100.00	112.00
Absorbed nominal power	Cooling	20.07	22.00	25.44
	Heating	21.49	23.60	27.24
EER - COP <sup>(2)</sup>	4.24 - 4.42	4.09 - 4.24	4.05 - 4.27	3.93 - 4.11
ESEER <sup>(1)</sup>	6.24	6.02	5.96	5.79
ESEER <sup>(2)</sup>	7.93	7.65	7.58	7.35
Sound pressure level (night mode) <sup>(2)</sup>	65 [60]	65 [60]	66 [61]	66 [61]
Airflow	31800	33000	33900	35100
Power supply	400 V - 30 Ph + N - 50 Hz			
Maximum length	165 m			
Maximum height (higher-lower)	50/40 m			
Pipe diameter (Liquid - Gas low - Gas high)	3/4 - 1 1/4 - 1 1/8	3/4 - 1 1/4 - 1 1/8	3/4 - 1 1/4 - 1 1/8	3/4 - 1 1/4 - 1 1/8
Refrigerant Charge	23.70	24.30		24.90
Refrigerant fluid	R410A			
Compressor	3 Scroll DC Inverter Hermetic			

(1) The nominal cooling and heating capacity is the combined capacity of the SET FREE system and is based on EN14511:

- Cooling: Indoor temperature 27°C DB ; 9°C WB , Outdoor temperature 35°C DB  
- Heating: Indoor temperature 20°C DB; outdoor temperature 7°C DB, 6°C WB.  
- Pipe length: 7.5 m; Height at 0 m.

(2) The sound level measurement is performed in an anechoic camera 1 m from the frontal surface of the unit and 1.5 m from the ground level with a tension of 230 V. The indicated data are based on cooling mode. In the case of heating, the sound pressure level increases from 1 to 2 dB(A)

(3) The maximum number of connectible indoor units varies depending on the model, capacity, environment and location of the connected indoor units. As a reference for the selection you should consult the Technical Catalog.

ESSER (1) Standard seasonal efficiency in cooling.

ESSER (2) Optimized system operation according to the demand for seasonal efficiency in cooling.



### SET FREE FSXNH(E) PRICE TABLE

OUTDOOR UNIT	COMBINATIONS	MULTIKITS 2 PIPES	PRICE	MULTIKITS 3 PIPES	PRICE
RAS-5FSXNH(E)	Base model	-			
RAS-6FSXNH(E)	Base model	-			
RAS-8FSXNH(E)	Base model	-			
RAS-10FSXNH(E)	Base model	-			
RAS-12FSXNH(E)	RAS-6FSXNH + RAS-8FSXNH(E)	-			
RAS-12FSXNH(E) - P	RAS-6FSXNH + RAS-8FSXNH(E)	-			
RAS-14FSXNH(E)	RAS-8FSXNH(E) + RAS-8FSXNH(E)	MC-20AN1		MC-20XN1	
RAS-16FSXNH(E)	RAS-8FSXNH(E) + RAS-10FSXNH(E)	MC-20AN1		MC-20XN1	
RAS-18FSXNH(E)	RAS-8FSXNH(E) + RAS-12FSXNH(E)	MC-20AN1		MC-20XN1	
VRF Set Free Two or Three pipes FSXNH(E)	RAS-10FSXNH(E) + RAS-12FSXNH(E)	MC-20AN1		MC-20XN1	
	RAS-12FSXNH(E) + RAS-12FSXNH(E)	MC-20AN1		MC-20XN1	
	RAS-8FSXNH(E) + RAS-8FSXNH(E) + RAS-10FSXNH(E)	MC-20AN1		MC-20XN1	
	RAS-8FSXNH(E) + RAS-8FSXNH(E) + RAS-10FSXNH(E)	MC-20AN1		MC-20XN1	
	RAS-8FSXNH(E) + RAS-8FSXNH(E) + RAS-12FSXNH(E)	MC-30AN1		MC-30XN1	
	RAS-8FSXNH(E) + RAS-10FSXNH(E) + RAS-12FSXNH(E)	MC-30AN1		MC-30XN1	
	RAS-8FSXNH(E) + RAS-12FSXNH(E) + RAS-12FSXNH(E)	MC-30AN1		MC-30XN1	
	RAS-10FSXNH(E) + RAS-12FSXNH(E) + RAS-12FSXNH(E)	MC-30AN1		MC-30XN1	
	RAS-12FSXNH(E) + RAS-12FSXNH(E) + RAS-12FSXNH(E)	MC-30AN1		MC-30XN1	
	RAS-12FSXNH(E) + RAS-12FSXNH(E) + RAS-12FSXNH(E)	MC-30AN1		MC-30XN1	

### MULTIKIT 2 PIPES

MULTIKIT: 2 PIPE BRANCH PIPE	
NAME	PRICE
E102SN4	
E-162SN4	
E-242SN3	
E-302SN3	

MULTIKIT: 2 PIPE COLLECTOR	
NAME	PRICE
MH-84AN1	
MH-108AN	

### MULTIKIT 3 PIPES

MULTIKIT: 3 PIPE BRANCH PIPE	
NAME	PRICE
E-52XN3	
E-102XN3	
E-162XN3	
E-242XN3	
E-322XN3	

  

MULTIKIT: 3 PIPE COLLECTOR	
NAME	PRICE
MH-108XN	

### CH RECOVERY BOXES

MODEL	CH-6.0N2	CH-10.0N2
Nominal capacity	HP<6	6<HP<10
Maximum number of indoor units connected	7	8
Electricity consumption	20 W	20 W
Price	Contact us	

For more information about controls, see page 199.  
 Recommended prices - VAT not included, Waste Electrical and Electronic Equipment Directive (WEEE) fee not included.  
 To create the energy label visit our website [www.hitachiircon.es](http://www.hitachiircon.es) and use our Hitachi ErP AcTive Tool application.

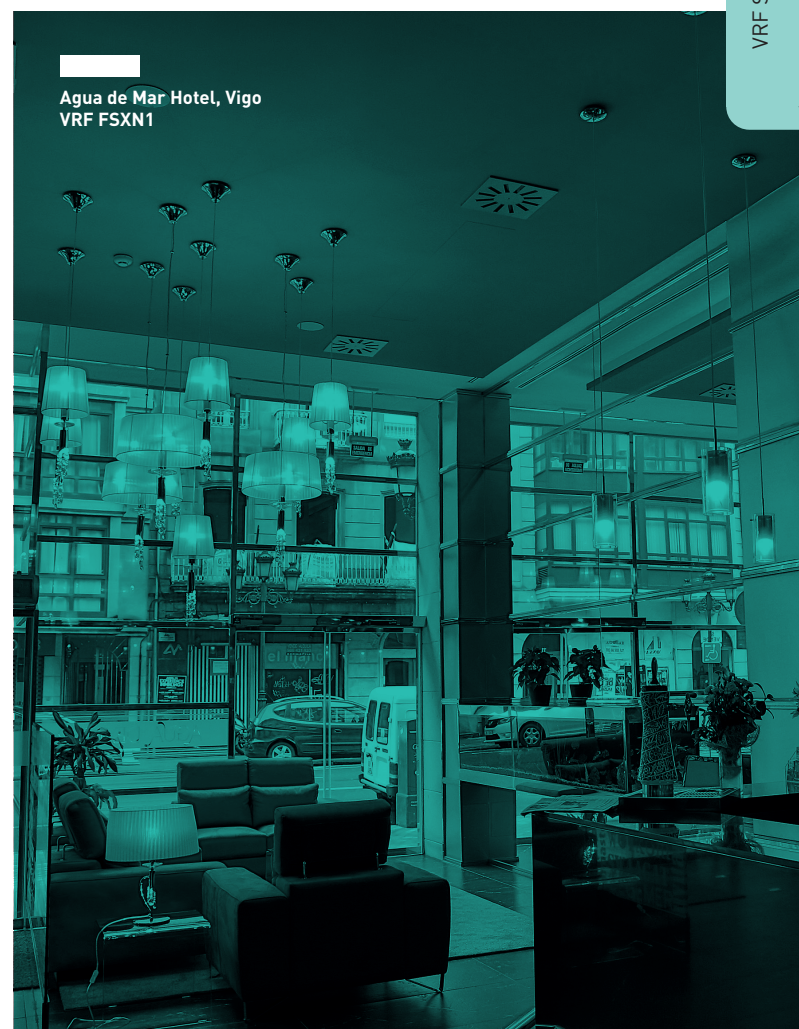



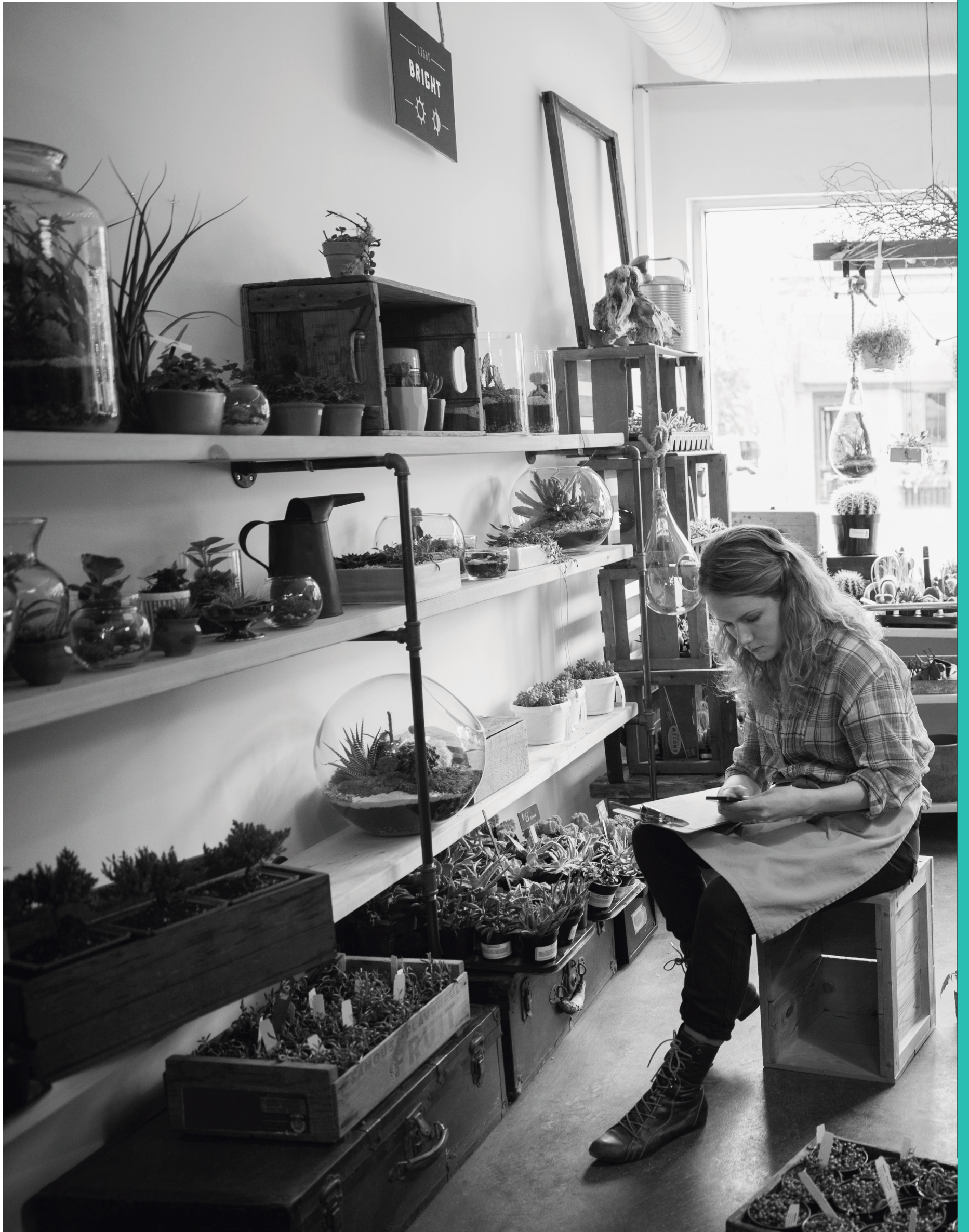



# AIR RE NEW AL





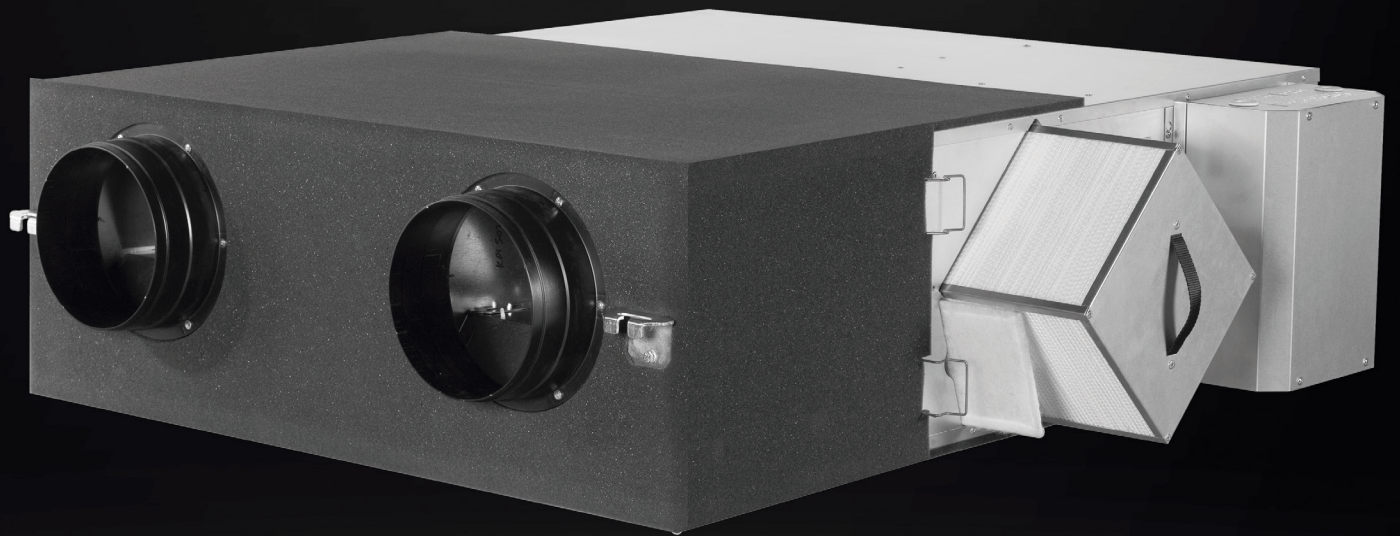

# AIR RENEWAL

**AIR RENEWAL** **182**

VENTILATION

KPI	183
ACTIVE KPI	185
ECONOFRESH	187

**KPI**

HIGH EFFICIENCY AIR RENEWAL

**VENTILATION**

KPI-252~2002(E)4E

**CHARACTERISTICS****Versatile ventilation systems**

Three different modes of operation: heat recovery, free and/or automatic ventilation.

**Noise reduction**

It has sound attenuator that reduces noise by up to 5 dB(A) (depending on model).

**Guaranteed air purification**

The G3 filters are available in the external air intake and inward drive, as well as the F7 Filter.

**High control capacity**

Control of the static pressure of the fans through the base plate.

**Energy conservation**

To avoid wasting additional energy, air is used through the heat exchanger, which prepares the outside air with the indoor temperature.

**Compliance with regulations**

Adaptation to the 2018 ErP regulation and to the new Lot. 11 and 1253/2014 Lot6 regulations.

**CO2 sensor for automatic ventilation**

Two options available:

- Automatic speed mode. It regulates the fan speed to constantly eliminate CO2.
- High concentration of CO2. The fan quickly displaces CO2 when high levels are detected.

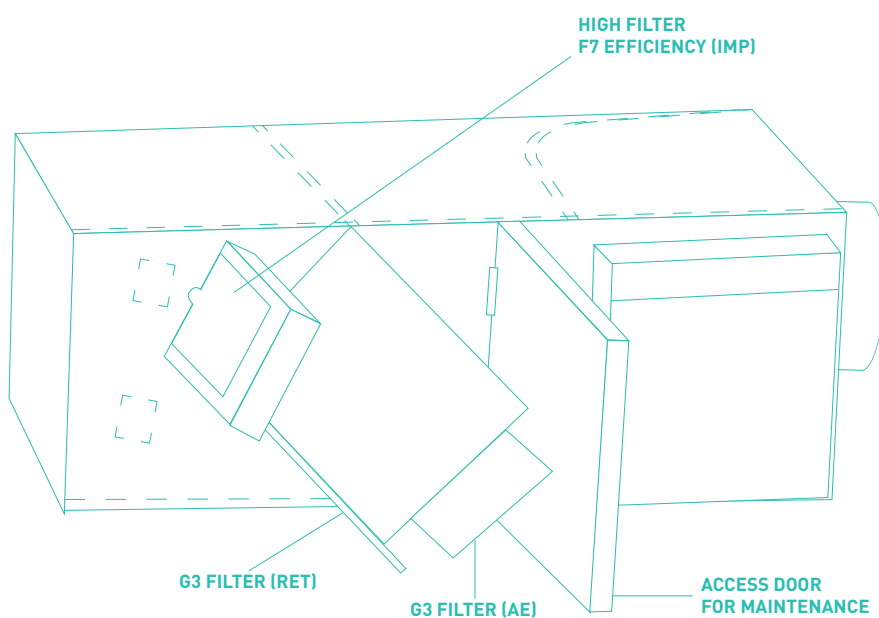

G3: Gravimetric efficiency filter up to 90%  
F7: Fine dust efficiency filter up to 90%



### KPI. HIGH EFFICIENCY AIR RENEWAL

MODEL			KPI-252E4E	KPI-502E4E	KPI-802E4E	KPI-1002E4E	KPI-1502E4E	KPI-2002E4E
Indoor unit power supply			1~230 V 50 Hz					
Airflow. Speed (low - medium - high)	E3E	m3/h	180 - 208 - 250	360 - 420 - 500	540 - 650 - 800	620 - 800 - 1000	950 - 1250 - 1500	1200 - 1450 - 2000
Static pressure. Speed (low - medium - high) <sup>(1)</sup>	E3E	Pa	30 - 35 - 55	37 - 50 - 80	40 - 60 - 90	40 - 65 - 95	45 - 70 - 100	40 - 65 - 120
Maximum outdoor static pressure at nominal airflow		Pa	240	210	120	190	200	170
Type of exchanger (material)			Cellulose					
Heat exchanger efficiency <sup>(2)</sup>	E3E	%	74 - 77 - 79	74 - 77 - 78	75 - 76 - 78	78 - 81 - 83	73 - 76 - 80	76 - 78 - 80
Enthalpy exchange efficiency for heating (high)	E3E	%	66	65	65	68	68	66.50
Enthalpy exchange efficiency for cooling (high)	E3E	%	60	61	62	62	62.50	61.50
Sound pressure level	E3E	dB(A)	43	51	54	55	56	57
Borehole connection diameter		mm	160	200	250	300	355	355
Absorbed nominal input power (High)		W	48	117	243	261	462	666
Filter class <sup>(3)</sup>			G3					
Maximum outdoor operating temperatures <sup>(3)</sup>			46°C (DB)					
Control (optional - not included in the price)			PC-ARFPE					
<b>PRICE</b>								

(1) Default fan pressure setting  
 (2) Measured in accordance with EN 308  
 (3) High efficiency filter classified as F7 (EN779) optional

#### HIGH EFFICIENCY FILTER (F7)\*

References	HEF - 252	HEF - 502	HEF - 802	HEF - 1002	HEF - 1502	HEF - 2002
Valid for	KPI-252E4E	KPI-502E4E	KPI-802E4E	KPI-1002E4E	KPI-1502E4E	KPI-2002E4E
<b>PRICE</b>						

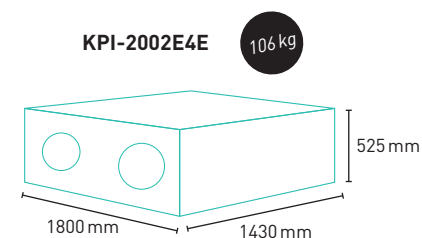
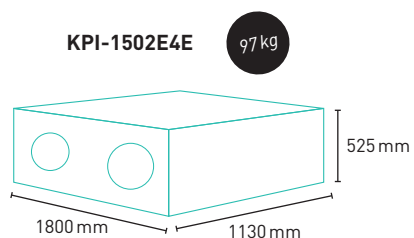
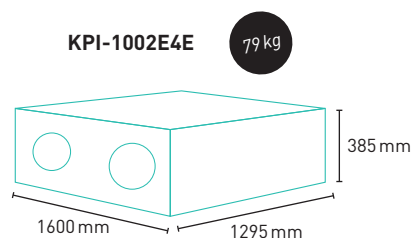
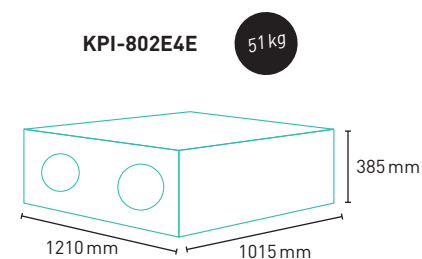
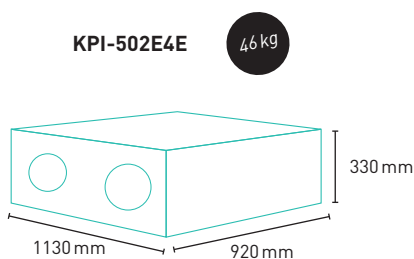
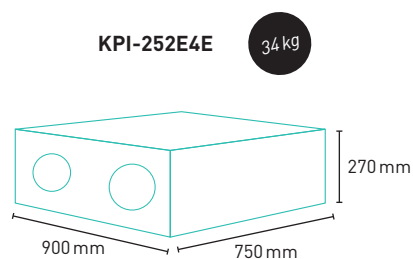

For more information about controls, see page 199.  
 Recommended prices - VAT not included, Waste Electrical and Electronic Equipment Directive (WEEE) fee not included.  
 To create the energy label visit our website [www.hitachiaircon.es](http://www.hitachiaircon.es) and use our Hitachi ErP AcTive Tool application.

**ACTIVE KPI**

HIGH EFFICIENCY RECOVERY

**VENTILATION**

KPI-502~1002X4E

**CHARACTERISTICS****New Active KPI-X4E**

With direct expansion battery, which air-conditions the outside air according to indoor needs.

**Compliance with regulations**

Adaptation to the 2018 ErP regulation and to the new Lot. 11 and 1253/2014 Lot6 regulations.

**Guaranteed air purification**

G3 filters are available in the outdoor air intake and inward drive, as well as the F7 Filter.

**Versatile ventilation systems**

Three different modes of operation: heat recovery, free and/or automatic ventilation.

**Automatic control of starting of external electrical resistance**

Electric resistance comes into operation when the temperature drops below -5°C. Recommended operation when high air discharge temperatures are required.

**Flexibility**

The Active KPI is compatible with:  
 -UTOPIA, 2 and 2.5 HP  
 - VRF Set Free: FS(V)N(Y)3E, FSXN, FSNM, FSN2.

**Air adaptation**

Air is adapted to the conditions that the premises need thanks to additional treatment before being introduced into the indoor setting.

**Available options**

CO2 sensor for automatic ventilation.  
 Control of the static pressure of the fans through the base plate.

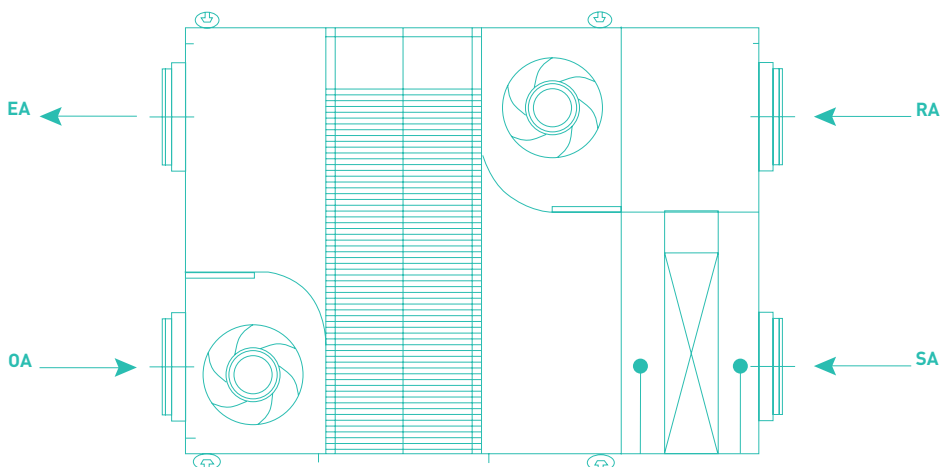

G3: Gravimetric efficiency filter up to 90%  
 F7: Fine dust efficiency filter up to 90%

## ACTIVE KPI. HIGH EFFICIENCY AIR RENEWAL

MODEL		KPI-502X4E	KPI-802X4E	KPI-1002X4E
Indoor unit power supply		1~230 V 50 Hz		
Nominal Cooling power <sup>(1)</sup>	kW	5.32 (1.81)	7.96 (2.94)	10.83 (3.73)
Nominal Heating power <sup>(1)</sup>		6.92 (2.12)	9.79 (3.49)	12.93 (4.43)
Airflow speed (low - medium - high)	m <sup>3</sup> /h	380 - 430 - 500	590 - 700 - 800	740 - 820 - 1000
Static pressure, speed (low - medium - high) <sup>(2)</sup>	Pa	60 - 82 - 90	57 - 80 - 110	80 - 105 - 170
Maximum outdoor static pressure at nominal airflow	Pa	200	110	170
Type of exchanger (material)		Cellulose		
Heat exchanger efficiency (high - medium - low) <sup>(3)</sup>	%	74 - 77 - 78	75 - 76 - 78	78 - 81 - 83
Enthalpy exchange efficiency for heating (high)	%	65	65	68
Enthalpy exchange efficiency for cooling (high)	%	61	62	62
Sound pressure level <sup>(4)</sup> (low - medium - high)	dB(A)	29 - 30 - 32	32 - 33 - 34	31 - 33 - 36
Sound power	dB(A)	50	53	54
Borehole connection diameter	mm	200	250	300
Nominal input power (high)	W	130	255	357
Filter class <sup>(5)</sup>		G3		
Maximum outdoor operating temperatures <sup>(4)</sup>		-20°C (DB) ~ 46°C (DB)		
Control (not included in the price)		PC-ARFPE		
<b>PRICE</b>				

(1) The nominal cooling and heating capacity is the combined capacity of the indoor and outdoor units and is based on EN14511

- Cooling: 27°C DB , 19°C WB. Outdoor temperature 35°C DB , 24°C WB

- Heating: 20°C DB , 24°C WB. Outdoor temperature 7°C DB , 6°C WB. Pipe length 7.5 m

(2) Default fan pressure setting

(3) Measured in accordance with EN 308

(4) Sound pressure level measured in an anechoic camera at a distance of 1.5 m below the unit, without ceiling under the unit and using the isolated sound of the duct, this reflects that the sound must be considered when the unit is installed at the site, because the pressure level measured in the installation may be higher than the specified pressure level.

(5) High efficiency filter classified as F7 (EN779) optional

### HIGH EFFICIENCY FILTER (F7)\*

References	HEF - 502	HEF - 802	HEF - 1002
Valid for	KPI-502X4E	KPI-802X4E	KPI-1002X4E
<b>PRICE</b>			

### ACOUSTIC ATTENUATOR

References	STL - 30 - 200 - L600	STL - 30 - 250 - L600
Valid for	KPI - 502	KPI - 802/1002
<b>PRICE</b>		

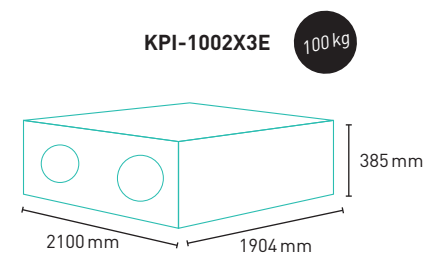
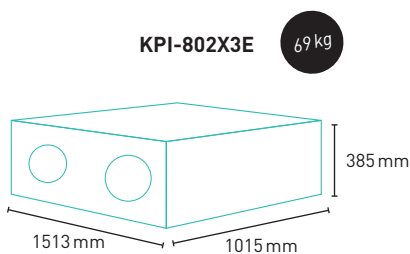
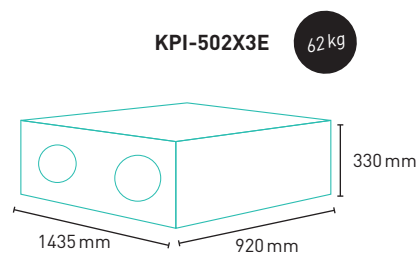

For more information about controls, see page 199.

Recommended prices - VAT not included, Waste Electrical and Electronic Equipment Directive (WEEE) fee not included.

To create the energy label visit our website [www.hitachiircon.es](http://www.hitachiircon.es) and use our Hitachi ErP Active Tool application.



## ECONOFRESH

### HIGH EFFICIENCY AIR RECOVERY

# VENTILATION

EF - 456NE

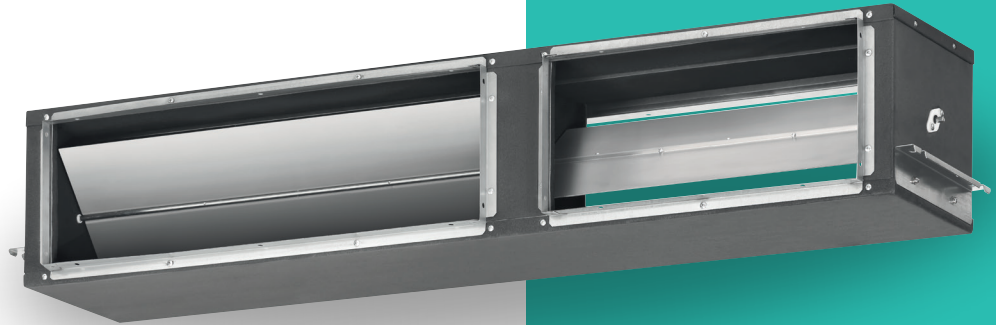

## CHARACTERISTICS

A suitable solution for premises with high thermal loads that need cooling throughout the year, even in winter.

### Important energy savings

Intelligent management of air recovery.

### CO2 Management

Reduction of CO2 levels, elimination of odors, smoke and pollution.

### Econofresh Kit

Energy conservation in the intermediate seasons.

### Free Cooling

Energy conservation in the air system through "Natural Cooling", which uses outside air to cool and renew the indoor air when the outdoor temperature is lower than the indoor temperature.

### Product novelty

- Compatible with 4~6 HP duct units (RPI 4~6FSN4E.)
- The minimum outdoor aperture can be selected from the remote control.
- Optional F7 filter.
- Control of the indoor unit via the remote control.

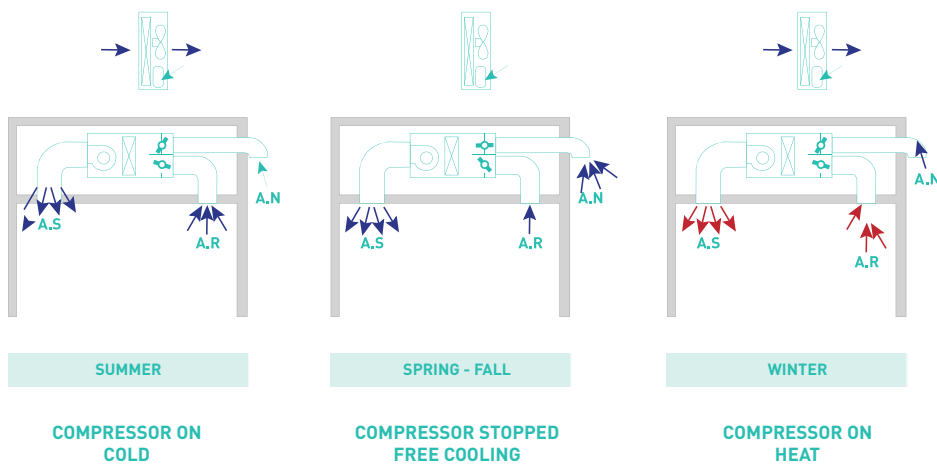

*Free Cooling Operation*

## ECONOFRESH KIT

<b>MODEL</b>	<b>EF - 456NE</b>
<b>COMBINABLE INDOOR UNIT MODEL</b>	<b>RPI- 4-6FSN4E*</b>
No. of actuator motors	1
Standard accessories	Outdoor air entrance temperature probe
Optional accessories	HE - EF456
<b>PRICE</b>	

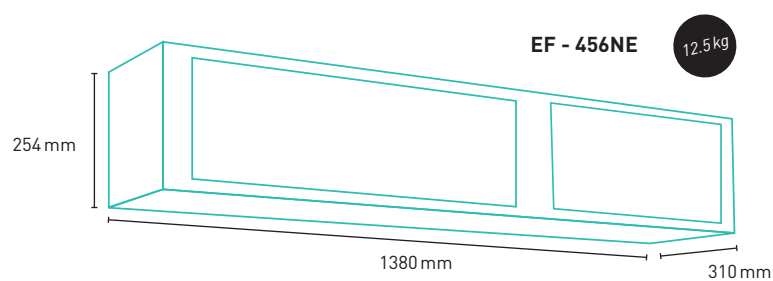

### RPI CONNECTION SCHEME WITH THE ECONOFRESH KIT

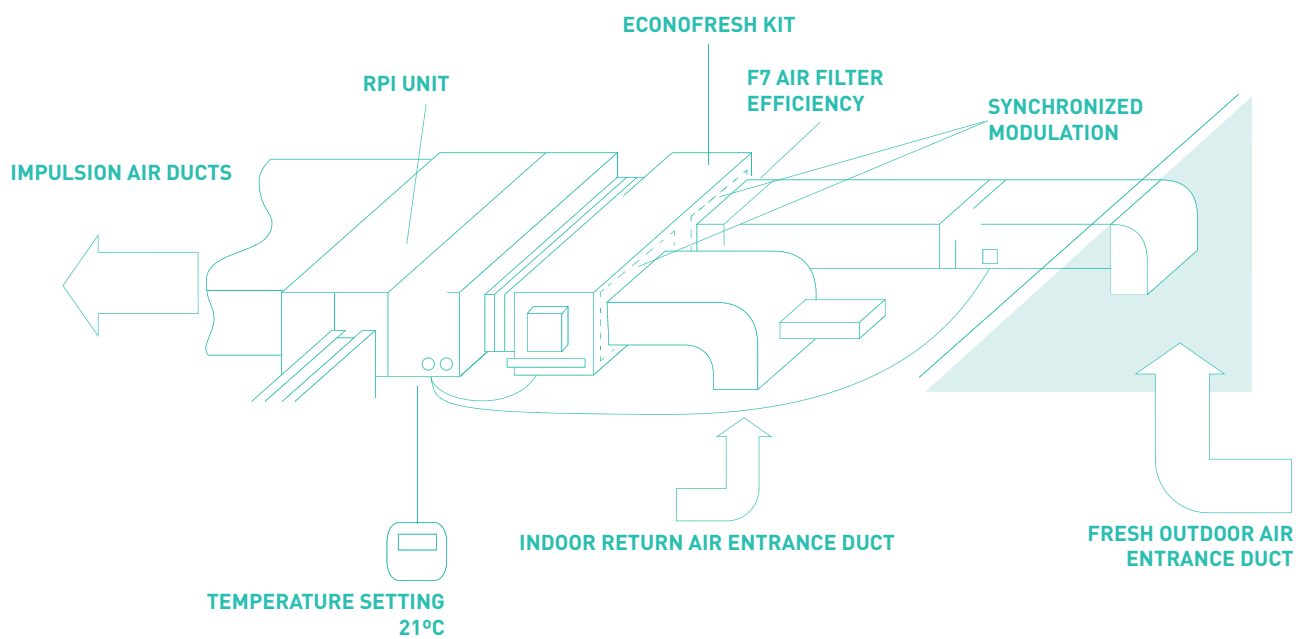

For more information about controls, see page 199.  
 Recommended prices - VAT not included, Waste Electrical and Electronic Equipment Directive (WEEE) fee not included.  
 To create the energy label visit our website [www.hitachiircon.es](http://www.hitachiircon.es) and use our Hitachi ErP AcTive Tool application.







# CON TROLS

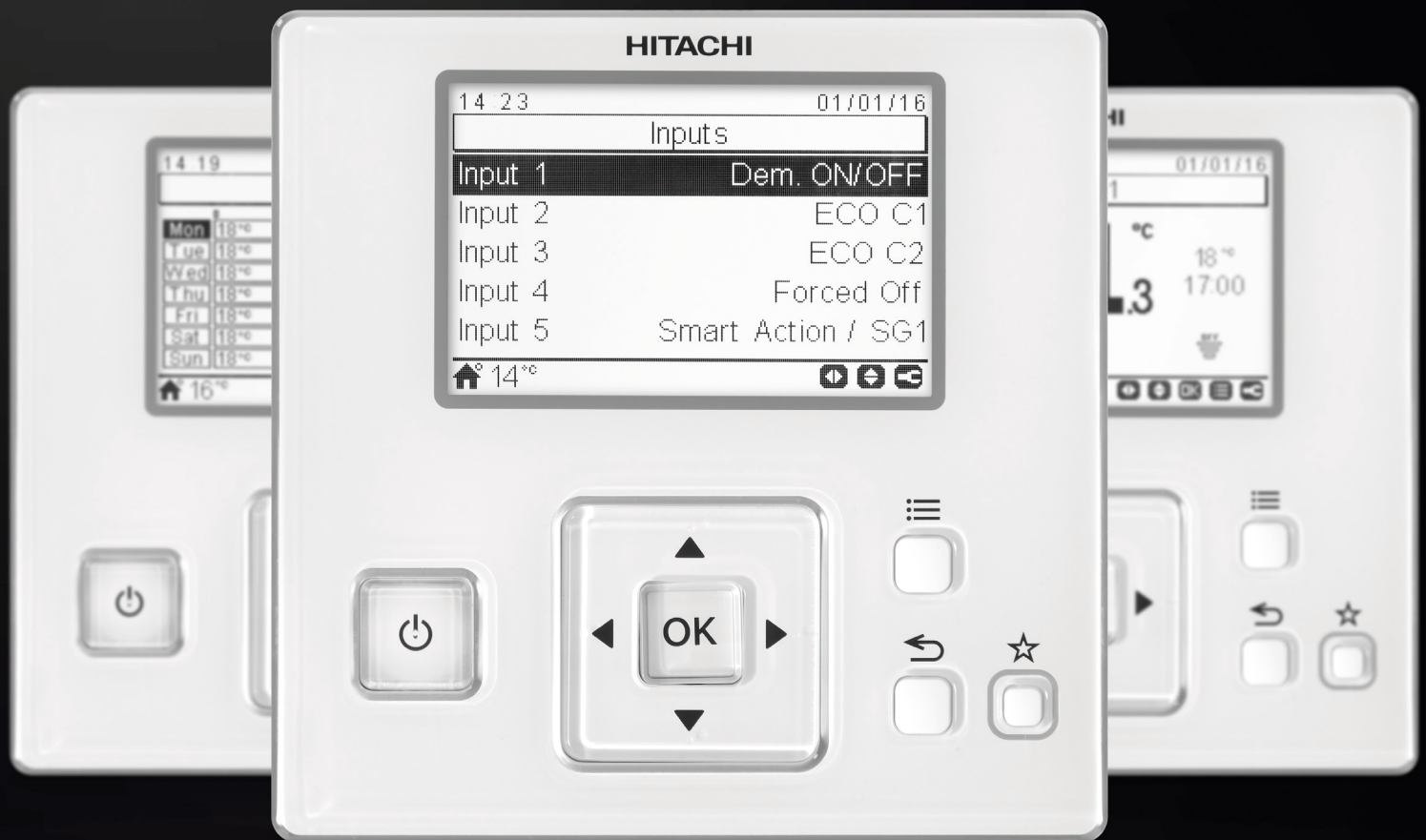

# CONTROLS

## AND ACCESSORIES

<b>CONTROLS AND ACCESSORIES</b>	<b>192</b>
<hr/>	
CONTROLS	
RESIDENTIAL	193
HEATING	195
COMMERCIAL AND VRF	199
ACCESSORIES	
CS-NET WEB	205
COMMUNICATION	206



## CONTROLS AND ACCESSORIES

## RESIDENTIAL

## INFRARED ECOCONTROL CONTROL

RAR-5E5 / RAR-6N5

**CHARACTERISTICS:**

- LCD Screen.
- Weekly program.
- Away from home mode.
- Eco Mode.
- Sleep (7hr).
- Multifunction: temperature, ventilation, self-diagnosis and more.

**RAR-5E5** COMPATIBLE WITH:  
Monoduct RAD25~50RPA.  
Ducts RAD-50~70RPA.

PRICE:

**RAR-6N5** COMPATIBLE WITH:  
RAD-18~50QPB.

PRICE:

## WIRED REMOTE CONTROL

SPX-RCDA

**CHARACTERISTICS:**

- Wall mounting.
- 12 hour program.
- Away from home.
- Multifunction: modes, temperatures, ventilation, night mode.

**SPX-RCDA** COMPATIBLE WITH:  
RAD-25~50RPA.  
RAD-50~70PPA.  
RAD-18~50QPB.

PRICE:

## WIRED REMOTE CONTROL

SPX-WKT2

**CHARACTERISTICS:**

- Wall mounting.
- Weekly program.
- Away from home.
- Multifunction: modes, temperatures, ventilation, night mode.
- Management of up to 13 indoor units.
- With choice of temperature sensor location.

**SPX-WKT2** COMPATIBLE WITH:  
RAK-18~35PSC.  
RAK-25~50RXB.  
RAK-18QXB.  
RAK-18~50RPC.  
RAK-15QPC.  
RAF-25~50RXB.  
RAI-25~50QPB.  
RAD-18~50QPB.

PRICE:

## WIRED REMOTE CONTROL

SPX-RCDB

**CHARACTERISTICS:**

- Wall mounting.
- 12 hour program.
- Away from home.
- Multifunction: modes, temperatures, ventilation, night mode.

**SPX-RCDB** COMPATIBLE WITH:  
RAK-60~70PPA.  
RAF-25~50RPA.  
RAI-25~50RPA.

PRICE:

## WI-FI ADAPTER

SPX-WFG01

**CHARACTERISTICS:**

- Wi-Fi adapter for Hi-Kumo application.
- Connect the air conditioning with the Hi-Kumo mobile app.

**SPX-WFG01** COMPATIBLE WITH:  
RAK-18~35PSC  
RAK-25~50RXB  
RAK-18QXB  
RAK-18~50RPC  
RAK-15QPC  
RAF-25~50RXB  
RAI-25~50QPB  
RAD-18~50QPB

PRICE:

## H-LINK BOX

PSC-6RAD



**CHARACTERISTICS:**

- Connects the indoor units of the residential range to an H-Link network.

**PSC-6RAD COMPATIBLE WITH:**  
The entire Residential range.

**PRICE:**

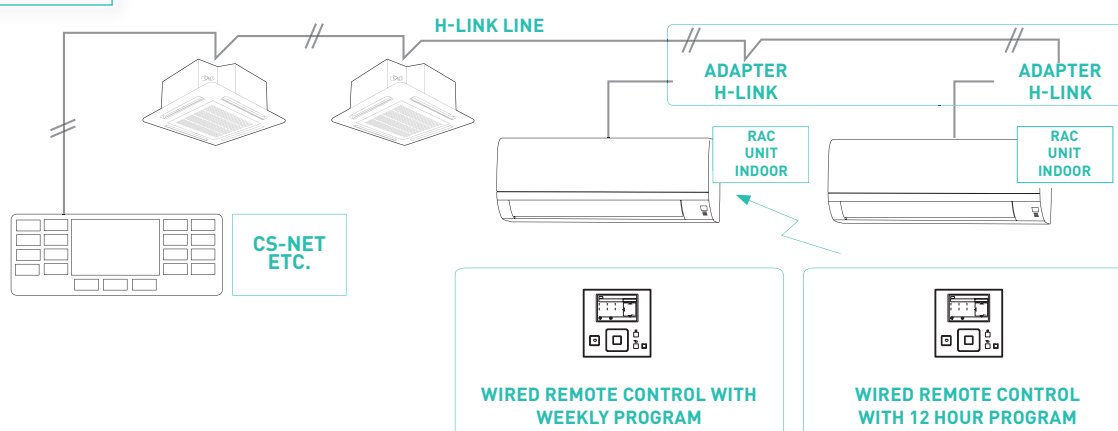

## FILTERS AND PRE-FILTERS

### ACTIVE CARBON-BASE SPECIAL AC FILTER

SPX-CFH25 / SPX-NTW3 / SPX-NTW4

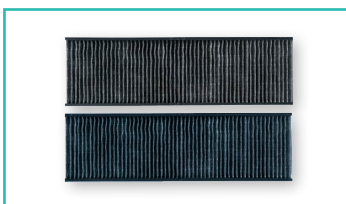

**CHARACTERISTICS:**

**Sustainable**

Won't leach due to organic solvents and has a long-lasting antimicrobial effect.

**Antimicrobial**

The growth of bacteria in a products surface is inhibited.

Effective across a wide scope, including germs, mold and yeast.

**Odor-elimination**

By inhibiting the growth of bacteria, it also inhibits the gases generated by the metabolisms of bacteria, thus is anticipated to have a deodorizing effect.

Effective on a wide range of odiferous elements

**Antiviral**

it has the ability to inactive viruses and therefore keep the surface of products hygienic.

**SPX-CFH25 COMPATIBLE WITH:**

RAK-15QPC  
RAK-18-50RPC  
RAK-18QXB  
RAK-25-50RXB  
RAF-RPA  
RAF-25-50RXB  
RAK-PEC  
RAK-PSC  
RAK-PSPA

**PRICE:**

**SPX-NTW3 COMPATIBLE WITH:**

RAK-60PPA  
RAI-RPA  
RAI-QPB

**PRICE:**

**SPX-NTW4 COMPATIBLE WITH:**

RAK-70PPA

**PRICE:**

### NANO TITANIUM FILTER

SPX-CFH15

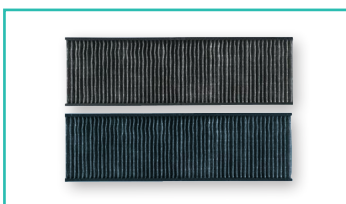

**CHARACTERISTICS:**

- Destroys particles less than one millionth of a millimeter (dust, pollen, bacteria and odors) using catalysis.

- 2 functions: deodorizing filter and elimination of bacteria.

**SPX-CFH15 COMPATIBLE WITH:**

RAF-25-50RXB.  
RAF-25-50RPA.

**PRICE:**

Note:  
The prices for accessories and controls indicated at this fee are applicable exclusively to orders that include machines.  
The separate purchase of these accessories and controls will be governed by the corresponding replacement parts fee.

## CONTROLS AND ACCESSORIES

# HEATING

### YUTAKI RANGE COOLING KIT

ATW-CKS-01 / ATW-CKS-02 / ATW-CKS-03 / ATW-CKSC-01 / ATW-CKM-01



#### CHARACTERISTICS:

- Connector that allows for operating the Yutaki range in reversible mode (heat / cold).
- It has to be placed in the lower part.

**ATW-CKS-01** COMPATIBLE WITH:  
Yutaki S 2-3 HP.

**ATW-CKS-02** COMPATIBLE WITH:  
Yutaki S 4-6 HP.

**ATW-CKS-03** COMPATIBLE WITH:  
Yutaki S 6-10 HP.

**ATW-CKSC-01** COMPATIBLE WITH:  
Yutaki S Combi.

**ATW-CKM-01** COMPATIBLE WITH:  
Yutaki M.

PRICE:

PRICE:

PRICE:

PRICE:

PRICE:

## CONTROL ACCESSORIES

### WIRELESS CONTROL ON/OFF. (RECEIVER INCLUDED)

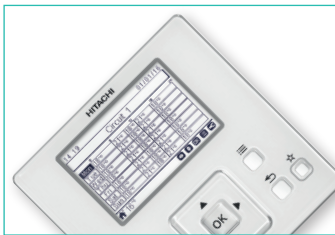

#### CHARACTERISTICS:

- Weekly program.
- Multifunction: modes, temperatures, ventilation.
- Eco Mode.
- Configuration and adjustment of the operating parameters.
- Several languages.

**PC-ARFHE** COMPATIBLE WITH:  
The entire Yutaki range.

PRICE:

### WIRELESS CONTROL ON/OFF. (RECEIVER INCLUDED)

ATW-RTU-04



#### CHARACTERISTICS:

- ON/OFF function.
- Easy to install.

**ATW-RTU-04** COMPATIBLE WITH:  
The entire Yutaki range.

PRICE:

### WIRELESS CONTROL. (RECEIVER INCLUDED)

ATW-RTU-05



#### CHARACTERISTICS:

- Multifunction.
- Easy to install.

**ATW-RTU-05** COMPATIBLE WITH:  
The entire Yutaki range.

PRICE:

#### Note:

The prices for accessories and controls indicated at this fee are applicable exclusively to orders that include machines. The separate purchase of these accessories and controls will be governed by the corresponding replacement parts fee.



## WIRELESS CONTROL FOR A SECOND CIRCUIT

ATW-RTU-06



- CHARACTERISTICS:**
- Multifunction.
  - Easy to install.
  - For controlling the temperature of a second circuit.

**ATW-RTU-06 COMPATIBLE WITH:**  
The entire Yutaki range.

**PRICE:**

## KNX INTERFACE

ATW-KNX02



- CHARACTERISTICS:**
- Centralizes control.
  - It allows for integrating the Yutaki range with domestic systems and allows handling multiple Yutakis.
  - 4 modes of operation and 6 groups of variables to control.

**ATW-KNX02 COMPATIBLE WITH:**  
The entire Yutaki range.

**PRICE:**

## AUXILIARY OUTPUT SIGNAL BOX

ATW-AOS-02

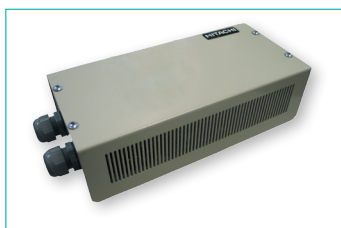

**COMPATIBLE WITH:**  
The entire Yutaki range.

**PRICE:**

## MODBUS FOR YUTAKI

ATW-MBS-02



**ATW-MBS-02 COMPATIBLE WITH:**  
The entire Yutaki range.

**PRICE:**

## TEMPERATURE ACCESSORIES

### TEMPERATURE SENSOR (2ND OUTDOOR TEMPERATURE SENSOR)

ATW-20S-02



**ATW-20S-02 COMPATIBLE WITH:**  
The entire Yutaki range.

**PRICE:**

### WIRED TEMPERATURE SENSOR

ATW-ITS-01



**ATW-ITS-01 COMPATIBLE WITH:**  
The entire Yutaki range.

**PRICE:**



**ATW-WTS-02Y COMPATIBLE WITH:**  
The entire Yutaki range.

**PRICE:**

Note:  
The prices for accessories and controls indicated at this fee are applicable exclusively to orders that include machines. The separate purchase of these accessories and controls will be governed by the corresponding replacement parts fee.

## CONTROLS AND ACCESSORIES

## HEATING

## ACCESSORIES FOR THE WATER CIRCUIT

## SECOND TEMPERATURE KIT

ATW-2TK-04

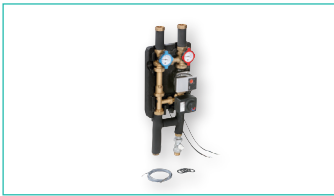

**ATW-2TK-04** COMPATIBLE WITH:  
The entire Yutaki range.

**PRICE:**

## SECOND TEMPERATURE KIT

ATW-2TK-03



**ATW-2TK-03** COMPATIBLE WITH:  
Yutaki S Combi with 200L DHW tank.

**PRICE:**

## HYDRAULIC SEPARATOR

ATW-HSK-01

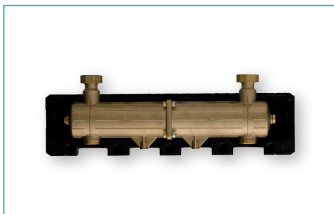

**CHARACTERISTICS:**

- Non-corrosive (brass).
- 4 ways of connection.
- With insulation.

**ATW-HSK** COMPATIBLE WITH:  
The entire Yutaki range.

**PRICE:**

## SAFETY AQUASTAT

ATW-AQT-01

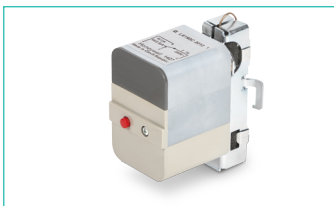

**CHARACTERISTICS:**

- Necessary for applications with radiant floor heating.

**ATW-AQT-01** COMPATIBLE WITH:  
The entire Yutaki range.

**PRICE:**

## 3-WAY VALVE

ATW-3WV-01

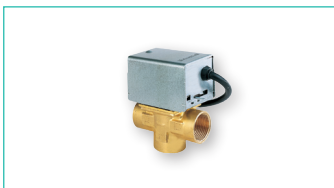

**CHARACTERISTICS:**

- Alternative operation DHW / Air conditioning.

**ATW-3WV-01** COMPATIBLE WITH:  
The entire Yutaki range.

**PRICE:**

## PROPORTIONAL DISCHARGE VALVE FOR VARIABLE FLOW INSTALLATIONS

ATW-DPOV-01



**CHARACTERISTICS:**

- Necessary for applications with radiant floor heating.

**ATW-DPOV-01** COMPATIBLE WITH:  
The entire Yutaki range.

**PRICE:**

Note:

The prices for accessories and controls indicated at this fee are applicable exclusively to orders that include machines. The separate purchase of these accessories and controls will be governed by the corresponding replacement parts fee.

## ELECTRIC RESISTANCE

### WEH-6E



**CHARACTERISTICS:**

- 6 kW mono/triphas
- 3 stages of 2 kW
- Integrated power relay.
- Steel body with external insulation.

**WEH-6E COMPATIBLE WITH:**

The entire Yutaki range.

**PRICE:**

## DOMESTIC HOT WATER TANK

### DHW TANK

#### DHWT-200S-3.0H2ES / DHWT-300S-3.0H2E



**CHARACTERISTICS:**

- 6 kW mono/triphas
- 3 stages of 2 kW
- Integrated power relay.
- Steel body with external insulation.

**DHWT-200S-3.0H2ES COMPATIBLE WITH:**

Yutaki S, Yutaki S80, Yutaki M

**PRICE:**

**DHWT-300S-3.0H2E COMPATIBLE WITH:**

Yutaki S, Yutaki S80, Yutaki M

**PRICE:**

MODEL			DHWT200S-3.0H2Ew	DHWT300S-3.0H2E
Water accumulator	Volume	Liters	19	300
	Material		Enameled (DIN 4753)	
	Maximum temperature	°C	75	75
	Maximum pressure	bar	10	10
Water heat exchanger	Temp. Max. Coil	°C	99	99
	Max. coil pressure	bar	10	10
	Exchanger surface	m <sup>2</sup>	0.8	0.8
Type of isolation	Polyurethane	mm	50	50
Auxiliary resistance	Power	kW	3	3
Hydraulic connection	In DHW	Centi-meters	1.91 (f)	1.91 (f)
	Out DHW		1.91 (f)	1.91 (f)
	DHW recirculation		1.91 (f)	1.91 (f)
	In water coil		1.91 (f)	1.91 (f)
	Out water coil		1.91 (f)	1.91 (f)
Accessories	Thermometer		YES	
	Safety thermostat		YES	

Note:  
The prices for accessories and controls indicated at this fee are applicable exclusively to orders that include machines.  
The separate purchase of these accessories and controls will be governed by the corresponding replacement parts fee.



## CONTROLS AND ACCESSORIES

# COMMERCIAL AND VRF

## INDIVIDUAL CONTROLS

### WIRED MULTIFUNCTION CONTROL

#### PC-ARFPE



#### CHARACTERISTICS:

- Weekly program.
- Configuration and adjustment of the operating parameters.
- Multifunction. Remote program of ON/OFF options, error reporting, automatic route setting.
- Control of 1 to 16 indoor units.
- Self-diagnosis, anti-freezing and temperature reduction.
- Integrated environment probe.
- Several languages.
- LCD Screen.
- User friendly.

#### PC-ARFPE COMPATIBLE WITH:

Range of System Free indoor units.  
Commercial Range (Utopia).  
VRF Set Free Range.

#### PRICE:

### SIMPLIFIED WIRED CONTROL

#### PC-ARH



#### CHARACTERISTICS:

- Control of 1 to 16 indoor units (in master and slave)
- Ideal for hotels.
- Size
- Simplified functions: ON/OFF, Mode, temperature, ventilation.
- Preference function with centralized control or CS-NET Web.

#### PC-ARH COMPATIBLE WITH:

Range of System Free indoor units.  
Commercial Range (Utopia).  
VRF Set Free Range.

#### PRICE:

### INDIVIDUAL CONTROL

#### PC-AWR



#### CHARACTERISTICS:

- Wireless remote control
- Receiver kit has to be installed in IU
- Operation mode
- Automatic cooling/heating operation
- Simple timer
  - On time
  - Off time
- Infrared signal change (A/B)

#### PC-AWR COMPATIBLE WITH:

All system free indoor units

#### PRICE:

#### Note:

The prices for accessories and controls indicated at this fee are applicable exclusively to orders that include machines. The separate purchase of these accessories and controls will be governed by the corresponding replacement parts fee.

## INFRARED RECEIVER

PC-ALHC / PC-ALHD / PC-ALH3 / PC-ALHP1



**CHARACTERISTICS:**

- Receiver for indoor cassette units.
- It is placed in the corner of the panel.

**PC-ALHC** COMPATIBLE WITH:  
RCIM-FSN4E.

PRICE:

**PC-ALHD** COMPATIBLE WITH:  
RCD-FSN3.

PRICE:

**PC-ALH3** COMPATIBLE WITH:  
RCI-FSN4.

PRICE:

**CHARACTERISTICS:**

- Receiver for indoor Ceiling type units.
- It is placed in the corner of the panel.

**PC-ALHP1** COMPATIBLE WITH:  
RPC-FSN3.

PRICE:

## INFRARED RECEIVER FOR WALL-MOUNTED UNITS

PC-ALHZ / PC-ALHZF



**CHARACTERISTICS:**

- Infrared receiver for wireless remote control.

**PC-ALHZ** COMPATIBLE WITH:  
RCIM-FSN3E.  
RCD-FSN3.  
RPC-FSN3.  
RPI-FSN(3/4)(P)E.  
RPIM-FSN4E(-DU).  
RPK-FSN(H)2M.  
RPF(I)-FSN2E.

PRICE:

**PC-ALHZF** COMPATIBLE WITH:  
RCI-FSN4.  
RPK-FSN(H)3M.

PRICE:

## REMOTE TEMPERATURE SENSOR

THM-R2AE

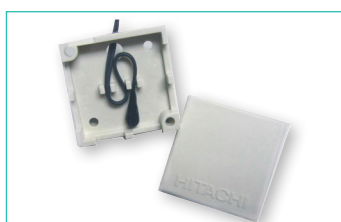

**CHARACTERISTICS:**

- Equipped with a diverted probe, it will be regulated in relation to the ambient temperature.

**THM-R2AE** COMPATIBLE WITH:  
Range of System Free indoor units.  
Commercial Range (Utopia).

PRICE:

Note:  
The prices for accessories and controls indicated at this fee are applicable exclusively to orders that include machines.  
The separate purchase of these accessories and controls will be governed by the corresponding replacement parts fee.

## CENTRALIZED CONTROLS

### CENTRALIZED CONTROL

#### PSC-A64S



#### CHARACTERISTICS:

- Control of up to 256 indoor units (16 groups).
- Operates with or without remote control.
- H-Link management.
- Automatic setting
- Adjusts the airflow and automatic deflector.
- Alarm code on the screen.
- The central station can be used in conjunction with the individual remote controls of each unit.

#### PSC-A64S COMPATIBLE WITH:

Range of indoor units System Free.  
Commercial Range (Utopia).  
VRF Set Free Range.

#### PRICE:

### WEEKLY PROGRAMMER

#### PSC-A1T



#### CHARACTERISTICS:

- Programmable weekly timer, for those remote controls that do not have weekly program.
- Allows 3 on/off switches per day.
- Creation of programs.
- Compatible with PC-ARFPE, PSC-A64S, PC-ARH.
- Individual control of indoor units or groups.

#### PSC-A1T COMPATIBLE WITH:

Range of System Free indoor units.  
Commercial Range (Utopia).  
VRF Set Free Range.

#### PRICE:

### CENTRALIZED ON/OFF CONTROL

#### PSC-A16RS



#### CHARACTERISTICS:

- Manages the ON/OFF for 16 groups.
- Up to 8 centralized ON/OFF controllers (PSC-A16RS) can be connected to an H-LINK.
- Two switches for the ON/OFF function: single or simultaneous (up to 16 groups of units at the same time).
- Automatic parameterization according to the capacity of the units.

#### PSC-A16RS COMPATIBLE WITH:

Range of System Free indoor units.  
Commercial Range (Utopia).  
VRF Set Free Range.

#### PRICE:

### COMMERCIAL CONTROL-VRF

#### PSC-A32MN



#### CHARACTERISTICS:

- Connection to the H-LINK system and used for central control and supervision.
- Supervision of the operating conditions by blocks / groups.
- Programmed operation for block / groups (run / stop and temperature setting).
- Control to limit the capacity of the outdoor units to give a percentage, at certain times of the day, by adjusting the external input.
- Indication and calculation of the accumulated running time for each group.

#### PSC-A32MN COMPATIBLE WITH:

Range of System Free indoor units.  
Commercial Range (Utopia).  
VRF Set Free Range.

#### PRICE:



## TOUCH SCREEN. CENTRALIZED SYSTEM

### PSC-A64GT



#### CHARACTERISTICS:

- Connection to the H-LINK system and used for central control and supervision.
- Supervision of the operating conditions by blocks/groups.
- Up to 4 blocks with 16 groups (64 groups).
- Up to 8 central stations connected to H-LINK.
- Configuration and adjustment of the operating parameters.
- Weekly and vacation program.
- Self-diagnosis, anti-freezing and temperature reduction.

#### PSC-A64GT COMPATIBLE WITH:

Range of System Free indoor units.  
Commercial Range (Utopia).  
VRF Set Free Range.

#### PRICE:

## CS-NET WEB. INTEGRAL MANAGEMENT

### PSC-A160WEB1



#### CHARACTERISTICS:

- Centralized control interface.
- It can handle up to 160 indoor units and 64 outdoor units.
- It connects to local area network or internet via an Ethernet port and remote parameters can be set and monitored.
- Accessible from any computer that is connected to the same network.
- Standard consumption control.

#### PSC-160WEB1 COMPATIBLE WITH:

Range of System Free indoor units.  
Commercial Range (Utopia).  
VRF Set Free Range.

#### PRICE:

## CS-NET WEB 64. INTEGRAL MANAGEMENT

### HC-A64NET

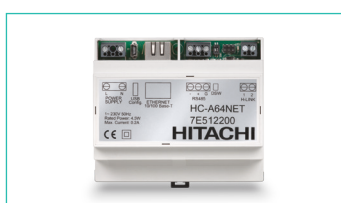

#### CHARACTERISTICS:

- H-LINK gateway that links the units through the H-LINK protocol.
- Up to 64 indoor units can be connected.
- Up to 8 CS-NET WEB 64 can be connected to the same CS NET Manager.
- Easy installation.

#### HC-A64NET COMPATIBLE WITH:

Range of System Free indoor units.  
Commercial Range (Utopia).  
VRF Set Free Range.

#### PRICE:

## CS-NET WEB LT/XT MANAGER

### CS NET WEB MANAGER

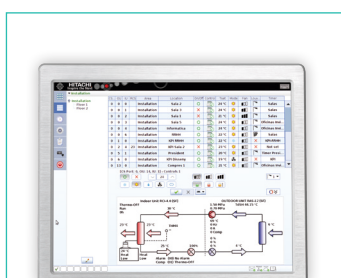

#### CHARACTERISTICS:

- Centralized independent control with touch screen connected to the HC-A64NET gateway.
- Controls up to 1280 units.
- Connected to H-LINK, controlling up to 160 indoor units.
- Stores historical data, manages time and energy consumption.
- Timer with unlimited calendar settings.
- Night mode of the outdoor unit.

#### CS-NET WEB LT MANAGER (10")

COMPATIBLE WITH:  
Range of System Free indoor units.  
Commercial Range (Utopia).

#### CS-NET WEB MANAGER XT (43.18 CM)

COMPATIBLE WITH:  
Range of System Free indoor units.  
Commercial Range (Utopia).

#### PRICE:

#### PRICE:

#### Note:

The prices for accessories and controls indicated at this fee are applicable exclusively to orders that include machines. The separate purchase of these accessories and controls will be governed by the corresponding replacement parts fee.

## CONTROLS AND ACCESSORIES

### DRAINPIPE CONNECTION KIT

**DBS26**



**CHARACTERISTICS:**

- 32 mm drainage.
- One kit per module.

**DBS26 COMPATIBLE WITH:**

- AS - 3HVNP.
- RAS-4~6H(V)N(P/C)E.
- RAS 8~10H(V)N(P/C)E
- 12HN(P/C)

**PRICE:**

### DRAINPIPE CONNECTION KIT FOR SET FREE FSXN1E AND FSXNH(.E)

**DBS-TP10A**



**CHARACTERISTICS:**

- One kit must be ordered for each outdoor unit module.

**DBS-TP10A COMPATIBLE WITH:**

- Set Free FSXN1E and FSXNH(.E)

**PRICE:**

### CASSETTE TRACK SHUTTER

**PI-23LS5**



**PI-23LS5 COMPATIBLE WITH:**

- Cassette RCI.

**PRICE:**

### DRAINPIPE CONNECTION KIT FOR IVX

**DBS 12L**



**CHARACTERISTICS:**

- 15 mm drainage.

**DBS 12L COMPATIBLE WITH:**

- RAS - 2~2.5 HVNP.
- RAS - 3HVNC.

**PRICE:**

### T DUCT CONNECTION KIT

**TKCI-232**



**TKCI-232 COMPATIBLE WITH:**

- RCI.

**PRICE:**

### FRESH AIR ENTRANCE KIT

**PD-75**



**PD-75 COMPATIBLE WITH:**

- RCI.

**PRICE:**

Note:

The prices for accessories and controls indicated at this fee are applicable exclusively to orders that include machines. The separate purchase of these accessories and controls will be governed by the corresponding replacement parts fee.

## HI TOOLKIT, PROJECT MANAGEMENT SOFTWARE



**HITACHI makes a valuable tool available for free to professionals that greatly facilitates the entire management of projects, automatically generating the information needed for each job. It stands out because of the complete information contained on the entire HITACHI range of products.**

### Who is it for?

Construction designers, engineering departments, installers, technical services, architects...

### Where do you update it?

Free for professionals.

### How?

Exclusive HITACHI software. A complete project with just one click.

### How much does it cost?

Free for professionals.

### What for?

To quickly select the appropriate HITACHI air conditioning system without errors.

### Where can I get it?

Through your commercial HITACHI contact.



### PRODUCT SELECTION

-The entire range of HITACHI MonoMultizone, IVX, ES, Centrifuge, 8 HP-54 HP 2 pipes / 3 pipes SET FREE, FSXN and FSXNH "high COP" of 5~36 HP.

### COOLING SCHEME

-Ability to recover the structure of an existing cooling diagram in the project to create a variant.  
-Printing on A4 with positionable cutting lines or on A3

### ELECTRIC SCHEME

-Electrical power supply.  
-Communication port.  
-Control and accessories systems.  
-New technical documents.  
-Comment areas.

### DESCRIPTION OF THE SOLUTION

-Schemes that are automatically generated by Hi-Toolkit according to the technologies of the selected outdoor units: ranges of Set FREE, UTOPIA, MonoMultizone, PERFORMANCE.

### QUANTITATIVE

-Selected HITACHI systems.  
- Required pipes and electrical materials.  
-Refrigerant.

### REPAIRS

-Regulations made in situ.  
-List of controls.  
-Repair report.



# CS-NET WEB

The CS-NET WEB is a centralized control interface that allows for remote control and monitoring of an installation, thus improving the operating costs of buildings subject to the use of heating and air conditioning.

## FUNCTIONALITIES

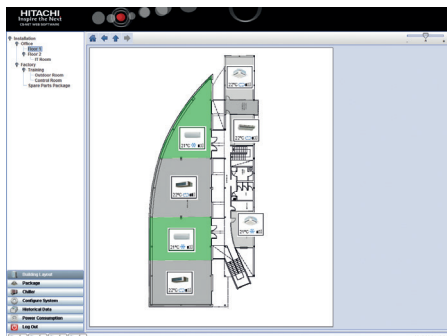

Date	Port	OE	UE	Code	Description de l'alarme	Libre
15.2.2007 1.13	4	0	43	0022	Membre de communication. L'unité intérieure n'a jamais été	Full
15.2.2007 1.13	4	1	63	0021	Membre de communication. L'unité intérieure n'a jamais été	Full
15.2.2007 1.13	4	2	63	0020	Membre de communication. L'unité intérieure n'a jamais été	Full
15.2.2007 1.14	0	0	42	0022	Membre de communication. Le groupe extérieur n'a jamais été	Group exterieur
15.2.2007 1.14	0	1	42	0021	Membre de communication. Le groupe extérieur n'a jamais été	Group exterieur
15.2.2007 1.14	0	2	42	0020	Membre de communication. Le groupe extérieur n'a jamais été	Group exterieur
15.2.2007 1.14	0	4	42	0022	Membre de communication. Le groupe extérieur n'a jamais été	Bureau vide
15.2.2007 1.14	0	4	42	0021	Membre de communication. Le groupe extérieur n'a jamais été	Bureau
15.2.2007 1.14	0	5	42	0022	Membre de communication. Le groupe extérieur n'a jamais été	Bureau VC
15.2.2007 1.14	0	6	42	0021	Membre de communication. Le groupe extérieur n'a jamais été	Bureau
15.2.2007 1.14	0	7	42	0022	Membre de communication. Le groupe extérieur n'a jamais été	Bureau continueur
15.2.2007 1.14	0	8	42	0021	Membre de communication. Le groupe extérieur n'a jamais été	Bureau OE
15.2.2007 1.14	0	9	42	0022	Membre de communication. Le groupe extérieur n'a jamais été	Local serveur
15.2.2007 01.2	0	0	46	0019	Mission Augmentation de la haute pression.	Service bloqué
15.2.2007 01.2	0	0	46	0018	Mission Augmentation de la haute pression.	Call de rupture
15.2.2007 01.2	0	0	46	0017	Mission Augmentation de la haute pression.	Bureau vide
15.2.2007 01.2	0	0	46	0016	Mission Augmentation de la haute pression.	Bureau OE
15.2.2007 01.2	0	0	46	0015	Mission Augmentation de la haute pression.	Local serveur
15.2.2007 01.2	0	0	46	0014	Mission Augmentation de la haute pression.	Call de rupture
15.2.2007 01.2	0	0	46	0013	Mission Augmentation de la haute pression.	Bureau vide
15.2.2007 01.2	0	0	46	0012	Mission Augmentation de la haute pression.	Bureau OE
15.2.2007 01.2	0	0	46	0011	Mission Augmentation de la haute pression.	Local serveur

## DISTRIBUTION OF ENERGY CONSUMPTION

This function, available on a standard form, enables the energy consumptions of all or part of the indoor units managed by the CS-NET WEB to be proportionally distributed over a period of time. This distribution is set in percentages. For the distribution in kWh, counters should be placed on the outdoor units (Not supplied). New touch screens.

### CS NET LT/XT MANAGER (25.4 cm/43.18 cm)

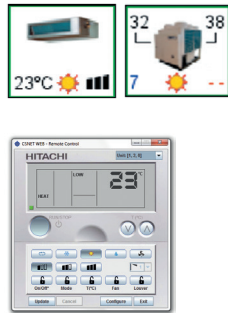

- CS-NET WEB v3.3 offers a new means for controlling your system called "Building scheme". It is very easy to use. All units are set in a building implementation plan.
- CS-NET WEB v3.3 also has a virtual remote control that you can open by clicking on the icon of a unit or that you can use simply by installing it on your PC\*.
- The virtual remote control has the basic functionalities of the standard remote control. It is provided as standard.
- \* PC is connected to the same Ethernet network as CS-NET WEB.

## AN AUTHENTIC MAINTENANCE TOOL

- From the client interface, the user pilots the installation and can visualize any dysfunction that may occur in the installation: error code, description of the verified problem.
- Alarm Bulletin: From the appearance of the first error, the CS-NET WEB automatically generates an alarm bulletin which can be exported at any time (SYSTEM FREE range).
- Historical data: CS-NET WEB registers all the operating parameters of the installation and allows the user to trace the evolution of the retained parameters in a defined time interval in order to accurately analyze the operations and to issue precise intervention reports.
- A mail server allows you to receive an e-mail alert in the event that an error code appears in the installation. It can be controlled using the Modbus/IP protocol.

Date	Port	OE	UE	Code	Description de l'alarme	Libre
15.2.2007 1.13	4	0	43	0022	Membre de communication. L'unité intérieure n'a jamais été	Full
15.2.2007 1.13	4	1	63	0021	Membre de communication. L'unité intérieure n'a jamais été	Full
15.2.2007 1.13	4	2	63	0020	Membre de communication. L'unité intérieure n'a jamais été	Full
15.2.2007 1.14	0	0	42	0022	Membre de communication. Le groupe extérieur n'a jamais été	Group exterieur
15.2.2007 1.14	0	1	42	0021	Membre de communication. Le groupe extérieur n'a jamais été	Group exterieur
15.2.2007 1.14	0	2	42	0020	Membre de communication. Le groupe extérieur n'a jamais été	Group exterieur
15.2.2007 1.14	0	4	42	0022	Membre de communication. Le groupe extérieur n'a jamais été	Bureau vide
15.2.2007 1.14	0	4	42	0021	Membre de communication. Le groupe extérieur n'a jamais été	Bureau
15.2.2007 1.14	0	5	42	0022	Membre de communication. Le groupe extérieur n'a jamais été	Bureau VC
15.2.2007 1.14	0	6	42	0021	Membre de communication. Le groupe extérieur n'a jamais été	Bureau
15.2.2007 1.14	0	7	42	0022	Membre de communication. Le groupe extérieur n'a jamais été	Bureau continueur
15.2.2007 1.14	0	8	42	0021	Membre de communication. Le groupe extérieur n'a jamais été	Bureau OE
15.2.2007 1.14	0	9	42	0022	Membre de communication. Le groupe extérieur n'a jamais été	Local serveur
15.2.2007 01.2	0	0	46	0019	Mission Augmentation de la haute pression.	Service bloqué
15.2.2007 01.2	0	0	46	0018	Mission Augmentation de la haute pression.	Call de rupture
15.2.2007 01.2	0	0	46	0017	Mission Augmentation de la haute pression.	Bureau vide
15.2.2007 01.2	0	0	46	0016	Mission Augmentation de la haute pression.	Bureau OE
15.2.2007 01.2	0	0	46	0015	Mission Augmentation de la haute pression.	Local serveur
15.2.2007 01.2	0	0	46	0014	Mission Augmentation de la haute pression.	Call de rupture
15.2.2007 01.2	0	0	46	0013	Mission Augmentation de la haute pression.	Bureau vide
15.2.2007 01.2	0	0	46	0012	Mission Augmentation de la haute pression.	Bureau OE
15.2.2007 01.2	0	0	46	0011	Mission Augmentation de la haute pression.	Local serveur

## INSTALLATION

This interface is particularly suitable for building managers who are responsible for the operation and management of an air conditioning system that includes equipment from our Set Free, Utopia and/or Samurai series. Regardless of the surface and the nature of the treated sites, CS-NET WEB offers maintenance companies all the advantages of a simplified Centralized Technical Management solution.

- The CS-NET WEB is a "material" interface associated with a "computer" interface that operates autonomously: the PC is only necessary for commissioning and periodic supervision.
- The on-site switchboard can be connected to both an local area network (LAN) and an ADSL-type internet modem.
- Standard distance: 1000 m\*.
- Increased limits: 128 indoor units (CS NET 160) and 64 outdoor units (HLINK 2) can be controlled in the (system Free) range.
- System Free with an interface or 32 Samurai (8 per electrical panel).
- Built-in Modbus TCP port as standard (CS NET 160 only).

## SET FREE AND UTOPIA RANGE

### Control functions

- Start/stop.
- Operating mode.
- Setpoint temperature.
- Accessible setpoint range.
- Ventilation speed.
- Air flow direction.
- Local/central mode.

### Control functions

- Status: start/stop.
- Operating mode.
- Setpoint temperature.
- Ambient recovery temperature.
- Filter.
- Ventilation speed.
- Air flow direction.
- Alarm.
- Error code.
- Clock.

## SAMURAI RANGE

### Control functions

- Start/stop.
- Operating mode.

### Control functions

- Status: start/stop.
- Operating mode.
- Room temperature.
- Return water temperature.
- Water flow temperature.
- Liquid temperature.
- Evaporation temperature.
- Condensation temperature.
- Suction temperature.
- High pressure.
- Low pressure.
- Alarm.
- Error code.
- Clock.

## SIMPLICITY OF PARAMETERS

From the customer interface, the user selects all the operating parameters of an indoor unit. These parameters can be applied very quickly to all or part of the units of the place (SYSTEM FREE Range). In order to limit access to the settings, it is possible to block a certain number of parameters (setpoint temperature, operating mode, ventilation speed, start/stop) or limit the available setting ranges (SYSTEM FREE Range).

## LIMITED AND PROTECTED ACCESS

There are numerous levels of password-protected access, which limit access to the settings of the operating parameters.

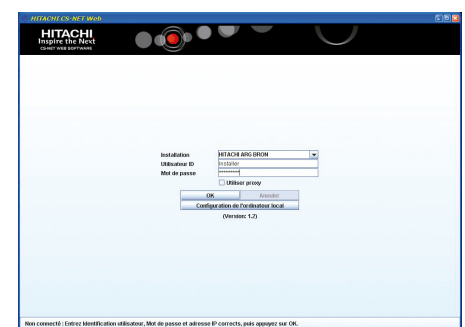
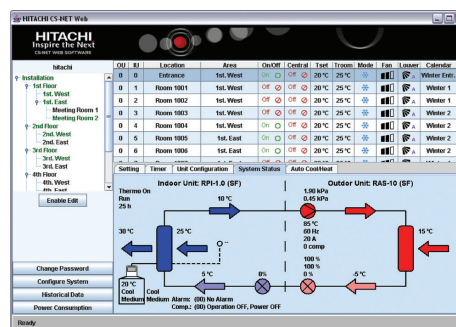

Recommendation: Provide an internet connection in the place where the CS-NET WEB "material" interface for remote access is received.

## LONG-TERM PROGRAMMER

The clock can be programmed for 4 years, thereby allowing for long-term autonomous operation. In order to simplify program, numerous templates can be created that can be applied to one, several or all the units in the place.

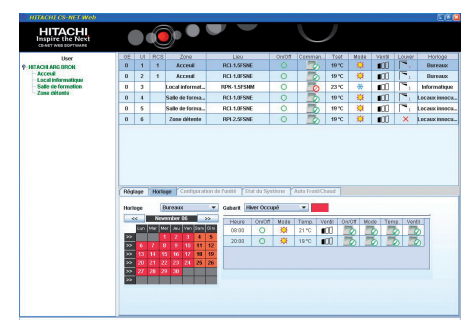

## MODBUS PROTOCOL

Most building supervision systems use a Modbus connection. The Modbus protocol is a serial dialog protocol based on a hierarchical structure between a master unit and slave units. It is also standard in industrial applications.

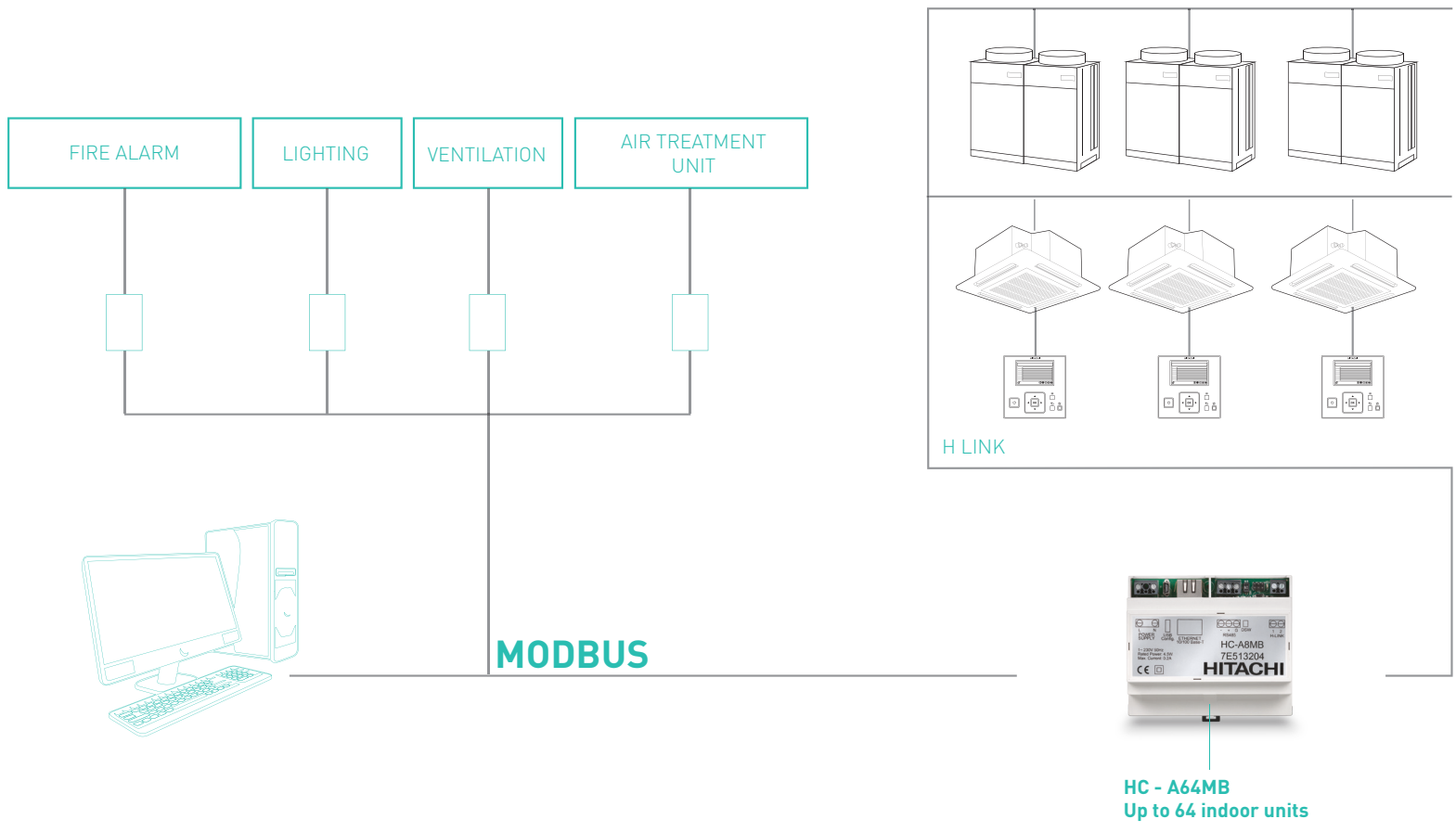
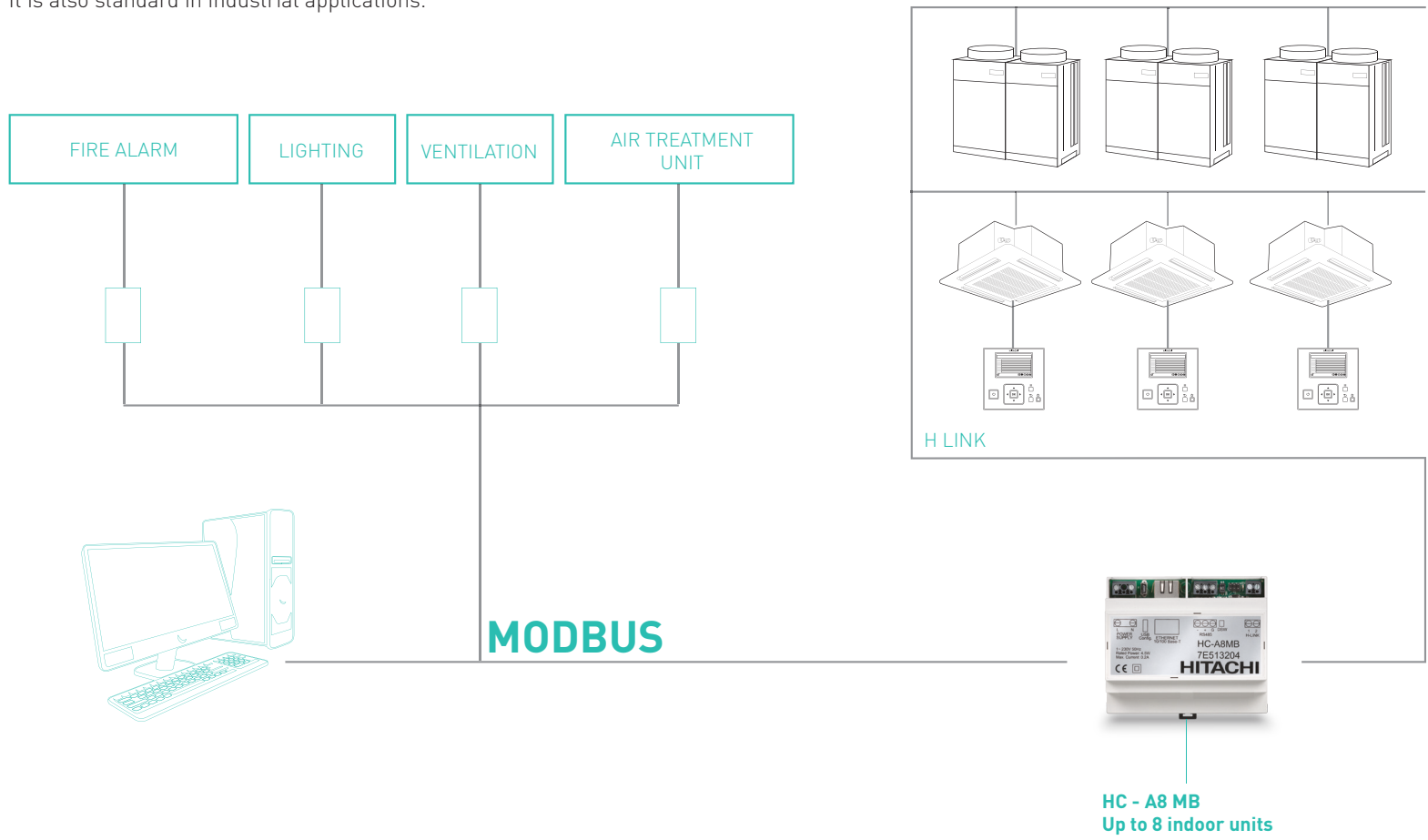



## KNX PROTOCOL

The KNX is a bus dedicated to the "Building", standardized and independent from the manufacturers (lighting, heating, security, energy management, measurement, etc.). Based on the standard bus EIB, EHS, Batibus, the KNX guarantees the interoperability of products bearing the KNX logo. It is an ISO standard.

Orientation: Large and medium buildings, home automation.

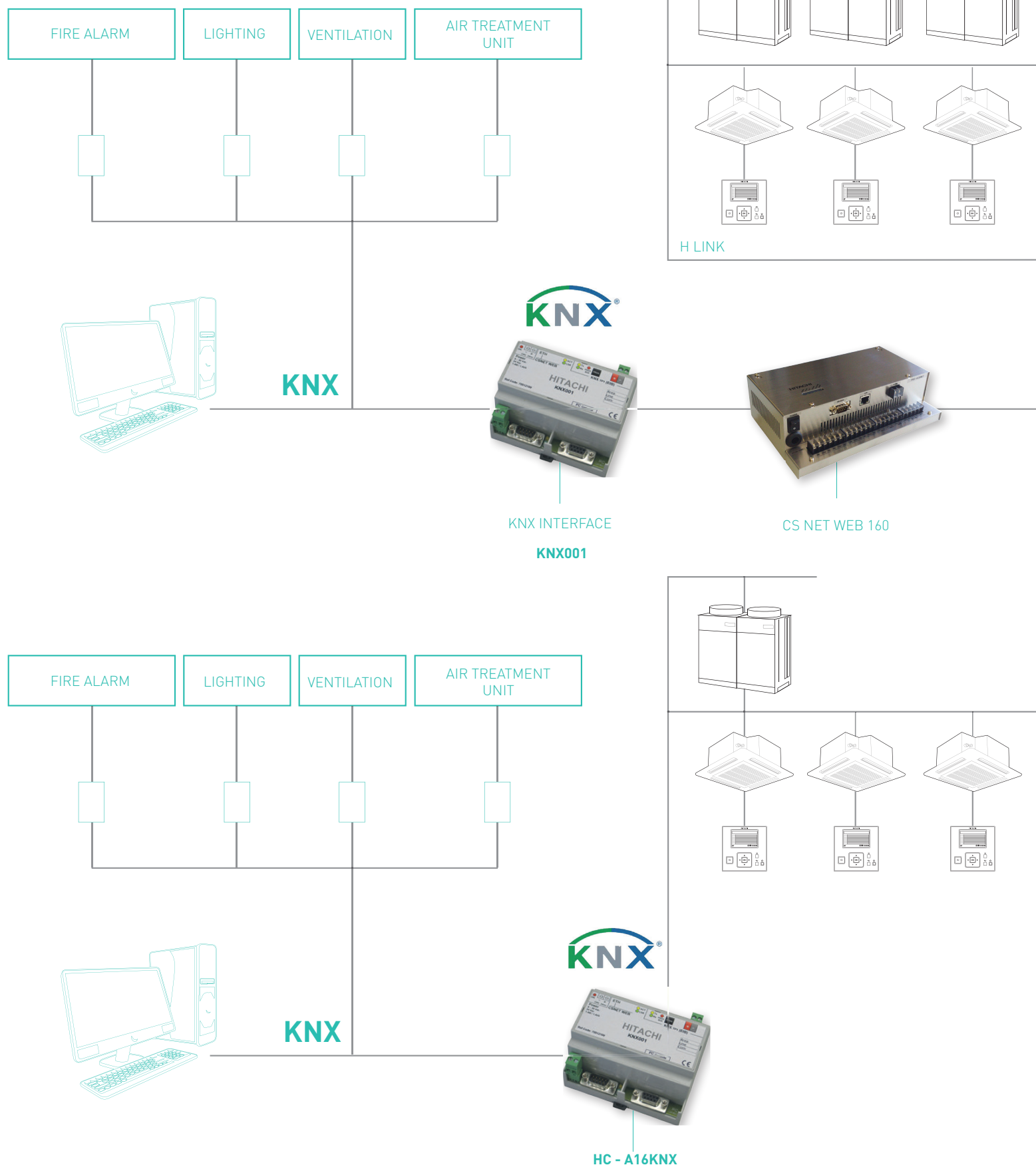

## HARC-I/O FOR MANAGING AND DIALOGUING WITH THIRD PARTIES

Most building supervision systems This interface allows the integration of the HITACHI centralized management system into both air treatment units and ventilation units external to the HITACHI system.

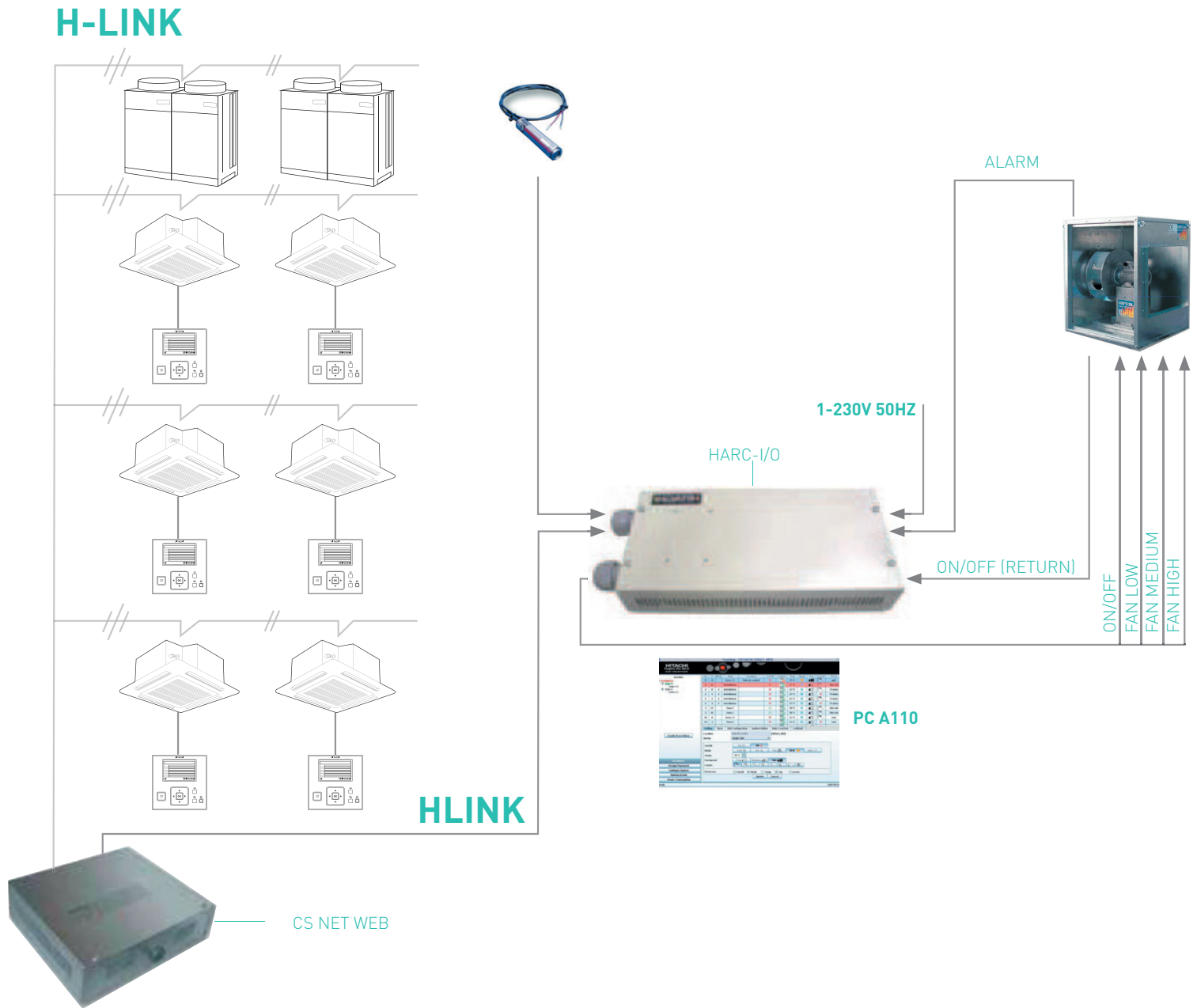

# H-LINK

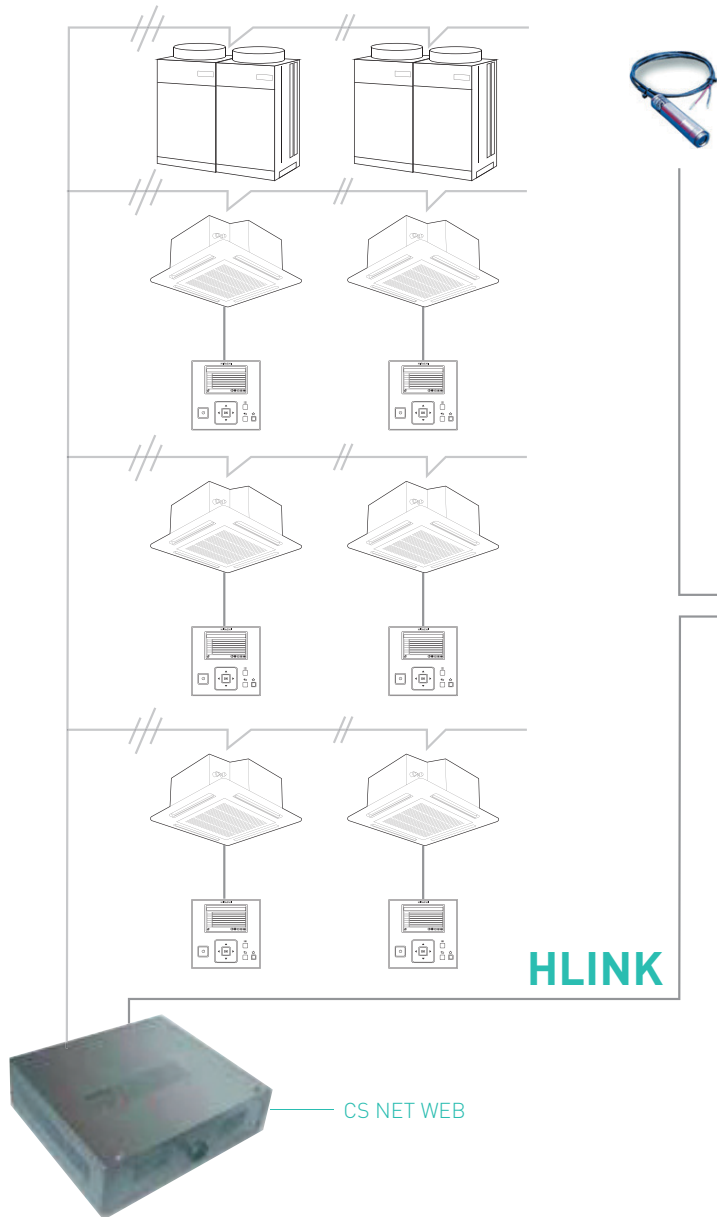

## TABLE OF CONTROLS

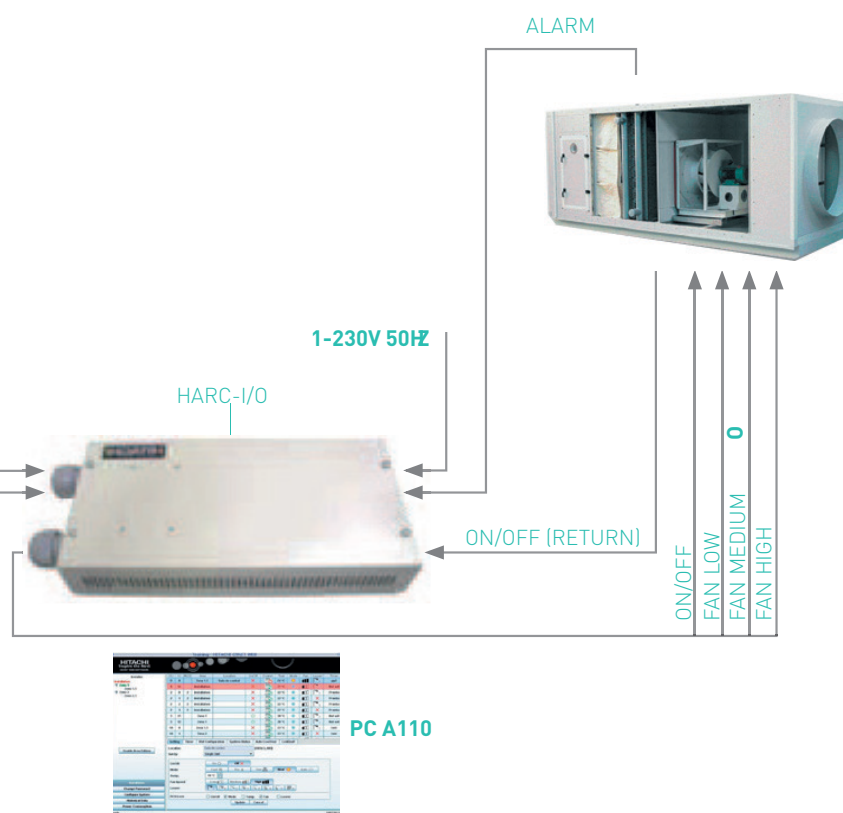















[www.johnsoncontrols.com](http://www.johnsoncontrols.com)



**Hitachi. Certified Quality**



The specifications of this catalog can be changed without prior notice to allow HITACHI to incorporate the latest innovations for its customers. The information contained in this catalog is merely informative. HITACHI declines any liability, in the broadest sense, for damage, whether direct or indirect, arising from the use and/or interpretation of the recommendations in this catalog.



**HITACHI**  
Air conditioning solutions